

JVC

SERVICE MANUAL

COLOR TELEVISION

BASIC CHASSIS

GF2

AV-N29301 AV-N34301

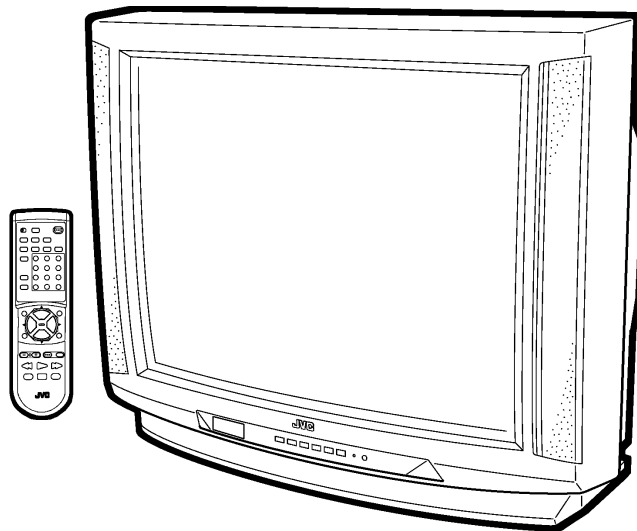

CONTENTS

■ SPECIFICATIONS	2
■ SAFETY PRECAUTIONS	3
■ FEATURES	4
★ INSTRUCCIONES DE OPERACIÓN (APPENDIX)	1-1
■ FUNCTIONS	5
■ SPECIFIC SERVICE INSTRUCTIONS	6
■ SERVICE ADJUSTMENTS	12
★ STANDARD CIRCUIT DIAGRAM (APPENDIX)	2-1
■ PARTS LIST	31

SPECIFICATIONS

Items	Contents	
	AV-N29301	AV-N34301
Dimensions (W x H x D)	29-5/8" x 23-1/4" x 19-1/2" 75.2cm x 59cm x 49.4cm	33-7/8" x 27" x 21-5/8" 85.9cm x 68.4cm x 54.8cm
Mass	35.5kg	52kg
TV System and Color system TV RF System Color System Sound System	CCIR(M) NTSC BTSC (Multi Channel Sound)	
TV Receiving Channels and Frequency VL Band VH Band UHF Band	(02~06) 54MHz~88MHz (07~13) 174MHz~216MHz (14~69) 470MHz~806MHz	
CATV Receiving Channels and Frequency Low Band High Band Mid Band Super Band Hyper Band Ultra Band Sub Mid Band TV/CATV Total Channel	(02~06) (07~13) (14~22) (23~36) (37~64) (65~94, 100~125) (01, 96~99) 180 Channels	(54MHz~804MHz)
Intermediate Frequency Video IF Carrier Sound IF Carrier	45.75 MHz 41.25 MHz (4.5MHz)	
Color Sub Carrier	3.58 MHz	
Power Input	120V AC, 60Hz	
Power Consumption	125W	135W
Picture Tube High Voltage	29" (74cm) measured diagonally, Full Square 29kV ± 1.3kV (at zero beam current)	34" (86cm) measured diagonally, Full Square 31kV ± 1.3kV (at zero beam current)
Speaker Audio Power Output	2" x 4-3/4" / 5 x 12cm Oblong type x 2 5W+5W	
Input (1 / 2) (Front input terminal is the bridge connection with Input 2 terminal)	Video : 1Vp-p 75 Ω (RCA pin jack) Audio : 500mVrms (-4dBs), High Impedance (RCA pin jack) S-Video Y : 1Vp-p positive (negative sync provided, when terminated with 75 Ω) C : 0.286Vp-p (burst signal, when terminated with 75 Ω)	
Audio Output (Variable / Fix : Selectable)	Variable : More then 0~1550mVrms (+6dBs) Low Impedance (400Hz when modulated 100%) (RCA pin jack) Fix : 500mVrms(-4dBs) Low Impedance (400Hz when modulated 100%) (RCA pin jack)	
AV Compu link EX Input	3.5mm mini jack	
Antenna terminal	75 Ω (VHF/UHF) Terminal, F-Type Connector	
Remote Control Unit	RM-C382-1A (AA/R6/UM-3 battery x 2)	

Design & specifications are subject to change without notice.

SAFETY PRECAUTIONS

- The design of this product contains special hardware, many circuits and components specially for safety purposes. For continued protection, no changes should be made to the original design unless authorized in writing by the manufacturer. Replacement parts must be identical to those used in the original circuits. Service should be performed by qualified personnel only.
- Alterations of the design or circuitry of the products should not be made. Any design alterations or additions will void the manufacturer's warranty and will further relieve the manufacturer of responsibility for personal injury or property damage resulting therefrom.
- Many electrical and mechanical parts in the products have special safety-related characteristics. These characteristics are often not evident from visual inspection nor can the protection afforded by them necessarily be obtained by using replacement components rated for higher voltage, wattage, etc. Replacement parts which have these special safety characteristics are identified in the parts list of Service manual. **Electrical components having such features are identified by shading on the schematics and by (Δ) on the parts list in Service manual.** The use of a substitute replacement which does not have the same safety characteristics as the recommended replacement part shown in the parts list of Service manual may cause shock, fire, or other hazards.
- Use isolation transformer when hot chassis.**
The chassis and any sub-chassis contained in some products are connected to one side of the AC power line. An isolation transformer of adequate capacity should be inserted between the product and the AC power supply point while performing any service on some products when the HOT chassis is exposed.
- Don't short between the LIVE side ground and ISOLATED (NEUTRAL) side ground or EARTH side ground when repairing.**
Some model's power circuit is partly different in the GND. The difference of the GND is shown by the LIVE : (⊥) side GND, the ISOLATED(NEUTRAL) : (⊕) side GND and EARTH : (⊕) side GND. Don't short between the LIVE side GND and ISOLATED(NEUTRAL) side GND or EARTH side GND and never measure with a measuring apparatus (oscilloscope etc.) the LIVE side GND and ISOLATED(NEUTRAL) side GND or EARTH side GND at the same time.
If above note will not be kept, a fuse or any parts will be broken.
- If any repair has been made to the chassis, it is recommended that the B1 setting should be checked or adjusted (See ADJUSTMENT OF B1 POWER SUPPLY).
- The high voltage applied to the picture tube must conform with that specified in Service manual. Excessive high voltage can cause an increase in X-Ray emission, arcing and possible component damage, therefore operation under excessive high voltage conditions should be kept to a minimum, or should be prevented. If severe arcing occurs, remove the AC power immediately and determine the cause by visual inspection (incorrect installation, cracked or melted high voltage harness, poor soldering, etc.). To maintain the proper minimum level of soft X-Ray emission, components in the high voltage circuitry including the picture tube must be the exact replacements or alternatives approved by the manufacturer of the complete product.
- Do not check high voltage by drawing an arc. Use a high voltage meter or a high voltage probe with a VTVM. Discharge the picture tube before attempting meter connection, by connecting a clip lead to the ground frame and connecting the other end of the lead through a 10kΩ 2W resistor to the anode button.
- When service is required, observe the original lead dress. Extra precaution should be given to assure correct lead dress in the high voltage circuit area. Where a short circuit has occurred, those components that indicate evidence of overheating should be replaced. Always use the manufacturer's replacement components.

10. Isolation Check

(Safety for Electrical Shock Hazard)

After re-assembling the product, always perform an isolation check on the exposed metal parts of the cabinet (antenna terminals, video/audio input and output terminals, Control knobs, metal cabinet, screw heads, earphone jack, control shafts, etc.) to be sure the product is safe to operate without danger of electrical shock.

(1) Dielectric Strength Test

The isolation between the AC primary circuit and all metal parts exposed to the user, particularly any exposed metal part having a return path to the chassis should withstand a voltage of 1100V AC (r.m.s.) for a period of one second. (. . . Withstand a voltage of 1100V AC (r.m.s.) to an appliance rated up to 120V, and 3000V AC (r.m.s.) to an appliance rated 200V or more, for a period of one second.)

This method of test requires a test equipment not generally found in the service trade.

(2) Leakage Current Check

Plug the AC line cord directly into the AC outlet (do not use a line isolation transformer during this check.). Using a "Leakage Current Tester", measure the leakage current from each exposed metal part of the cabinet, particularly any exposed metal part having a return path to the chassis, to a known good earth ground (water pipe, etc.). Any leakage current must not exceed 0.5mA AC (r.m.s.).

However, in tropical area, this must not exceed 0.2mA AC (r.m.s.).

● Alternate Check Method

Plug the AC line cord directly into the AC outlet (do not use a line isolation transformer during this check.). Use an AC voltmeter having 1000 ohms per volt or more sensitivity in the following manner. Connect a 1500Ω 10W resistor paralleled by a 0.15 μF AC-type capacitor between an exposed metal part and a known good earth ground (water pipe, etc.). Measure the AC voltage across the resistor with the AC voltmeter. Move the resistor connection to each exposed metal part, particularly any exposed metal part having a return path to the chassis, and measure the AC voltage across the resistor. Now, reverse the plug in the AC outlet and repeat each measurement. Any voltage measured must not exceed 0.75V AC (r.m.s.). This corresponds to 0.5mA AC (r.m.s.). However, in tropical area, this must not exceed 0.3V AC (r.m.s.). This corresponds to 0.2mA AC (r.m.s.).

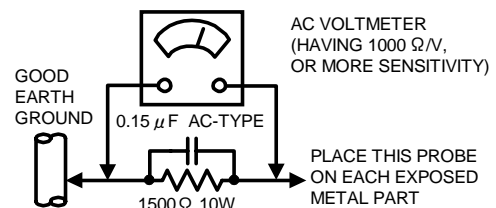

FEATURES

- New chassis design enables use of a main board with simplified circuitry.
- Digital comb filter Improved picture quality.
- Provided with 2 tuner (TV/CATV, PIP).
- Full-square CRT (cathode ray tube) reproduces fine textured picture in every detail.
- With AV COMPU LINK EX terminal.
- Closed-caption broadcasts can be viewed.
- With AUDIO. VIDEO INPUT terminal.
- S-VIDEO input terminal for taking best advantage of Super VHS.
- Variable / Fix audio output terminal.
- Built-in PIP system.
- I²C bus control utilizes single chip ICs.
- Built-in V-CHIP system.
- Built-in HYPER-SURROUND system.

FUNCTIONS

■ REMOTE CONTROL UNIT (RM-C382-1A)

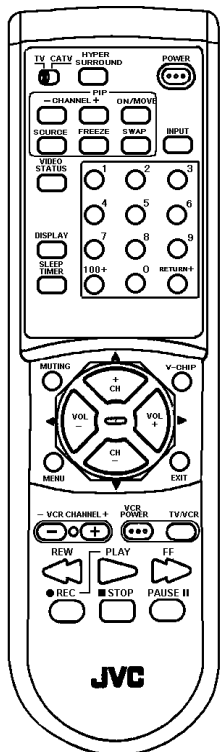

■ FRONT PANEL

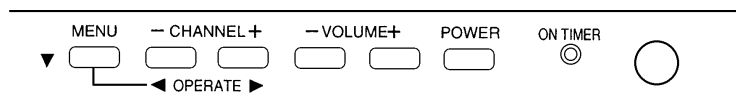
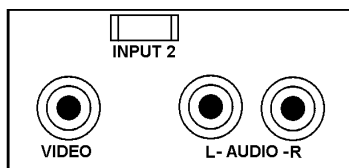

■ REAR PANEL

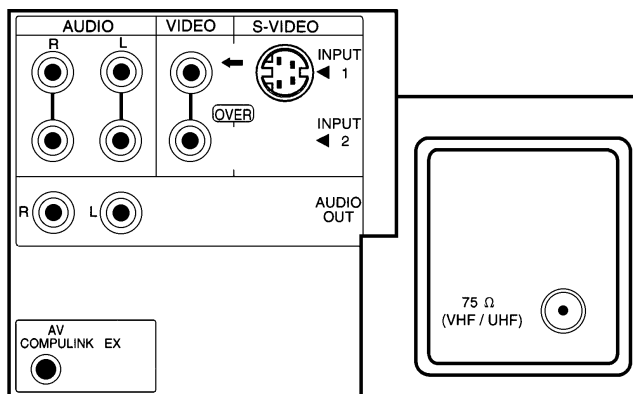

SPECIFIC SERVICE INSTRUCTION

DISASSEMBLY PROCEDURE

REMOVE THE REAR COVER

- Unplug the power plug.
1. Remove the **12** screws marked **(A)** as shown in Fig.2.
 2. Remove the rear cover toward you.

* When reinstalling the rear cover, carefully push it inward after inserting the chassis into the rear cover groove.

REMOVING THE CHASSIS

- After removing the rear cover.
1. Slightly raise the both sides of the chassis by hand and remove the **2** claws under the both sides of the chassis from the front cabinet.
 2. As shown in the Fig.2, withdraw the chassis backward along the rail in the arrow direction marked **(B)** .
(If necessary, take off the wire clamp, connector's etc.)

* When conducting a check with power supplied, be sure to confirm that the CRT earth wire is connected to the CRT SOCKET PWB and the MAIN PWB.

REMOVING THE TERMINAL BOARD

- After removing the rear cover.
1. As shown in Fig.2, remove the **3** screws marked **(C)** .
 2. As shown in Fig.1, after removing the claw marked **(D)** in the direction of arrow mark.
 3. When you pull out the TERMINAL BOARD in the direction of arrow marked **(E)** as shown in Fig.1, it can be removed.

REMOVING THE FRONT CONTROL PW BOARD

- After removing the rear cover and chassis.
1. As shown in Fig.2, remove the **3** screws marked **(F)** .
 2. Then remove the FRONT CONTROL PWB.

REMOVING THE FRONT AV IN PW BOARD

- After removing the rear cover and chassis.
1. As shown in Fig.2, remove the **2** screws marked **(G)** .
 2. Then remove the FRONT AV IN PWB.

REMOVING THE SPEAKER

- After removing the rear cover and chassis.
1. As shown in Fig.2, remove the **4** screws marked **(H)** .
 2. Follow the same steps when removing the other hand speaker.

CHECKING THE MAIN PW BOARD

1. To check the backside of the MAIN PW Board.
 - (1) Pull out the chassis. (Refer to REMOVING THE CHASSIS).
 - (2) Erect the chassis vertically so that you can easily check the backside of the MAIN PW Board.

[CAUTION]

- When erecting the chassis, be careful so that there will be no contacting with other PWB.
- Before turning on power, make sure that the CRT earth wire and other connectors are properly connected.

WIRE CLAMPING AND CABLE TYING

1. Be sure to clamp the wire.
2. Never remove the cable tie used for tying the wires together. Should it be inadvertently removed, be sure to tie the wires with a new cable tie.

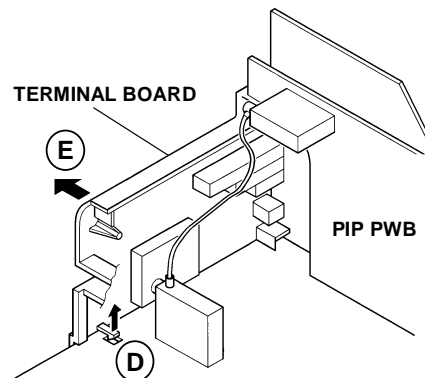

Fig. 1

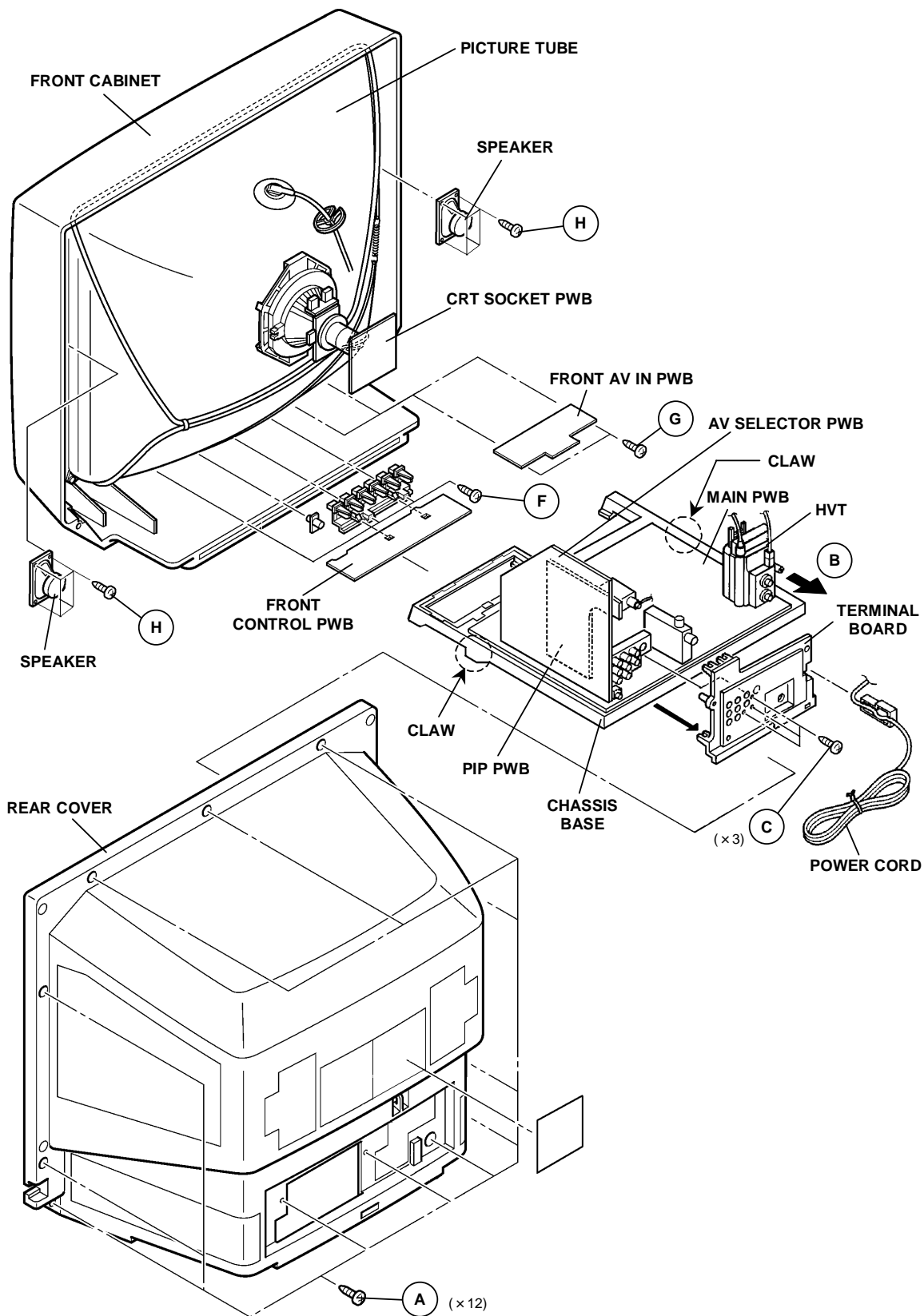

Fig. 2

No. 51738

REMOVING THE CRT

*Replacement of the CRT should be performed by 2 or more persons.

- After removing the rear cover, chassis etc.,
1. Putting the CRT change table on soft cloth, the CRT change table should also be covered with such soft cloth (shown in Fig.3).
 2. While keeping the surface of CRT down, mount the TV set on the CRT change table balanced will as shown in Fig.4.
 3. Remove 4 screws marked by arrows with a box type screwdriver as shown in Fig.4.
- Since the cabinet will drop when screws have been removed, be sure to support the cabinet with hands.
 - 4. After 4 screws have been removed, put the cabinet slowly on cloth (At this time, be carefully so as not to damage the front surface of the cabinet) shown in Fig.5.
 - The CRT should be assembled according to the opposite sequence of its dismantling steps.
- * The CRT change table should preferably be smaller than the CRT surface, and its height be about 35cm.

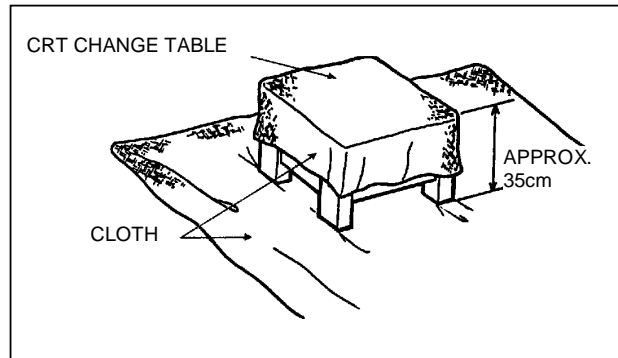

Fig. 3

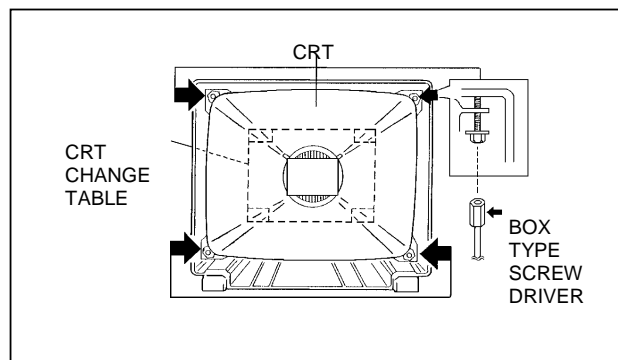

Fig. 4

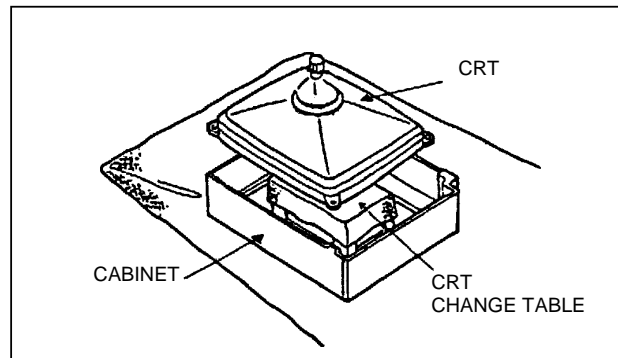

Fig. 5

COATING OF SILICON GREASE FOR ELECTRICAL INSULATION ON THE CRT ANODE CAP SECTION.

- Subsequent to replacement of the CRT and HV transformer or repair of the anode cap, etc. by dismantling them, be sure to coat silicon grease for electrical insulation as shown in Fig.6. Wipe around the anode button with clean and dry cloth. (Fig.6) Coat silicon grease on the section around the anode button. At this time, take care so that any silicon greases dose not sticks to the anode button. (Fig.7)

★ Silicon grease product No. KS - 650N

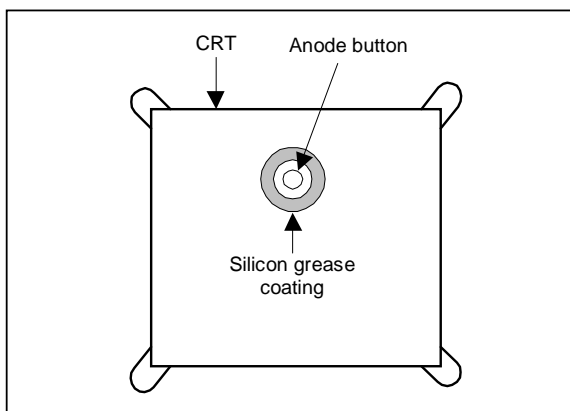

Fig. 6

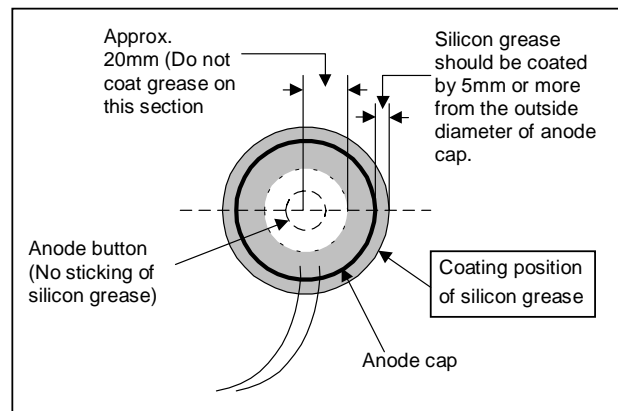

Fig. 7

REPLACEMENT OF CHIP COMPONENT

■ CAUTIONS

1. Avoid heating for more than 3 seconds.
2. Do not rub the electrodes and the resist parts of the pattern.
3. When removing a chip part, melt the solder adequately.
4. Do not reuse a chip part after removing it.

■ SOLDERING IRON

1. Use a high insulation soldering iron with a thin pointed end of it.
2. A 30w soldering iron is recommended for easily removing parts.

■ REPLACEMENT STEPS

1. How to remove Chip parts

◆ Resistors, capacitors, etc

- (1) As shown in the figure, push the part with tweezers and alternately melt the solder at each end.

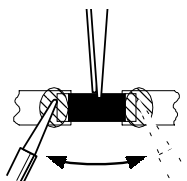

- (2) Shift with tweezers and remove the chip part.

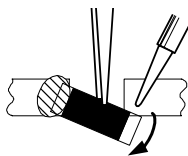

◆ Transistors, diodes, variable resistors, etc

- (1) Apply extra solder to each lead.



- (2) As shown in the figure, push the part with tweezers and alternately melt the solder at each lead. Shift and remove the chip part.

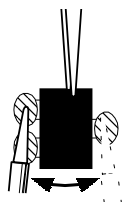

Note : After removing the part, remove remaining solder from the pattern.

2. How to install Chip parts

◆ Resistors, capacitors, etc

- (1) Apply solder to the pattern as indicated in the figure.

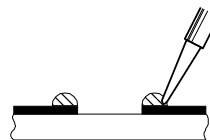

- (2) Grasp the chip part with tweezers and place it on the solder. Then heat and melt the solder at both ends of the chip part.

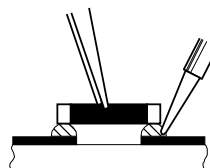

◆ Transistors, diodes, variable resistors, etc

- (1) Apply solder to the pattern as indicated in the figure.
- (2) Grasp the chip part with tweezers and place it on the solder.
- (3) First solder lead **A** as indicated in the figure.

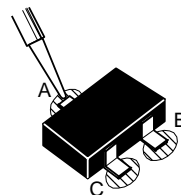

- (4) Then solder leads **B** and **C**.

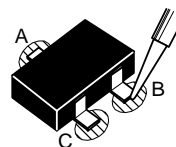

MEMORY IC REPLACEMENT

1. Memory IC

This model uses a memory IC.

This memory IC stores data for proper operation of the video and deflection circuits.

When replacing, be sure to use an IC containing this (initial value) data.

2. Memory IC replacement procedure

Procedure	Screen display												
<p>(1) Power off Switch off the power and disconnect the power cord from the outlet.</p>													
<p>(2) Replace the memory IC Initial value must be entered into the new IC.</p>													
<p>(3) Power on Connect the power cord to the outlet and switch on the power.</p>													
<p>(4) System constant check and setting * It must not adjust without signal.</p> <ol style="list-style-type: none"> 1) Press SLEEP TIMER key and, while the indication of "SLEEP TIMER 0 MIN." is being displayed, press DISPLAY key and VIDEO STATUS key on the remote control unit simultaneously. 2) The SERVICE MENU screen of Fig.1 is displayed. 3) While the SERVICE MENU is displayed, again simultaneously press the DISPLAY and VIDEO STATUS keys to display the Fig.2 SYSTEM CONSTANT screen. 4) Refer to the SYSTEM CONSTANT table and check the setting items. Where these differ, select the setting item with the MENU UP/DOWN key and adjust the setting with the MENU LEFT/RIGHT keys. (The letters of the selected item are displayed in yellow.) 5) After adjusting, release the MENU LEFT/RIGHT key to store the setting value. 6) Press the EXIT key twice to return the normal screen. 	<div data-bbox="938 842 1279 1100" style="border: 1px solid black; padding: 5px;"> <p style="text-align: center;">SERVICE MENU</p> <table style="width: 100%; border-collapse: collapse;"> <tr> <td style="width: 50%;">PICTURE</td> <td style="width: 50%;">SOUND</td> </tr> <tr> <td>THEATER</td> <td>OTHERS</td> </tr> <tr> <td>PIP</td> <td></td> </tr> <tr> <td>LOW LIGHT</td> <td>HIGH LIGHT</td> </tr> <tr> <td>RF AFC 1</td> <td>RF AFC 2</td> </tr> <tr> <td>VCO (CW)</td> <td>I2C BUS CTRL</td> </tr> </table> <p style="text-align: center;">SELECT BY </p> <p style="text-align: center;">OPERATE BY EXIT BY EXIT</p> </div> <p style="text-align: center;">Fig.1</p> <div data-bbox="933 1184 1274 1442" style="border: 1px solid black; padding: 5px;"> <p style="text-align: center;">SYSTEM CONSTANT</p> <p>MODEL : XX-XXXXX</p> <p>CCD : YES</p> <p>BBE : NO</p> <p>V-CHIP : YES</p> <p>CAN V-CHIP : NO</p> <p>XXXXXXXXX XXX</p> <p style="text-align: center;">SELECT BY </p> <p style="text-align: center;">OPERATE BY EXIT BY EXIT</p> </div> <p style="text-align: center;">Fig.2</p>	PICTURE	SOUND	THEATER	OTHERS	PIP		LOW LIGHT	HIGH LIGHT	RF AFC 1	RF AFC 2	VCO (CW)	I2C BUS CTRL
PICTURE	SOUND												
THEATER	OTHERS												
PIP													
LOW LIGHT	HIGH LIGHT												
RF AFC 1	RF AFC 2												
VCO (CW)	I2C BUS CTRL												
<p>(5) Receive channel setting Refer to the OPERATING INSTRUCTIONS (USER'S GUIDE) and set the receive channels (Channels Preset) as described.</p>													
<p>(6) User settings Check the user setting items according to Table 2. Where these do not agree, refer to the OPERATING INSTRUCTIONS (USER'S GUIDE) and set the items as described.</p>													
<p>(7) SERVICE MENU setting Verify what to set in the SERVICE MENU, and set whatever is necessary. (Fig.1) Refer to the SERVICE ADJUSTMENT for setting.</p>													

TABLE 1 (System Constant setting)

Setting item	Setting constant	Setting value	
		AV-N29301	AV-N34301
MODEL		AV-27150	AV-32150
CCD		YES	YES
BBE		NO	NO
V-CHIP		YES	YES
CAN V-CHIP		NO	NO

TABLE 2 (User setting)

Setting item	Setting value	Setting item	Setting value
1. Use remote controller keys			
POWER CHANNEL VOLUME INPUT HYPER SURROUND	OFF CH-02 Proper sound volume TV OFF	DISPLAY VIDEO STATUS SLEEP TIMER PIP SOURCE PIP POSITION	OFF ESTANDAR 0 CH-04 Lower left
2. Settings of MENU			
TINTE COLOR CONTRASTE BRILLO DETALLE PANTALLA AZUL FIJAR VIDEO STATUS GRAVES AGUDOS BALANCE MTS AJUSTE DEL RELOJ TEMPORIZADOR	CENTER CENTER CENTER CENTER CENTER SI ALL CENTER CENTER CENTER CENTER ESTEREO Unnecessary to set NO	ALTAVOCES SALIDA AUDIO IDIOMA SUBTITULOS OCULTOS AUTOPROGRAMACION LISTA DE CANALES V-CHIP BLOQUEO DE CANAL	SI FIX ESP. MODO : NO MODO : TV Unnecessary to set OFF (SET US TV RATINGS } ALL SET MOVIE RATINGS } CLEAR UNRATED : VIEW) Unnecessary to set

SERVICE ADJUSTMENTS

ADJUSTMENT PREPARATION:

1. You can make the necessary adjustments for this unit with either the remote control unit or with the adjustment equipment and parts as given below.
2. Adjustment with the remote control unit is made on the basis of the initial setting values, however, the new setting values which set the screen to its optimum condition may differ from the initial settings.
3. Make sure that AC power is turned on correctly.
4. Turn on the power for the set and test equipment before use, and start the adjustment procedures after waiting at least 30 minutes.
5. Unless otherwise specified, prepare the most suitable reception or input signal for adjustment.
6. Never touch any adjustment parts, which are not specified in the list for this adjustment-variable resistors, transformers, condensers, etc.
7. Presetting before adjustment.

Unless otherwise specified in the adjustment instructions, preset the following functions with the remote control unit.

VIDEO STATUS	ESTANDAR
HYPER SURROUND	OFF
GRAVAS, AGUDOS, BALANCE	CENTER
TINTE, COLOR, CONTRASTE, BRILLO, DETALLE	CENTER

MEASURING INSTRUMENT

1. DC voltmeter(or digital voltmeter)
2. Oscilloscope
3. Signal generator (Pattern generator) [NTSC]
4. Remote control unit
5. TV audio multiplex signal generator
6. Frequency counter

ADJUSTMENTS

- Check of B1 POWER SUPPLY
- IF VCO adjustment
- RF AGC adjustment
- FOCUS adjustment
- DEFLECTION adjustment
 - V. CENTER, V. SIZE, V. POSITION adjustment
 - H. WIDTH, SIDEPIN CORRECT and H. POSITION adjustment
- VIDEO / CHROMA adjustment
 - WHITE BALANCE (Low light) adjustment
 - WHITE BALANCE (High light) adjustment
 - SUB BRIGHT adjustment
 - SUB CONTRAST adjustment
 - SUB COLOR adjustment
 - SUB TINT adjustment
- PIP circuit adjustment
 - WHITE BALANCE adjustment
 - DISPLAY POSITION adjustment
- MTS circuit adjustment
 - INPUT LEVEL check
 - STEREO VCO adjustment
 - SAP VCO adjustment
 - FILTER check
 - SEPARATION adjustment

ADJUSTMENT LOCATIONS

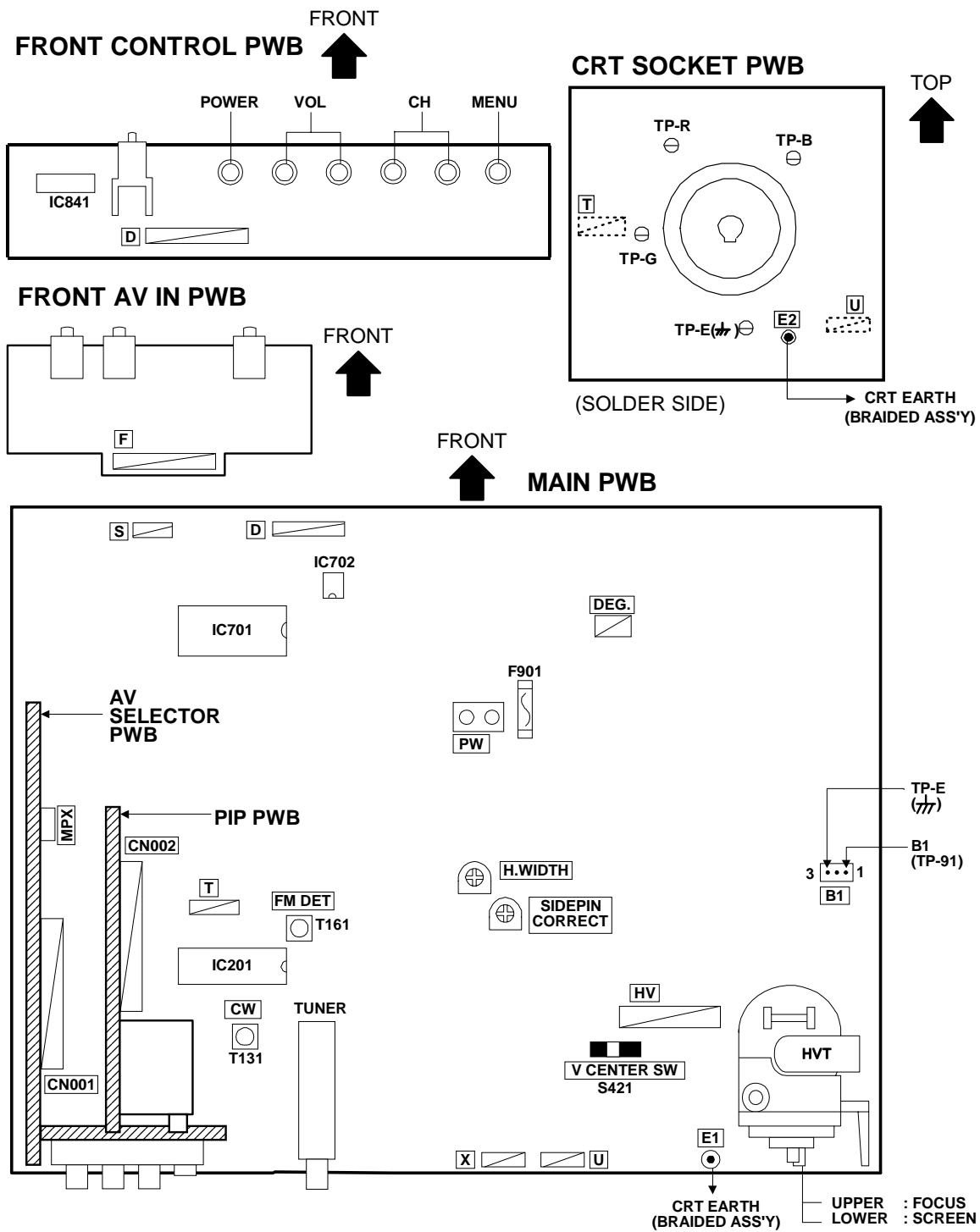

BASIC OPERATION OF SERVICE MENU

1. TOOL OF SERVICE MENU OPERATION

Operate the SERVICE MENU with the REMOTE CONTROL UNIT.

2. SERVICE MENU ITEMS

In general, basic setting (adjustments) items or verifications are performed in the SERVICE MENU.

- PICTURE This set the setting values (adjustment values) of the VIDEO/CHROMA and DEFLECTION circuits.
- SOUND This set the setting values (adjustment values) of the AUDIO circuit.
- THEATER This is used when the THEATER MODE is adjusted.
- OTHERS This is used when the OTHERS MODE is adjusted.
- PIP This set the setting values (adjustment values) of the PICTURE-IN-PICTURE circuit.
(PIP is means as Picture in Picture)
- LOW LIGHT This sets the setting values (adjustment values) of the WHITE BALANCE circuit.
- HIGH LIGHT This sets the setting values (adjustment values) of the WHITE BALANCE circuit.
- RF AFC 1 This is used when the RF AFC 1 MODE is verified. **[Do not adjust]**
- RF AFC 2 This is used when the RF AFC 2 MODE is verified. **[Do not adjust]**
- VCO (CW) This is used when the IF VCO is adjusted.
- I²C BUS CTRL This is used when ON/OFF of the I²C BUS CTRL is set. **[Fixed ON]**

3. Basic Operations of the SERVICE MENU

(1) How to enter the SERVICE MENU.

Press **SLEEP TIMER** key and, while the indication of "**SLEEP TIMER 0 MIN.**" is being displayed, press **DISPLAY** key and **VIDEO STATUS** key on the remote control unit simultaneously to enter the **SERVICE MENU** screen ① shown in the next figure page.

(2) SERVICE MENU screen selection

Press the UP / DOWN key of the MENU to select any of the following items.

(The letters of the selected items are displayed in yellow.)

- | | |
|-------------|-----------------------------|
| ● PICTURE | ● SOUND |
| ● THEATER | ● OTHERS |
| ● PIP | |
| ● LOW LIGHT | ● HIGH LIGHT |
| ● RF AFC 1 | ● RF AFC 2 |
| ● VCO (CW) | ● I ² C BUS CTRL |

(3) Enter the any setting (adjustment) mode

● PICTURE, SOUND and OTHERS mode

- 1) If select any of PICTURE, SOUND or OTHERS items, and the LEFT / RIGHT key is pressed from SERVICE MENU (MAIN MENU), the screen ② will be displayed as shown in figure page later.
- 2) Then the UP / DOWN key is pressed, the PICTURE mode screen ③ or the SOUND mode screen ④ or the OTHERS mode screen ⑤ is displayed, and the PICTURE, SOUND or OTHERS setting can be performed.

● PIP mode

- 1) If select the PIP item, and the LEFT / RIGHT key is pressed from SERVICE MENU (MAIN MENU), the screen ⑥ will be displayed as shown in figure page later.
- 2) Then UP / DOWN key is pressed, the PIP mode screen ⑦ is displayed, and the PIP setting can be performed.

● THEATER, LOW LIGHT, HIGH LIGHT, RF AFC1, RF AFC2, VCO (CW) and I²C BUS CTRL mode

- 1) If select any of THEATER / LOW LIGHT / HIGH LIGHT / RF AFC 1 / RF AFC 2 / VCO (CW) / I²C BUS CTRL items, and the LEFT / RIGHT key is pressed from SERVICE MENU (MAIN MENU), the screens ⑧ ⑨ ⑩ ⑪ ⑫ ⑬ ⑭ will be displayed as shown in figure page later.
- 2) Then the settings or verifications can be performed.

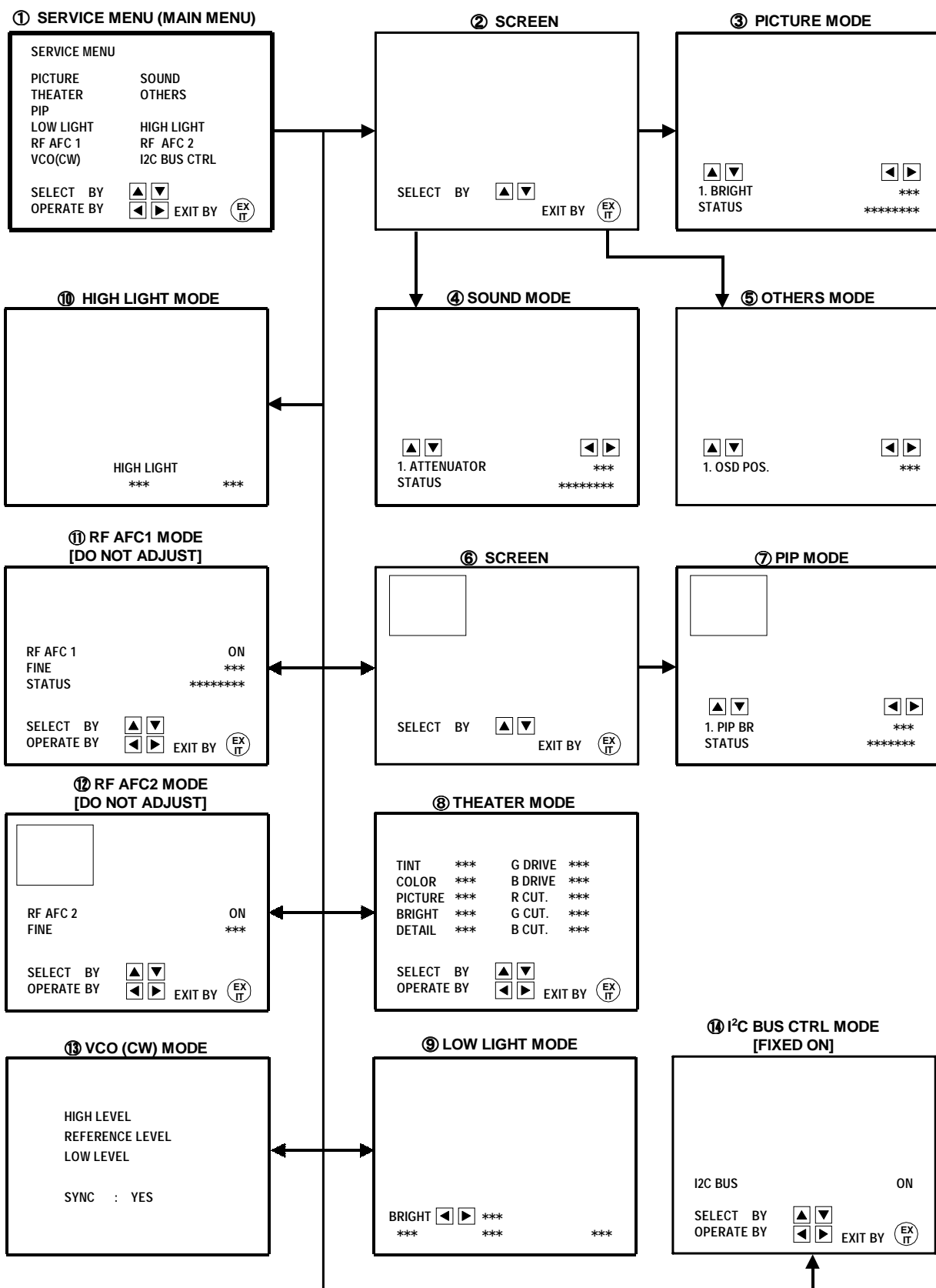

(4) Setting method

- 1) UP / DOWN key of the MENU
Select the SETTING ITEM.
- 2) LEFT / RIGHT key of the MENU
Setting (adjust) the SETTING VALUE of the SETTING ITEM.
When the key is released the SETTING VALUE will be stored (memorized).
- 3) EXIT key
Returns to the previous screen.

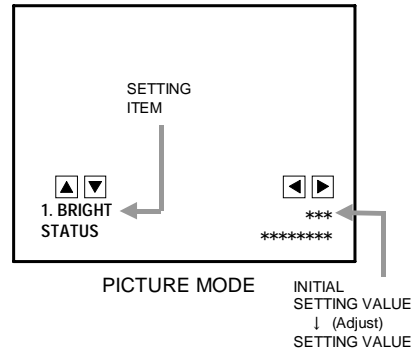

(5) Releasing SERVICE MENU

- 1) After returning to the SERVICE MENU upon completion of the setting (adjustment) work, press the EXIT key again.

- ★ The settings for LOW LIGHT and HIGH LIGHT are described in the WHITE BALANCE page of ADJUSTMENT.
- ★ The setting for VCO (CW) are described in the IF VCO page of ADJUSTMENT.

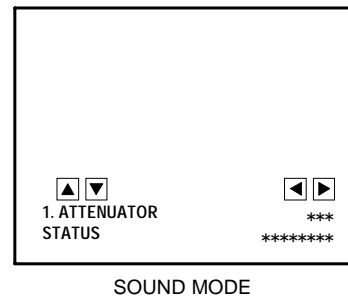

The letters of the selected items are displayed in yellow.

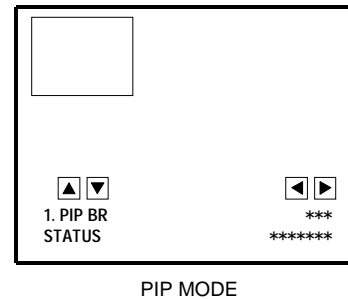
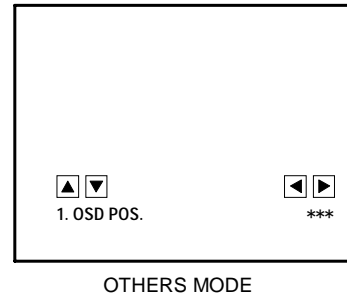
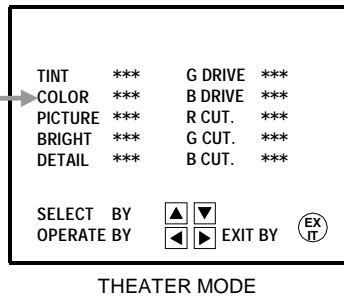

INITIAL SETTING VALUE OF SERVICE MENU

1. Adjustment of the SERVICE MENU is made on the basis of the initial setting values; however, the new setting values which set the screen in its optimum condition may differ from the initial setting.
2. Do not change the initial Setting Values of the Setting (Adjustment) items not listed in "ADJUSTMENT".

● PICTURE MODE

- ◇ The four setting items in the video mode No.8 EXT BRI., No.9 EXT PIC., No.12 EXT TINT and No.13 EXT COLOR are linked to the items in the TV MODE No.1 BRIGHT, No.2 PICTURE, No.6 TINT and No.7 COLOR, respectively. When the setting items in the TV mode are adjusted, the values in the setting items in the video mode are revised automatically to the same values in the TV mode. (The initial setting values given in () are off-set values.)
- ◇ When the four items (No.8, 9, 12 and 13) are adjusted in the video mode, the setting values in each item are revised independently.

No.	Setting (Adjustment) item	Variable range	Initial setting value	
			AV-N29301	AV-N34301
1.	BRIGHT	000~127	064	064
2.	PICTURE	000~127	088	090
3.	WPS (WHITE PEAK SUPPRESSOR)	000 / 001	001	001
4.	TV DETAIL	000~063	040	040
5.	TV BPF (TV B.P.FILTER)	000 / 001	001	001
6.	TINT	000~127	067	074
7.	COLOR	000~127	047	053
8.	EXT BRIGHT	±25	(+001)	(+001)
9.	EXT PICT.	±25	(±000)	(±000)
10.	EXT DETAIL	000~063	038	038
11.	EXT BPF (EXT B.P.FILTER)	000 / 001	001	001
12.	EXT TINT	±25	(+002)	(+007)
13.	EXT COLOR	±25	(+003)	(+005)
14.	V SIZE	000~063	015	033
15.	V CENTER	000~007	000	000
16.	H POSITION	000~031	022	022
17.	H AFC	000 / 001	000	000
18.	BLANKING	000 / 001	000	000
19.	RF AGC	000~063	035	035
20.	PIF VCO	000~127	064	064

● SOUND MODE

No	Setting (Adjustment) item	Variable range	Initial setting value
1.	ATTENUATOR	000~063	050
2.	BALANCE	000~063	032
3.	NOISE DET.	000 / 001	001
4.	IN LEVEL (INPUT LEVEL)	000~063	027
5.	FH MONITOR	000 / 001	000
6.	STEREO VCO	000~063	023
7.	PILOT CAN. (PILOT CANCELER)	000 / 001	000
8.	FILTER	000~063	030
9.	LOW SEP. (LOW SEPARATION)	000~063	028
10.	HI SEP. (HIGH SEPARATION)	000~063	019
11.	5FH MON. (5FH MONITOR)	000 / 001	000
12.	SAP VCO	000~063	027
13.	IN GAIN	000 / 001	000
14.	FIL. OFFSET	±010	±000
15.	BBE BASS	±010	-001
16.	BBE TRE	±010	-001

● THEATER MODE

Setting (Adjustment) item	Variable range	Initial setting value
TINT	±20	±00
COLOR	±20	-02
PICTURE	-30~+20	-15
BRIGHT	±20	±00
DETAIL	±15	-03
G DRIVE	-99~+50	-25
B DRIVE	-99~+50	-72
R CUT. (R CUTOFF)	±10	±00
G CUT. (G CUTOFF)	±10	±00
B CUT. (B CUTOFF)	±10	±00

● OTHERS MODE

No.	Setting (Adjustment) item	Variable range	Initial setting value	
			AV-N29301	AV-N34301
1.	OSD POS.	000~007	000	000
2.	CCD POS. (CLOSED CAPTION DECODER POS.)	000~015	002	004
3.	ESEL	000 / 001	000	000
4.	F1_FIELD	000 / 001	000	000
5.	F1_LINE21	000~015	008	008
6.	F2_LINE21	000~015	008	008
7.	OSD STABI.	000 / 001	000	000
8.	SYNC SEP.	000 / 001	001	001
9.	MENU COLOR	-030~±000	-010	-010
10.	MENU PICT	-030~±000	-012	-012
11.	MENU BRI	-030~±000	-012	-012
12.	TU1 FM TRP	000 / 001	000	000
13.	TU2 FM TRP	000 / 001	000	000

● PIP MODE

No.	Setting (Adjustment) item	Variable range	Initial setting value	
			AV-N29301	AV-N34301
1.	PIP BR	000~015	005	007
2.	PIP PICT	000~075	045	045
3.	PIP TINT	000~063	032	034
4.	PIP COL	000~015	009	009
5.	P R CUT	000~015	000	000
6.	P G CUT	000~015	000	000
7.	P B CUT	000~015	000	000
8.	P R DR	000~255	128	131
9.	P G DR	000~255	128	131
10.	P B DR	000~255	128	131
11.	LEFT POS.	000~255	019	019
12.	RIGHT POS	000~255	019	019
13.	UPPER POS.	000~127	012	012
14.	LOWER POS	000~127	011	011
15.	PICT LOCK	000 / 001	000	000
16.	SELDEL	000~015	000	000
17.	AGCFIX	000 / 001	001	001
18.	AGCADST	000 / 001	000	000
19.	AGC	000~015	007	007
20.	VSPDEL	000~031	000	000

No.	Setting (Adjustment) item	Variable range	Initial setting value	
			AV-N29301	AV-N34301
21.	VSPISQ	000 / 001	001	001
22.	YCOR	000 / 001	001	001
23.	XFREQF	000 / 001	001	001
24.	WTCHDG	000 / 001	001	001
25.	COLON	000 / 001	000	000
26.	ACQNEW	000 / 001	000	000
27.	DSTDET	000 / 001	001	001
28.	CRIBEOK	000 / 001	000	000
29.	FCBEOK	000 / 001	000	000
30.	NOCRID	000 / 001	000	000
31.	NONSED	000 / 001	000	000

● LOW LIGHT MODE

Setting (Adjustment) item	Variable range	Initial setting value
R CUTOFF	000~255	020
G CUTOFF	000~255	020
B CUTOFF	000~255	020

● HIGH LIGHT MODE

Setting (Adjustment) item	Variable range	Initial setting value
G DRIVE	000~255	128
B DRIVE	000~255	128

● RF AFC 1 MODE

Setting (Adjustment) item	Variable range	Initial setting value
RF AFC 1 FINE	ON/OFF -77~+77	ON (DO NOT ± x x ADJUST)

● RF AFC 2 MODE

Setting (Adjustment) item	Variable range	Initial setting value
RF AFC 2 FINE	ON/OFF -77~+77	ON (DO NOT ± x x ADJUST)

● I²C BUS CTRL MODE

Setting (Adjustment) item	Variable range	Initial setting value
I ² C BUS	ON/OFF	[Fixed ON]

■ ADJUSTMENTS

B1 POWER SUPPLY

Item	Measuring instrument	Test point	Adjustment part	Description
Check of B1 POWER SUPPLY	DC Voltmeter	B1 (【B1】 Connector 【1】 pin) (TP-91) TP-E(⚡) (【B1】 Connector 【3】 pin)		<ol style="list-style-type: none"> 1. Receive a black-and-white signal. (Color off) 2. Connect the DC Voltmeter to 【B1】 connector 【1】 pin (TP-91) and TP-E(⚡) (B1 connector 【3】 pin). 3. Confirm that the voltage is DC134V±2V.

ADJUSTMENT OF IF. VCO

Item	Measuring instrument	Test point	Adjustment part	Description
IF VCO adjustment	Signal generator		CW TRANSF. (T131) [VCO(CW)] MODE	<ul style="list-style-type: none"> ● Under normal conditions, no adjustment is required. <ol style="list-style-type: none"> 1. Receive a NTSC aerial broadcast. 2. Select the VCO (CW) mode from the SERVICE MENU. 3. Confirm that the color change from 「HIGH LEVEL」 to 「LOW LEVEL」 by CW transf. and check the 「SYNC : YES」 . 4. Adjust until 「REFERENCE LEVEL」 mark turns yellow. and then confirm that the 「SYNC : YES」 again.

HIGH LEVEL
REFERENCE LEVEL ← YELLOW
LOW LEVEL

SYNC : YES

ADJUSTMENT OF RF AGC

Item	Measuring instrument	Test point	Adjustment part	Description
RF. AGC adjustment			No.19 RF AGC	<ol style="list-style-type: none"> 1. Receive a broadcast. 2. Select "No.19 RF AGC" of the PICTURE MODE. 3. Press the MUTE key and turn off color. 4. With the MENU LEFT key, get noise in the screen picture. (0 side of setting value) 5. Press the MENU RIGHT key and stop when noise disappears from the screen. 6. Change to other channels and make sure that there is no irregularity. 7. Press the MUTE key and get color out.

ADJUSTMENT OF FOCUS

Item	Measuring instrument	Test point	Adjustment part	Description
FOCUS adjustment	Signal generator		FOCUS VR [In HVT]	<ol style="list-style-type: none"> 1. Receive a crosshatch signal. 2. While looking at the screen, adjust FOCUS VR so that the vertical and horizontal lines will be clear and in fine detail. 3. Make sure that the picture is in focus even when the screen gets darkened.

ADJUSTMENT OF DEFLECTION CIRCUIT

Item	Measuring instrument	Test point	Adjustment part	Description
V.CENTER, V.SIZE and V.POSITION adjustment	Signal generator		No.14 V SIZE No.15 V CENTER V.CENTER SW (S1421)	<ol style="list-style-type: none"> 1. Receive a crosshatch signal. 2. Make sure that the "No.15 V CENTER" of the PICTURE SERVICE MODE is 0. 3. Use the LEFT/RIGHT keys of the MENU to set the initial setting value for the No.14 V SIZE. 4. Adjust the vertical SCREEN size to 90%(AV-N29301) / 92%(AV-N34301) with the No.14 V SIZE and S1421 (V.CENTER SW). <p>NOTE :</p> <ul style="list-style-type: none"> • Bottom of screen is to be located within the 83% ~ 93%(AV-N29301) / 85%~95%(AV-N34301) range.
H.WIDTH, SIDEPIN CORRECT and H.POSITION Adjustment	Signal generator		No.16 H POSITION SIDEPIN CORRECT VR (R1579) H.WIDTH VR (R1581)	<ol style="list-style-type: none"> 1. Receive a crosshatch signal. 2. Adjust the SIDEPIN CORRECT. VR(R1579) so that vertical lines at both side of the crosshatch are straight. 3. Select the "No.16 H POSITION" of the PICTURE SERVICE MODE. 4. Press the LEFT/RIGHT keys of the MENU to set the initial setting values for the "No.16 H POSITION". 5. Adjust the "No.16 H POSITION" until the screen will be horizontally centered. 6. Adjust the H.WIDTH VR(R1581) so that 90%(AV-N29301) / 92%(AV-N34301) of the overall crosshatch is displayed on the screen. 7. As required, repeat above steps 2 and 6.

ADJUSTMENT OF VIDEO / CHROMA CIRCUIT

Item	Measuring instrument	Test point	Adjustment part	Description
<p>WHITE BALANCE (Low Light) adjustment</p>	<p>Signal generator</p>		<p>BRIGHT R CUTOFF G CUTOFF B CUTOFF SCREEN VR</p>	<ol style="list-style-type: none"> 1. Receive a black-and-white signal. (Color off) 2. Select the [LOW LIGHT] MODE from the SERVICE MENU. 3. Set the initial setting value of "BRIGHT" is 64, with the LEFT/RIGHT key of the remote control unit. 4. Set the initial setting value of "R CUTOFF", "G CUTOFF" and "B CUTOFF" is 20, with the ④ to ⑨ keys of the remote control unit. 5. Display a single horizontal line by pressing the ① key of the remote control unit. 6. Turn the screen VR all the way to the left. 7. Turn the screen VR gradually to the right from the left until either one of the red, blue or green colors appears faintly. 8. Adjust the two colors which did not appear until the single horizontal line that is displayed becomes white using the ④ to ⑨ keys of the remote control unit. 9. Turn the screen VR until the single horizontal line is displayed faintly. 10. Press the ② key to return to the regular screen. <p>* The ③ EXIT key is the cancel key for the WHITE BALANCE.</p>
<p>WHITE BALANCE (High Light) adjustment</p>	<p>Signal generator</p>		<p>G DRIVE B DRIVE</p>	<ol style="list-style-type: none"> 1. Receive a black-and-white signal. (Color off) 2. Select the [HIGH LIGHT] MODE in the SERVICE MENU. 3. Set the initial setting value of "G DRIVE" and "B DRIVE" with the ⑤, ⑥, ⑧ and ⑨ keys of the remote control unit. 4. Adjust the screen until it becomes white using the ⑤, ⑥, ⑧ and ⑨ keys of the remote control unit. <p>* The ③ EXIT key is the cancel key for the WHITE BALANCE.</p>

[LOW LIGHT] MODE

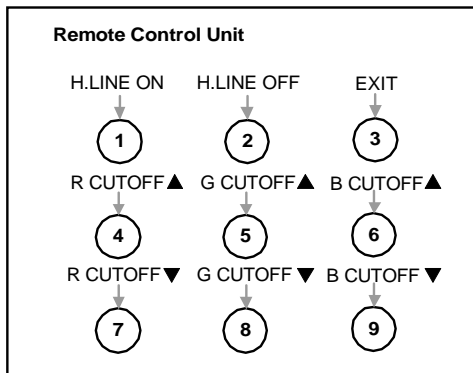
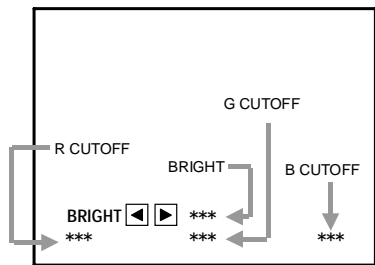

[HIGH LIGHT] MODE

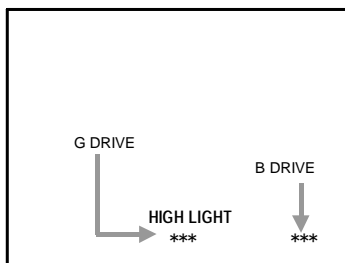

Remote Control Unit

- ①key : H.LINE ON
- ②key : H.LINE OFF
- ③key : EXIT
- ⑤key : G DRIVE ▲
- ⑥key : B DRIVE ▲
- ⑧key : G DRIVE ▼
- ⑨key : B DRIVE ▼

Item	Measuring instrument	Test point	Adjustment part	Description						
SUB BRIGHT adjustment			No.1 BRIGHT	<ol style="list-style-type: none"> 1. Receive a broadcast. 2. Select "No.1 BRIGHT" of the PICTURE MODE. 3. Set the initial setting value of the "No.1 BRIGHT" with the LEFT/RIGHT key of the MENU. 4. If the brightness is not the best with the initial setting value, make fine adjustment of the "No.1 BRIGHT" until you get the optimum brightness. 						
SUB CONTRAST adjustment			No.2 PICTURE	<ol style="list-style-type: none"> 1. Receive a broadcast. 2. Select "No.2 PICTURE" of the PICTURE MODE. 3. Set the initial setting value of the "No.2 PICTURE" with the LEFT/RIGHT key of the MENU. 4. If the contrast is not the best with the initial setting value, make fine adjustment of the "No.2 PICTURE" until you get the optimum contrast. 						
SUB COLOR adjustment	Signal Generator Oscilloscope	TP-B TP-E(↕) [CRT SOCKET PWB]	No.7 COLOR	<p>[Method of adjustment without measuring instrument]</p> <ol style="list-style-type: none"> 1. Receive a broadcast. 2. Select "No.7 COLOR" of the PICTURE MODE. 3. Set the initial setting value of the "No.7 COLOR" with the LEFT/RIGHT key of the MENU. 4. If the color is not the best with the Initial setting value, make fine adjustment of the "No.7 COLOR" until you get the optimum color. <p>[Method of adjustment using measuring instrument]</p> <ol style="list-style-type: none"> 1. Receive a fill field color bar signal (75% white) . 2. Select No.7 COLOR of the PICTURE MODE. 3. Set the initial setting values of the No.7 COLOR with the LEFT/RIGHT key of the MENU. 4. Connect the oscilloscope between TP-B and TP-E. 5. Adjust TINT and bring the value of (A) in the illustration to the voltage shown in the table below (V_{W-B}). <table border="1" style="margin-left: auto; margin-right: auto;"> <thead> <tr> <th>Model</th> <th>Voltage(W-B)</th> </tr> </thead> <tbody> <tr> <td>AV-N29301</td> <td>+1V</td> </tr> <tr> <td>AV-N34301</td> <td>+16V</td> </tr> </tbody> </table>	Model	Voltage(W-B)	AV-N29301	+1V	AV-N34301	+16V
Model	Voltage(W-B)									
AV-N29301	+1V									
AV-N34301	+16V									
SUB TINT adjustment	Signal Generator Oscilloscope	TP-B TP-E(↕) [CRT SOCKET PWB]	No.6 TINT	<p>[Method of adjustment without measuring instrument]</p> <ol style="list-style-type: none"> 1. Receive a broadcast. 2. Select "No.6 TINT" of the PICTURE MODE. 3. Set the initial setting value of the "No.6 TINT" with the LEFT/RIGHT key of the MENU. 4. If the tint is not the best with the initial setting value, make fine adjustment of the "No.6 TINT" until you get the optimum tint. <p>[Method of adjustment using measuring instrument]</p> <ol style="list-style-type: none"> 1. Receive a fill field color bar signal (75% white). 2. Select No.6 TINT of the PICTURE MODE. 3. Set the initial setting value of the No.6 TINT with the LEFT/RIGHT key of the MENU. 4. Connect the oscilloscope between TP-B and TP-E. 5. Adjust TINT and bring the value of (B) in the illustration to the voltage shown in the table below (V_{W-Mg}). <table border="1" style="margin-left: auto; margin-right: auto;"> <thead> <tr> <th>Model</th> <th>Voltage (W-Mg)</th> </tr> </thead> <tbody> <tr> <td>AV-N29301</td> <td>0V</td> </tr> <tr> <td>AV-N34301</td> <td>+12V</td> </tr> </tbody> </table>	Model	Voltage (W-Mg)	AV-N29301	0V	AV-N34301	+12V
Model	Voltage (W-Mg)									
AV-N29301	0V									
AV-N34301	+12V									

ADJUSTMENT OF PIP CIRCUIT

Item	Measuring instrument	Test point	Adjustment part	Description
PIP WHITE BALANCE adjustment	Signal generator		No. 9 P G DR No.10 P B DR	<ul style="list-style-type: none"> Select the "No.2 PIP PICT" of the PIP SERVICE MODE. Verify that the "No.2 PIP PICT " is set at its initial setting value. 1. Receive a black-and-white signal.(Color off) 2. Select the "No.9 P G DR, No.10 P B DR" of the PIP SERVICE MODE. 3. Set the corresponding initial setting values with the LEFT/RIGHT key of the menu. 4. Adjust the "No.9 P G DR, No.10 P B DR" until the screen becomes white.
PIP DISPLAY POSITION adjustment	Signal generator		No.11 LEFT POS. No.12 RIGHT POS. No.13 UPPER POS. No.14 LOWER POS.	<ol style="list-style-type: none"> 1. Receive a black-and-white signal.(Color off) 2. Select the "No.11 LEFT POS." of the PIP SERVICE MODE. 3. Set the initial setting value of the No.11 LEFT POS." with the LEFT/RIGHT key of the menu. 4. Adjust the "No.11 LEFT POS." so that the position of the PIP screen edge of left will be at Y1 as shown. 5. Adjust the corresponding modes of "No.12, No.13, No.14" with the same steps as 2~4 above.

PIP SERVICE MODE No.	Item	PIP Setting position	
		Approx. (mm)	
		29" model	34" model
No.11	LEFT POSITION (Y1)	40	45
No.12	RIGHT POSITION (Y2)	40	45
No.13	UPPER POSITION (X1)	30	35
No.14	LOWER POSITION (X2)	30	35

ADJUSTMENT OF MTS CIRCUIT

Item	Measuring instrument	Test point	Adjustment part	Description
MTS INPUT LEVEL check			No.4 IN LEVEL	<ol style="list-style-type: none"> 1. Select the "No.4 IN LEVEL" of the SOUND MODE. 2. Verify that the "No.4 IN LEVEL" is set at its initial setting value.
MTS STEREO VCO adjustment	<p>Signal generator</p> <p>Frequency counter</p>	R OUT [AUDIO OUT]	<p>No.5 FH MONITOR</p> <p>No.6 STEREO VCO</p>	<ol style="list-style-type: none"> 1. Receive a RF signal (nonmodulated sound signal) from the antenna terminal. 2. Select the "No.5 FH MONITOR" of SOUND MODE, and change the setting value from 0 to 1. 3. Connect the Frequency Counter to R OUT RCA pin of the AUDIO OUT. 4. Select the "No.6 STEREO VCO". 5. Set the initial setting value of the "No.6 STEREO VCO" with the LEFT/RIGHT key of the menu. 6. Adjust the "No.6 STEREO VCO" so that the Frequency Counter will display $15.73\text{kHz} \pm 0.1\text{kHz}$. 7. Select the "No.5 FH MONITOR" of the SOUND MODE, and reset the setting value from 1 to 0.

Item	Measuring instrument	Test point	Adjustment part	Description
MTS SAP VCO adjustment	Signal generator	[MPX] Connector [4] pin SDA [3] pin GND [AV SELECTOR PWB] R OUT [AUDIO OUT]	No.11 5FH MON. No.12 SAP VCO	<ol style="list-style-type: none"> 1. Receive a RF signal (non-modulated sound signal) from the antenna terminal. 2. Connect between pin [4] of [MPX] connector and GND (Pin [3] of [MPX] connector) through 1MΩ Resistor. 3. Select the "No.11 5FH MON." of the SOUND MODE, and reset the1 setting value from 0 to 1. 4. Connect the Frequency counter to R OUT RCA pin of the AUDIO OUT. 5. Select the "No.12 SAP VCO". 6. Set the initial setting value of "No.12 SAP VCO" with the LEFT/RIGHT key of the menu. 7. Adjust the "No.12 SAP VCO" so that the Frequency Counter will display 78.67kHz±0.5kHz. 8. Select the "No.11 5FH MON." of the SOUND MODE, and reset the setting value from 1 to 0.
MTS FILTER check			No.8 FILTER	<ol style="list-style-type: none"> 1. Select the "No.8 FILTER" of the SOUND MODE. 2. Verify that the "No.8 FILTER" is set at its initial setting value.
MTS SEPARATION adjustment	TV audio multiplex signal generator Oscilloscope	L OUT R OUT [AUDIO OUT]	No.9 LOW SEP. No.10 HI SEP.	<ol style="list-style-type: none"> 1. Input a stereo L signal (300Hz) from the TV audio multiplex signal generator to the antenna terminal. 2. Connect an oscilloscope to L OUT RCA pin of the AUDIO OUT, and display one cycle portion of the 300Hz signal. 3. Change the connection of the oscilloscope to R OUT RCA pin of the AUDIO OUT, and enlarge the voltage axis. 4. Select the "No.9 LOW SEP." of the SOUND MODE. 5. Set the initial setting value of the "No.9 LOW SEP." with the LEFT/RIGHT key of the menu. 6. Adjust the "No.9 LOW SEP." so that the stroke element of the 300Hz signal will become minimum. 7. Change the signal to 3kHz, and similarly adjust the "No.10 HI SEP.".

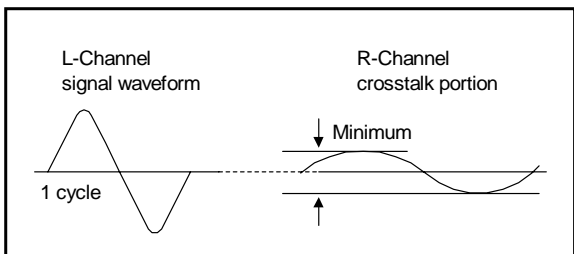

PURITY, CONVERGENCE

PURITY ADJUSTMENT

1. Demagnetize CRT with the demagnetizer.
2. Loosen the retainer screw of the deflection yoke.
3. Remove the wedges.
4. Input a green raster signal from the signal generator, and turn the screen to green raster.
5. Move the deflection yoke backward.
6. Bring the long lug of the purity magnets on the short lug and position them horizontally. (Fig.2)
7. Adjust the gap between two lugs so that the GREEN RASTER will come into the center of the screen. (Fig.3)
8. Move the deflection yoke forward, and fix the position of the deflection yoke so that the whole screen will become green.
9. Insert the wedge to the top side of the deflection yoke so that it will not move.
10. Input a crosshatch signal.
11. Verify that the screen is horizontal.
12. Input red and blue raster signals, and make sure that purity is properly adjusted.

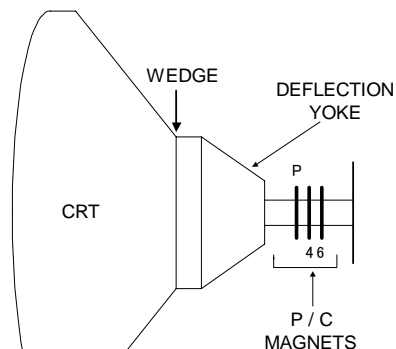

• P/C MAGNETS

P : PURITY MAGNET
4 : 4 POLES (convergence magnets)
6 : 6 POLES (convergence magnets)

Fig.1

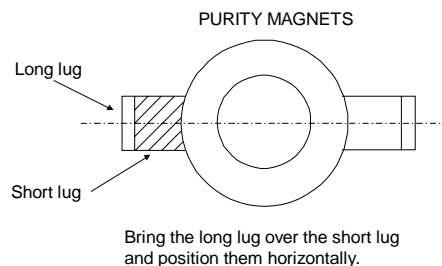

Fig.2

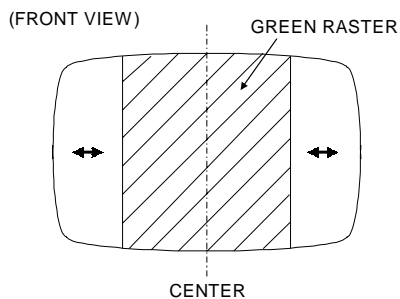

Fig.3

STATIC CONVERGENCE ADJUSTMENT

1. Input a crosshatch signal.
2. Using 4-pole convergence magnets, overlap the red and blue lines in the center of the screen (Fig.1) and turn them to magenta (red/blue).
3. Using 6-pole convergence magnets, overlap the magenta(red/blue) and green lines in the center of the screen and turn them to white.
4. Repeat 2 and 3 above, and make best convergence.

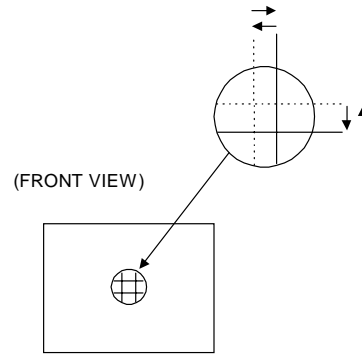

Fig.1

DYNAMIC CONVERGENCE ADJUSTMENT

1. Move the deflection yoke up and down and overlap the lines in the periphery. (Fig. 2)
 2. Move the deflection yoke left to right and overlap the lines in the periphery. (Fig. 3)
 3. Repeat 1 and 2 above, and make best convergence.
- After adjustment, fix the wedge at the original position. Fasten the retainer screw of the deflection yoke. Fix the 6 magnets with glue.

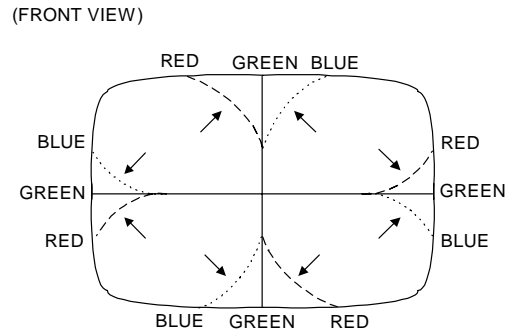

Fig.2

[Adjustment for the models equipped with differential coil.]

- If the lines are not aligned, as shown in Fig. 4, correct them with the differential coil attached to the deflection yoke.

(FRONT VIEW)

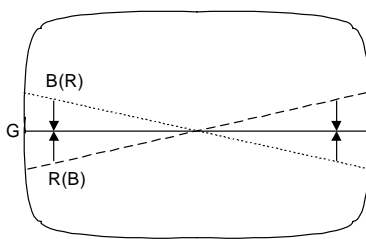

Fig.4

(FRONT VIEW)

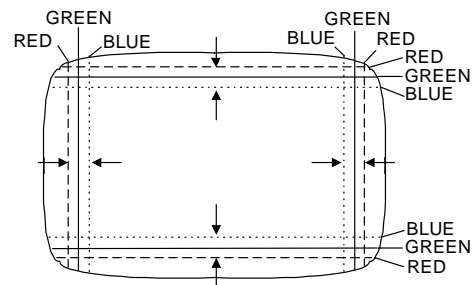

Fig.3

SELF CHECK FUNCTIONS

1. Outline

This model has self check functions given below. When a malfunction has been detected, the POWER is turned off and the LED flashes to inform of the failure . The malfunction is detected by the signal input state of the control line connected to the microcomputer.

2. Self check items

Check item	Details of detection	Method of detection	State of malfunction
Over-current protection (HAZARD)	Operation of B1 protector circuit.	The microcomputer detects at 1 second intervals. If NG is detected for more than 1 ms, a malfunction is interpreted.	When a malfunction has been detected, the POWER is turned off. While the POWER is being turned off , the power key of the remote controller is not operational until the power code is taken out and put in again.

3. Self check indicating function

The self-check function begins detection about 5 seconds after power is supplied.

In the event a malfunction is detected, the power is cut off immediately.

At this time, the ON-TIMER LED flashes to inform of the malfunction.

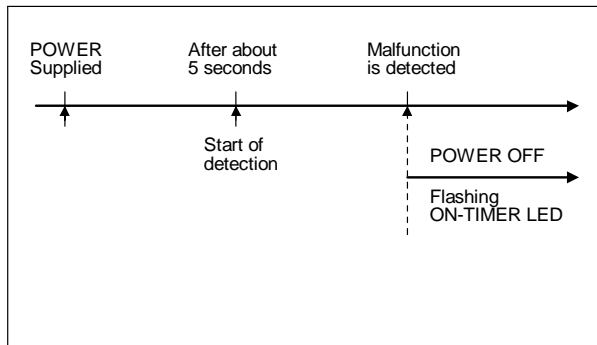

[ON-TIMER LED indication]

The ON-TIMER LED flashes at 0.5 seconds intervals.

AV-N29301
AV-N34301