

JVC

SERVICE MANUAL

COLOR TELEVISION

BASIC CHASSIS

GA

AV-T2922/AR

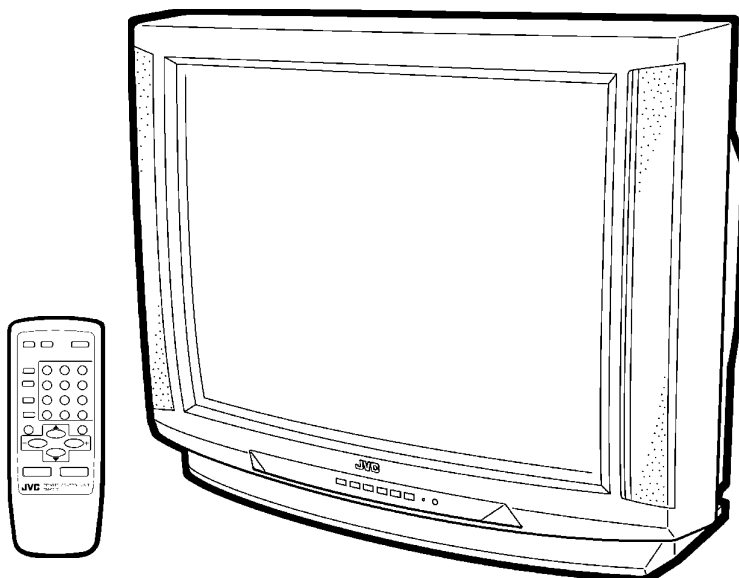

CONTENTS

- SPECIFICATIONS 2
- SAFETY PRECAUTIONS 3
- FEATURES 4
- FUNCTIONS 5
- SPECIFIC SERVICE INSTRUCTIONS 6
- SERVICE ADJUSTMENTS 11
- ★ STANDARD CIRCUIT DIAGRAM (APPENDIX) 2-1
- PARTS LIST 31

SPECIFICATIONS

Items	Content
Dimensions (W×H×D)	29-5/8" × 23-1/4" × 20-5/8" / 75.2cm × 59.0cm × 52.2cm
Mass	90.9lbs / 41.3kg
TV System and Color system	
TVRF System	CCIR(M), CCT R(N)
Color System	PAL-M / PAL-N / NTSC
Sound System	BTSC (Multi Channel Sound)
Picture Tube	29" (74cm) measured diagonally, Full Square
High Voltage	29kV ±1.3kV (at zero beam current)
TV Receiving Frequency	
VL Band	(02~06) 55.25MHz~83.25MHz
VH Band	(07~13) 175.25MHz~211.25MHz
UHF Band	(14~69) 471.25MHz~801.25MHz
CATV Receiving Frequency	
Low Band	(02~06)
High Band	(07~13)
Mid Band	(14~22)
Super Band	(23~36)
Hyper Band	(37~64)
Ultra Band	(65~94, 100~125)
Sub Mid Band	(01, 96~99)
	(55.25MHz~799.25MHz)
Intermediate Frequency	
Video IF Carrier	PICTURE : 45.75MHz
CHROMA : 42.17MHz	
Sound IF Carrier	41.25MHz (4.5MHz)
Color Sub Carrier	
PAL-M	3.57561149MHz
PAL-N	3.58205625MHz
NT SC	3.579545MHz
Power Input	
Operating Voltage	90V~260V AC, 50Hz/60Hz
Rated Voltage	120V~240V AC, 50Hz/60Hz
Power Consumption	115W(max), 85W(avg.)
Speaker	2" × 4-3/4" / 5 × 12cm Oval type × 2
Audio Power Output	5W+5W
Input / Output terminals	
Input 1, 2 (V, L/R)	Video : 1Vp-p, 75 Ω (RCA pin jack) Audio : 500mVrms (-4dBs), High Impedance (RCA pin jack)
Variable Audio Output	More than 0 ~ 1550mVrms (+6dBs) Low Impedance (400Hz when modulated 100%) (RCA pin jack)
Antenna terminal	75 Ω (VHF/UHF) Terminal, F-Type Connector
Remote control unit	RM-C363-1H (AA/R03/UM-4 dry cell battery × 2)

Design & specifications are subject to change without notice.

SAFETY PRECAUTIONS

- The design of this product contains special hardware, many circuits and components specially for safety purposes. For continued protection, no changes should be made to the original design unless authorized in writing by the manufacturer. Replacement parts must be identical to those used in the original circuits. Service should be performed by qualified personnel only.
- Alterations of the design or circuitry of the products should not be made. Any design alterations or additions will void the manufacturer's warranty and will further relieve the manufacturer of responsibility for personal injury or property damage resulting therefrom.
- Many electrical and mechanical parts in the products have special safety-related characteristics. These characteristics are often not evident from visual inspection nor can the protection afforded by them necessarily be obtained by using replacement components rated for higher voltage, wattage, etc. Replacement parts which have these special safety characteristics are identified in the parts list of Service manual. **Electrical components having such features are identified by shading on the schematics and by (Δ) on the parts list in Service manual.** The use of a substitute replacement which does not have the same safety characteristics as the recommended replacement part shown in the parts list of Service manual may cause shock, fire, or other hazards.
- Don't short between the LIVE side ground and ISOLATED (NEUTRAL) side ground or EARTH side ground when repairing.**
Some model's power circuit is partly different in the GND. The difference of the GND is shown by the LIVE : (⊥) side GND, the ISOLATED(NEUTRAL) : (≡) side GND and EARTH : (⊕) side GND. Don't short between the LIVE side GND and ISOLATED(NEUTRAL) side GND or EARTH side GND and never measure with a measuring apparatus (oscilloscope etc.) the LIVE side GND and ISOLATED(NEUTRAL) side GND or EARTH side GND at the same time.
If above note will not be kept, a fuse or any parts will be broken.
- If any repair has been made to the chassis, it is recommended that the B1 setting should be checked or adjusted (See ADJUSTMENT OF B1 POWER SUPPLY).
- The high voltage applied to the picture tube must conform with that specified in Service manual. Excessive high voltage can cause an increase in X-Ray emission, arcing and possible component damage, therefore operation under excessive high voltage conditions should be kept to a minimum, or should be prevented. If severe arcing occurs, remove the AC power immediately and determine the cause by visual inspection (incorrect installation, cracked or melted high voltage harness, poor soldering, etc.). To maintain the proper minimum level of soft X-Ray emission, components in the high voltage circuitry including the picture tube must be the exact replacements or alternatives approved by the manufacturer of the complete product.
- Do not check high voltage by drawing an arc. Use a high voltage meter or a high voltage probe with a VTVM. Discharge the picture tube before attempting meter connection, by connecting a clip lead to the ground frame and connecting the other end of the lead through a 10KΩ 2W resistor to the anode button.
- When service is required, observe the original lead dress. Extra precaution should be given to assure correct lead dress in the high voltage circuit area. Where a short circuit has occurred, those components that indicate evidence of overheating should be replaced. Always use the manufacturer's replacement components.
- Isolation Check (Safety for Electrical Shock Hazard)**
After re-assembling the product, always perform an isolation check on the exposed metal parts of the cabinet (antenna terminals, video/audio input and output terminals, Control knobs, metal cabinet, screw heads, earphone jack, control shafts, etc.) to be sure the product is safe to operate without danger of electrical shock.
 - Dielectric Strength Test**
The isolation between the AC primary circuit and all metal parts exposed to the user, particularly any exposed metal part having a return path to the chassis should withstand a voltage of 3000V AC (r.m.s.) for a period of one second.
(... Withstand a voltage of 1100V AC (r.m.s.) to an appliance rated up to 120V, and 3000V AC (r.m.s.) to an appliance rated 200V or more, for a period of one second.)
This method of test requires a test equipment not generally found in the service trade.
 - Leakage Current Check**
Plug the AC line cord directly into the AC outlet (do not use a line isolation transformer during this check.). Using a "Leakage Current Tester", measure the leakage current from each exposed metal part of the cabinet, particularly any exposed metal part having a return path to the chassis, to a known good earth ground (water pipe, etc.). Any leakage current must not exceed 0.5mA AC (r.m.s.).
However, in tropical area, this must not exceed 0.2mA AC (r.m.s.).
 - Alternate Check Method**
Plug the AC line cord directly into the AC outlet (do not use a line isolation transformer during this check.). Use an AC voltmeter having 1000 ohms per volt or more sensitivity in the following manner. Connect a 1500Ω 10W resistor paralleled by a 0.15μF AC-type capacitor between an exposed metal part and a known good earth ground (water pipe, etc.). Measure the AC voltage across the resistor with the AC voltmeter. Move the resistor connection to each exposed metal part, particularly any exposed metal part having a return path to the chassis, and measure the AC voltage across the resistor. Now, reverse the plug in the AC outlet and repeat each measurement. Any voltage measured must not exceed 0.75V AC (r.m.s.). This corresponds to 0.5mA AC (r.m.s.).
However, in tropical area, this must not exceed 0.3V AC (r.m.s.). This corresponds to 0.2mA AC (r.m.s.).

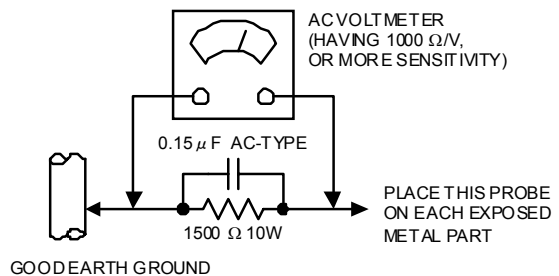

FEATURES

- The stable image processing circuit which is already acknowledged enables powerful image expression by the 29 inch big screen.
- Multifunctional remote control permits picture adjustment.
- With AUDIO / VIDEO input terminal.
- Variable audio output terminal.
- Adoption of the VIDEO STATUS function.
- Adoption of the SLEEP TIMER function.
- With 75Ω V/U in common (F-Type) antenna terminal.
- Wide range voltage (120V~240V) AC power input.
- I²C bus control utilizes single chip ICs.
- Built-in HYPER SURROUND system.
- CLOSED CAPTION broadcasts can be viewed.

MICRO COMPUTER PORT ASSIGNMENT (IC701)

PORT NUMBER	PORT FUNCTION	PORT NUMBER	PORT FUNCTION
1	H SYNC	27	Vcc
2	V SYNC	28	OSC1
3	RF AFC	29	OSC2
4	REMOCON	30	RESET
5	NECK	31	POWER ON/OFF
6	SD	32	ENABLE
7	T ON/OFF	33	CLOCK
8	KEY2	34	DATA
9	KEY1	35	LOCK
10	SP ON/OFF	36	SDA2
11	NC	37	SDA1
12	NC	38	SCL2
13	NC	39	SCL1
14	AUDIO MUTE	40	Ym
15	I2C H/S	41	BUS FREE
16	NC	42	NC
17	NC	43	SELECT1
18	A Vcc	44	SELECT2
19	HLF	45	AGC MUTE
20	RVCO	46	AGC ADJUST
21	V HOLD	47	TV / EXT
22	Composite VIDEO IN	48	X-RAY / OCP
23	CN Vss	49	Ys
24	X IN	50	B
25	X OUT	51	G
26	Vss	52	R

FUNCTIONS

FRONT CONTROL KEYS

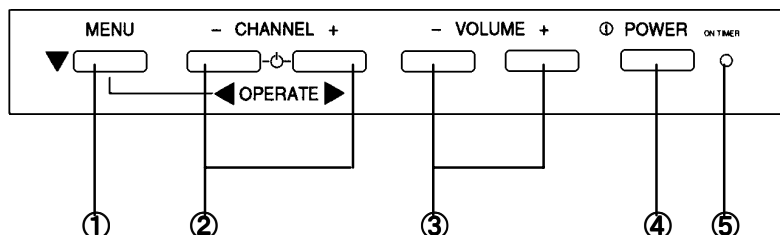

- ① MENU / OPERATE ▼ key
 - ② CHANNEL — /+ or OPERATE ◀ / ▶ keys
 - ③ VOLUME — /+ keys
 - ④ POWER button
 - ⑤ LED (indicator)
- Red ···· Power indication
Green ·· On Timer indication

REMOTE CONTROL UNIT (RM-C363)

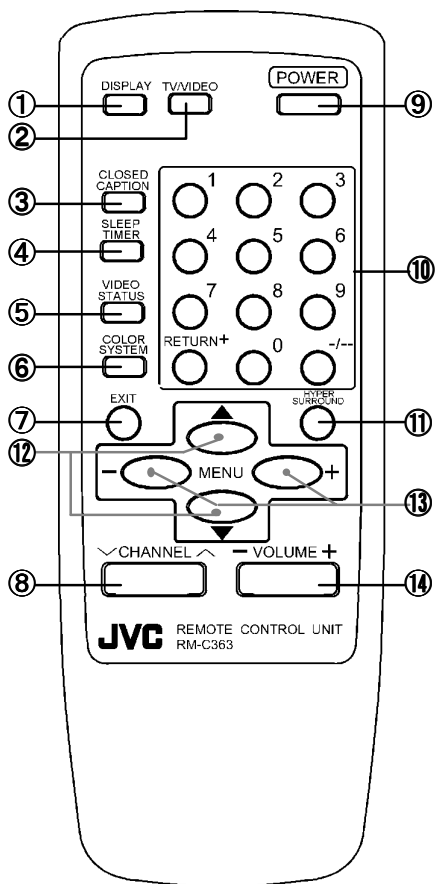

JVC REMOTE CONTROL UNIT RM-C363

REAR TERMINAL

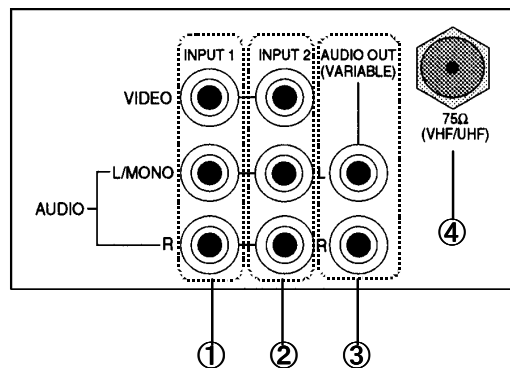

- ① INPUT 1 (V, L/R) terminal
- ② INPUT 2 (V, L/R) terminal
- ③ VARIABLE AUDIO OUT (L/R) terminal
- ④ Aerial socket (F-type connector)

- ① DISPLAY key
- ② TV / VIDEO key
- ③ CLOSED CAPTION key
- ④ SLEEP TIMER key
- ⑤ VIDEO STATUS key
- ⑥ COLOR SYSTEM key
- ⑦ EXIT key
- ⑧ CHANNEL ▲/▼ key
- ⑨ POWER button
- ⑩ CHANNEL NUMBER key
- ⑪ HYPER SURROUND key
- ⑫ MENU ▲/▼ key
- ⑬ MENU - / + key
- ⑭ VOLUME -/+ key

SPECIFIC SERVICE INSTRUCTIONS

DISASSEMBLY PROCEDURE

REMOVING THE REAR COVER

1. Unplug the power plug from AC outlet.
2. As shown in Fig.1, remove the **11** screws marked **(A)** and **2** screws marked **(B)**.

Note:

When reinstalling the rear cover, carefully push it inward after inserting the chassis into the rear cover groove.

REMOVING THE CHASSIS

- After removing the rear cover.
1. Slightly raise the both sides of the chassis by hand and remove the 2 claws under the both sides of the chassis from the front cabinet.
 2. Draw the chassis backward along the chassis rail in the arrow direction marked **(C)** as shown in the Fig. 1.
(If necessary, remove the wire clamp, connectors etc.)

Note:

When conducting a check with power supplied, be sure to confirm that the CRT earth wire is certainly connected.

REMOVING THE SPEAKER

- After removing the rear cover and chassis.
1. As shown in Fig.1, remove the **4** screws marked **(D)**.
 2. Follow the same steps when removing the other hand speaker.

CHECKING THE MAIN PW BOARD

To check the backside of the MAIN PW Board.

- 1) Pull out the chassis. (Refer to REMOVING THE CHASSIS).
- 2) Erect the chassis vertically so that you can easily check the backside of the MAIN PW Board.

[CAUTION]

- When erecting the chassis, be careful so that there will be no contacting with other PWB.
- Before turning on power, make sure that the CRT earth wire and other connectors are properly connected.

WIRE CLAMPING AND CABLE TYING

1. Be sure to clamp the wire.
2. Never remove the cable tie used for tying the wires together. Should it be inadvertently removed, be sure to tie the wires with a new cable tie.

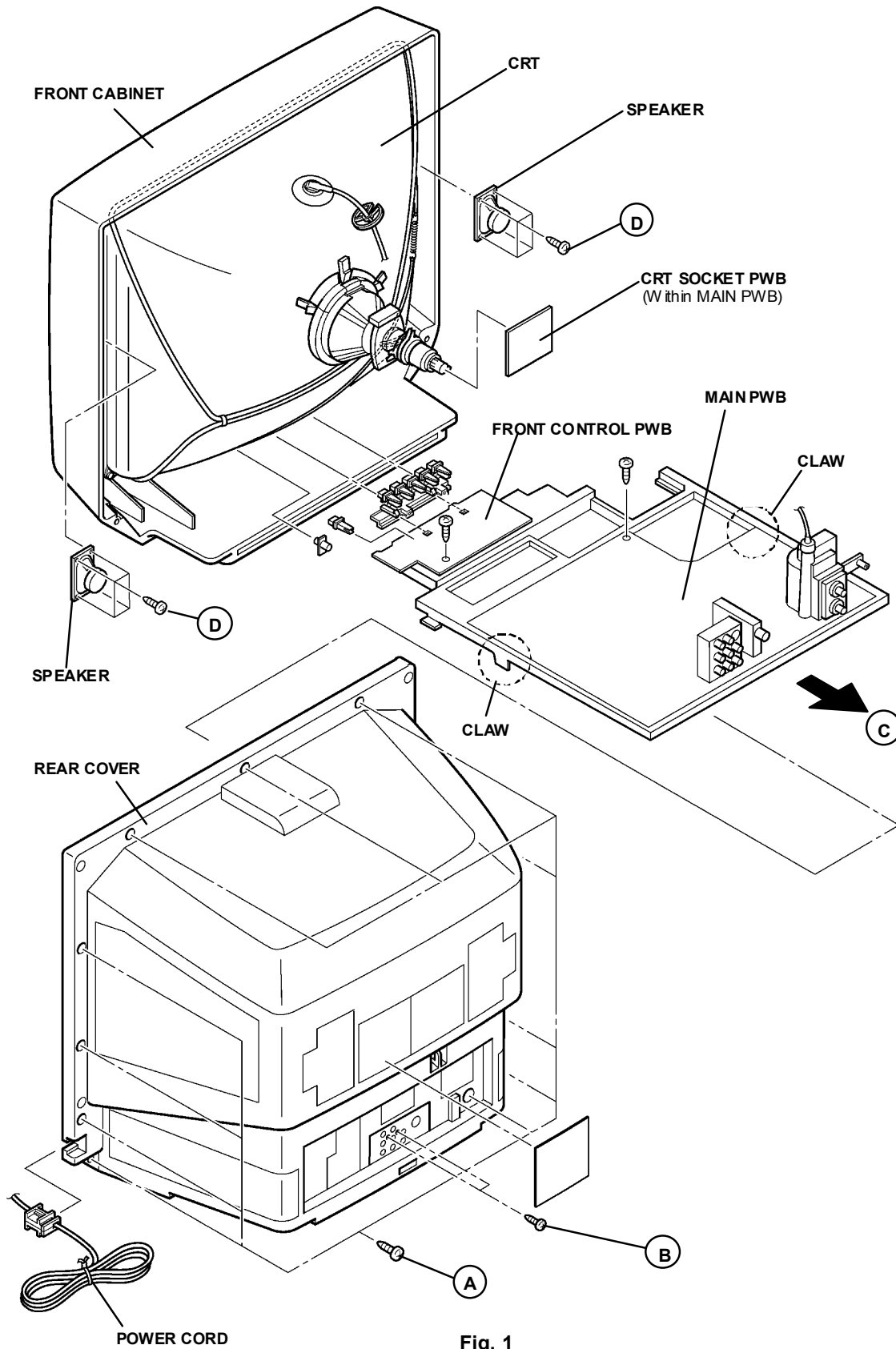

Fig. 1

MEMORY IC REPLACEMENT

1. Memory IC

This model uses a memory IC.

The memory IC stores data for proper operation of video/chroma and deflection circuits.

When replacing, be sure to use the IC containing initial setting data.

2. Memory IC replacement procedure

PROCEDURE	
(1) Power off	Switch off the power and disconnect the power plug from the outlet.
(2) Replace the memory IC.	Be sure to use the memory IC written with the initial setting values.
(3) Power on	Connect the power plug to the outlet and switch on the power.
(4) System constant check and setting It must not adjust without signal.	<ol style="list-style-type: none"> 1) Simultaneously press the DISPLAY key and VIDEO STATUS key of the remote control unit. 2) The SERVICE MENU screen is displayed as shown in Fig.1. 3) While the SERVICE MENU is displayed, again simultaneously press the DISPLAY and VIDEO STATUS keys to display the SYSTEM CONSTANT screen as shown in Fig. 2. 4) Refer to the SYSTEM CONSTANT table and check the setting items. Where these differ, select the setting item with the MENU ▲ / ▼ keys and adjust the setting with the MENU — / + keys. (The letters of the selected item are displayed in yellow.) 5) When adjustment has completed, press the MENU — / + key to store the setting value. 6) Press the EXIT key twice to return to the normal screen.
(5) Receiving channel setting	Refer to the OPERATING INSTRUCTIONS (USER'S GUIDE) and set the receive channels (Channels Preset) as described.
(6) User settings	<p>Check the user setting items according to the Table 2 given page later.</p> <p>Where these do not agree, refer to the OPERATING INSTRUCTIONS (USER'S GUIDE) and set the items as described.</p>
(7) SERVICE MENU setting	Verify what to set in the SERVICE MENU, and set whatever is necessary. (Fig. 1) refer to the SERVICE ADJUSTMENT for setting.

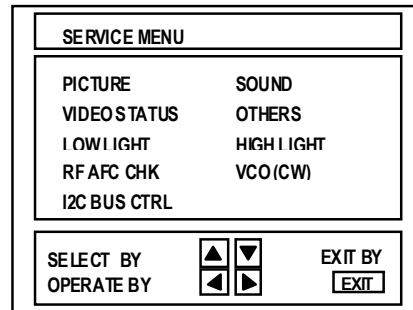

Fig.1

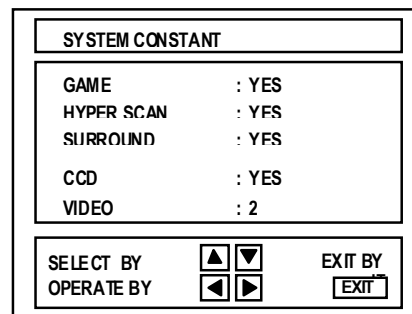
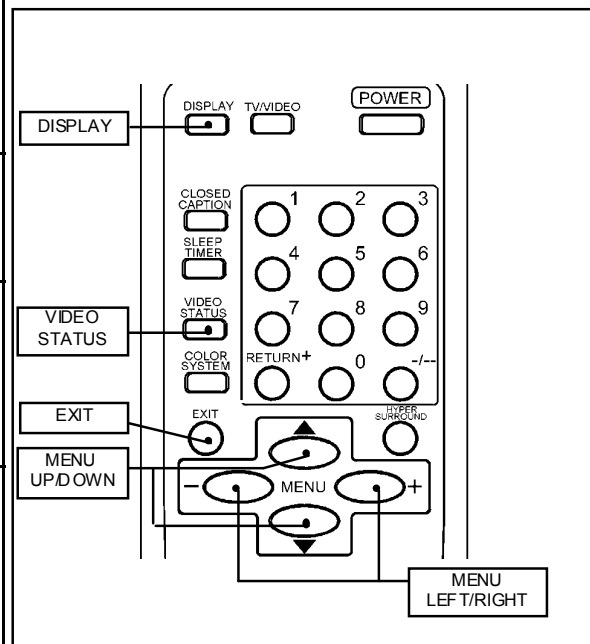
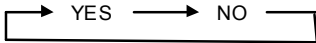
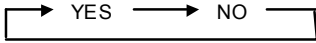
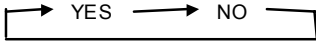
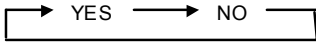
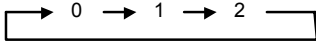

Fig.2



VALUES OF SYSTEM CONSTANT (TABLE1)

Setting item	Setting content	Setting value
GAME		YES
HYPERSCAN		YES
SURROUND		YES
CCD		YES
VIDEO		2

VALUES OF USER SETTING ITEMS (TABLE2)

Setting item	Setting value
Settings of switches on front panel and remote control unit	
MAIN POWER	OFF
SUB POWER	ON
CHANNEL	CH 02
CHANNEL PRESET	Refer to OPERATING INSTRUCTIONS
VOLUME	10
TV/VIDEO	TV
DISPLAY	OFF
SLEEP TIMER	0
VIDEO STATUS	ESTANDAR
CLOSED CAPTION	NO (CC1/T1)
HYPER SURROUND	NO
Settings of MENU screen	
TINTE	ESTANDER
COLOR	ESTANDER
CONTRASTE	ESTANDER
BRILLO	ESTANDER
DETALLE	ESTANDER
GRAVES	CENTER
AGUDOS	CENTER
BALANCE	CENTER
MTS	ESTEREO
ALTAVOCES	SI
AJUSTE DEL RELOJ	Unnecessary to set
TEMPORIZADOR	NO
LISTA DE CANALES	Unnecessary to set
ADJUSTECÓDIGO DE ACCESO	Unnecessary to set
PROGRAMACIÓN AUTOMÁTICA	Unnecessary to set
MODE	TV
PANTALLA AZUL	NO
SUBTÍTULOS OCULTOS	SUBTÍTULOS : CC1 TEXT0: T1
IDIOMA	ESP.

REPLACEMENT OF CHIP COMPONENT

CAUTIONS

1. Avoid heating for more than 3 seconds.
2. Do not rub the electrodes and the resist parts of the pattern.
3. When removing a chip part, melt the solder adequately.
4. Do not reuse a chip part after removing it.

SOLDERING IRON

1. Use a high insulation soldering iron with a thin pointed end of it.
2. A 30w soldering iron is recommended for easily removing parts.

REPLACEMENT STEPS

1. How to remove the Chip parts

Resistors, capacitors, etc

- (1) As shown in the figure, push the part with tweezers and alternately melt the solder at each end.

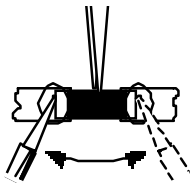

- (2) Shift with tweezers and remove the chip part.

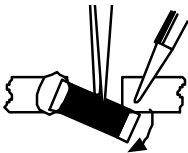

Transistors, diodes, variable resistors, etc

- (1) Apply extra solder to each lead.



- (2) As shown in the figure, push the part with tweezers and alternately melt the solder at each lead. Shift and remove the chip part.

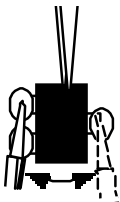

Note : After removing the part, remove remaining solder from the pattern.

2. How to install Chip parts

Resistors, capacitors, etc

- (1) Apply solder to the pattern as indicated in the figure.

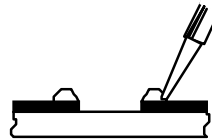

- (2) Grasp the chip part with tweezers and place it on the solder. Then heat and melt the solder at both ends of the chip part.

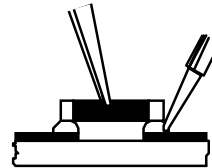

Transistors, diodes, variable resistors, etc

- (1) Apply solder to the pattern as indicated in the figure.
- (2) Grasp the chip part with tweezers and place it on the solder.
- (3) First solder lead **A** as indicated in the figure.

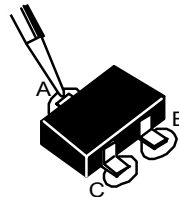

- (4) Then solder leads **B** and **C**.

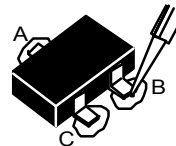

SERVICE ADJUSTMENT

BEFORE STARTING SERVICE ADJUSTMENT

1. There are 2 way of adjusting this TV: One is with the REMOTE CONTROL UNIT and the other is the conventional method using adjustment parts and components.
2. The adjustment with the REMOTE CONTROL UNIT is made on the basis of the initial setting values. The setting values which adjust the screen to its optimum condition may differ from the initial setting values.
3. Make sure that connection is correctly made to AC power source.
4. Turn on the power of the set and equipment before use, and start the adjustment procedures after waiting at least 30 minutes.
5. Unless otherwise specified, prepare the most suitable reception or input signal for adjustment.
6. Never touch any adjustment parts, which are not specified in the list for this adjustment VRs, transforms, condensers, etc.
7. Preparation for adjustment
Unless otherwise specified in the adjustment instructions, preset the following functions with the REMOTE CONTROL UNIT.

User menu preset value

MENU ITEM	PRESET VALUE
VIDEO STATUS	ESTANDAR
TINTE, COLOR, CONTRASTE, BRILLO, DETALLE	ESTANDAR
GRAVES, AUGDOS, BALANCE	CENTER
HYPERSURROUND	NO

MEASURING INSTRUMENT AND FIXTURES

1. DC voltmeter (or digital voltmeter)
2. Oscilloscope
3. Signal generator (Pattern generator) [PAL-M / PAL-N / NTSC]
4. Remote control unit
5. TV audio multiplex signal generator
6. Frequency counter

ADJUSTMENT ITEMS

BASIC ADJUSTMENT

- Check of B1 power supply
- IF VCO adjustment
- FOCUS adjustment
- RF AGC adjustment

DEFLECTION CIRCUIT ADJUSTMENT

- V. HEIGHT
- V. POSITION
- V. LINEARITY
- V S CORRECTION
- H. POSITION

VIDEO / CHROMA CIRCUIT ADJUSTMENT

- WHITE BALANCE ~LOW LIGHT~
- WHITE BALANCE ~HIGH LIGHT~
- SUB BRIGHT
- SUB CONTRAST
- SUB COLOR
- SUB TINT

MTS CIRCUIT ADJUSTMENT

- INPUT LEVEL
- STEREO VCO
- SAP VCO
- FILTER
- SEPARATION

ADJUSTMENT LOCATIONS

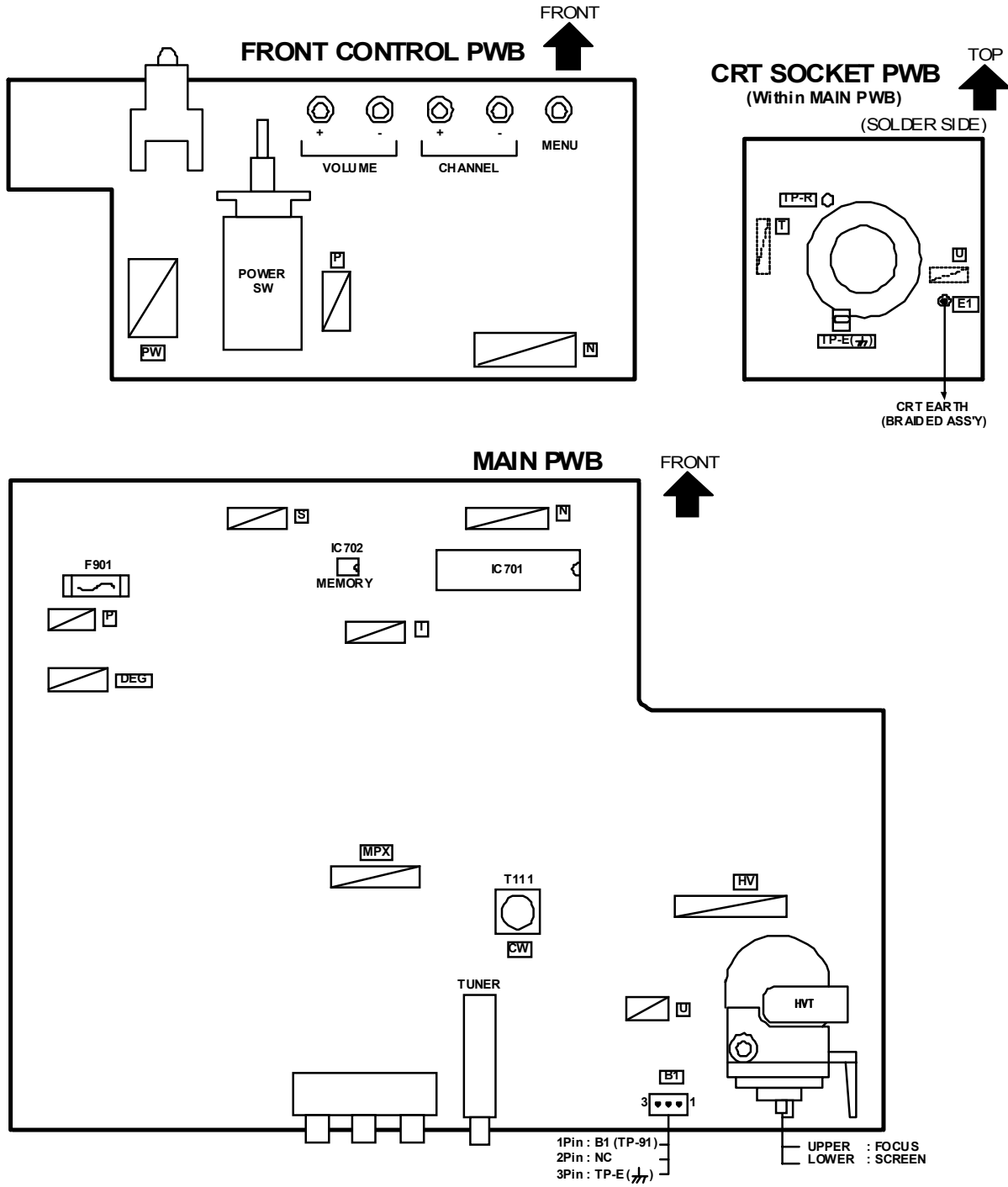

BASIC OPERATION SERVICE MENU

1. TOOL OF SERVICE MENU OPERATION

Operate the SERVICE MENU with the REMOTE CONTROL UNIT.

2. SERVICE MENU ITEMS

With the SERVICE MENU, various settings (adjustments) can be made, and they are broadly classified in the following items of adjustments.

- (1) **PICTURE** This mode adjusts the VIDEO / CHROMA and DEFLECTION circuits.
- (2) **SOUND** This mode adjusts the AUDIO circuits.
- (3) **VIDEO STATUS** This mode adjusts the THEATER and GAME mode.
- (4) **OTHERS** This mode adjusts the OTHERS mode.
- (5) **LOW LIGHT** This mode adjusts the white balance (low light) mode.
- (6) **HIGH LIGHT** This mode adjusts the white balance (high light) mode.
- (7) **RF AFC CHK** This mode adjusts the IF VCO mode. **[Do not adjust]**
- (8) **VCO(CW)** This mode adjusts the IF VCO mode.
- (9) **I²C BUS CTRL** This mode is used when necessary to adjust the on/off of the I²C bus control. **[Do not adjust. Fixed on]**

3. BASIC OPERATION OF SERVICE MENU

(1) How to enter SERVICE MENU

Press the **DISPLAY** key and the **VIDEO STATUS** key of the REMOTE CONTROL UNIT simultaneously, and the SERVICE MENU screen will be displayed (Fig. 1).

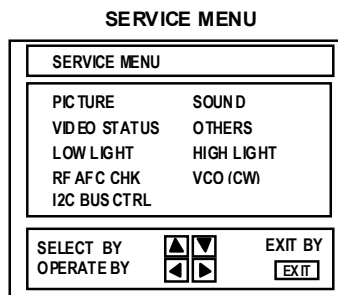
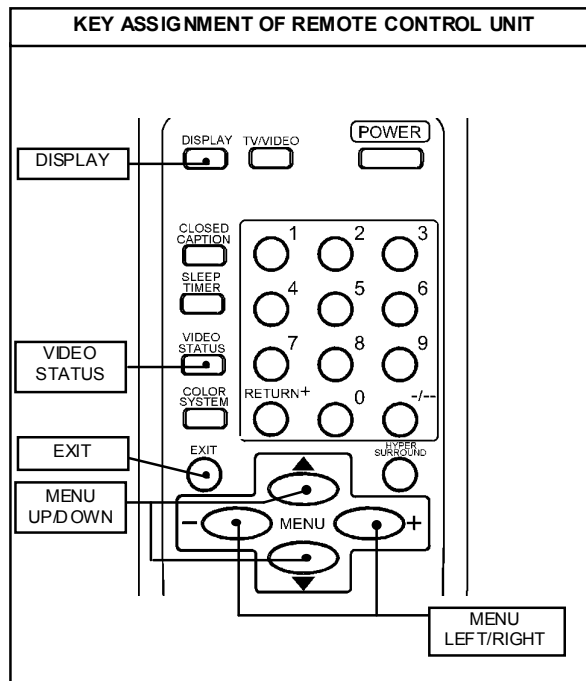

Fig.1

(2) Selection of SUB MENU SCREEN

In SERVICE MENU, press the **MENU ▲/▼** key to select any of the following items. (The letters of the selected items are displayed in yellow)

- PICTURE
- SOUND
- VIDEO STATUS
- OTHERS
- LOW LIGHT
- HIGH LIGHT
- RF AFC CHK
- VCO(CW)
- I²C BUS CTRL



(3) Method of Setting

- 1) **MENU** ▲ / ▼ key
Select the setting item.
- 2) **MENU** — / + key
Setting the setting value of the setting item.
When change the values, automatically stored in the memory.
- 3) **EXIT** key
Return to the previous screen.

NOTE

In PICTURE MODE, while the color of letters displayed yellow, you can adjust the values. If letters displayed red, you cannot adjust.

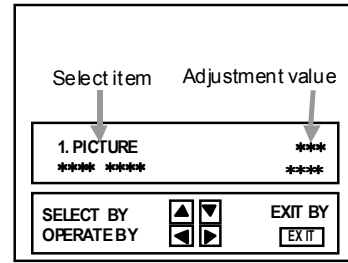

PICTURE MODE

(4) Release of SERVICE MENU

After completing the adjustment, return to the main SERVICE MENU by pressing the **EXIT** key. Then again press the **EXIT** key, return to the normal screen.

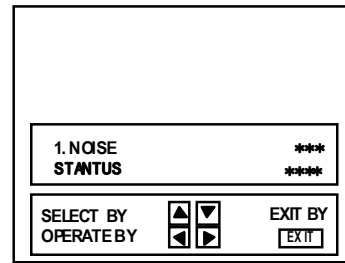

SOUND MODE

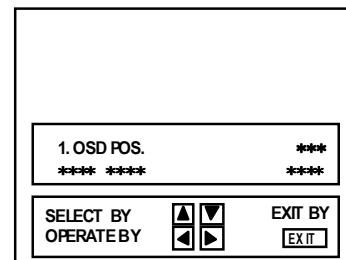

OTHERS MODE

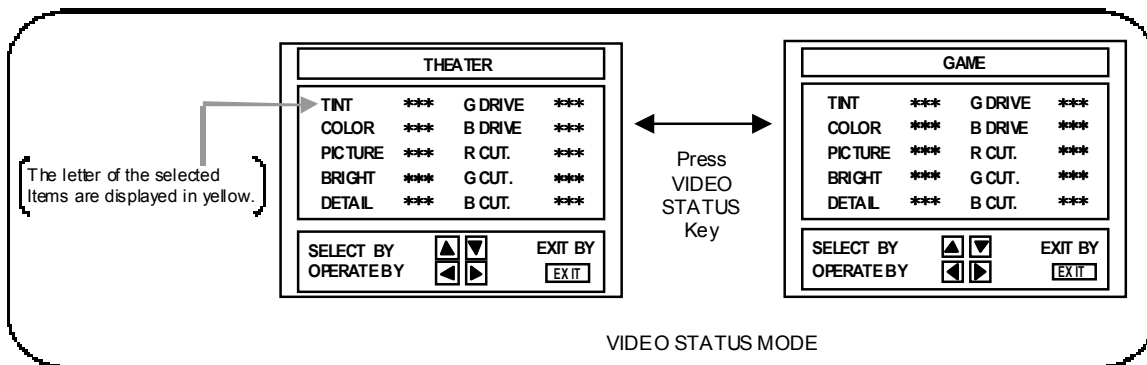

VIDEO STATUS MODE

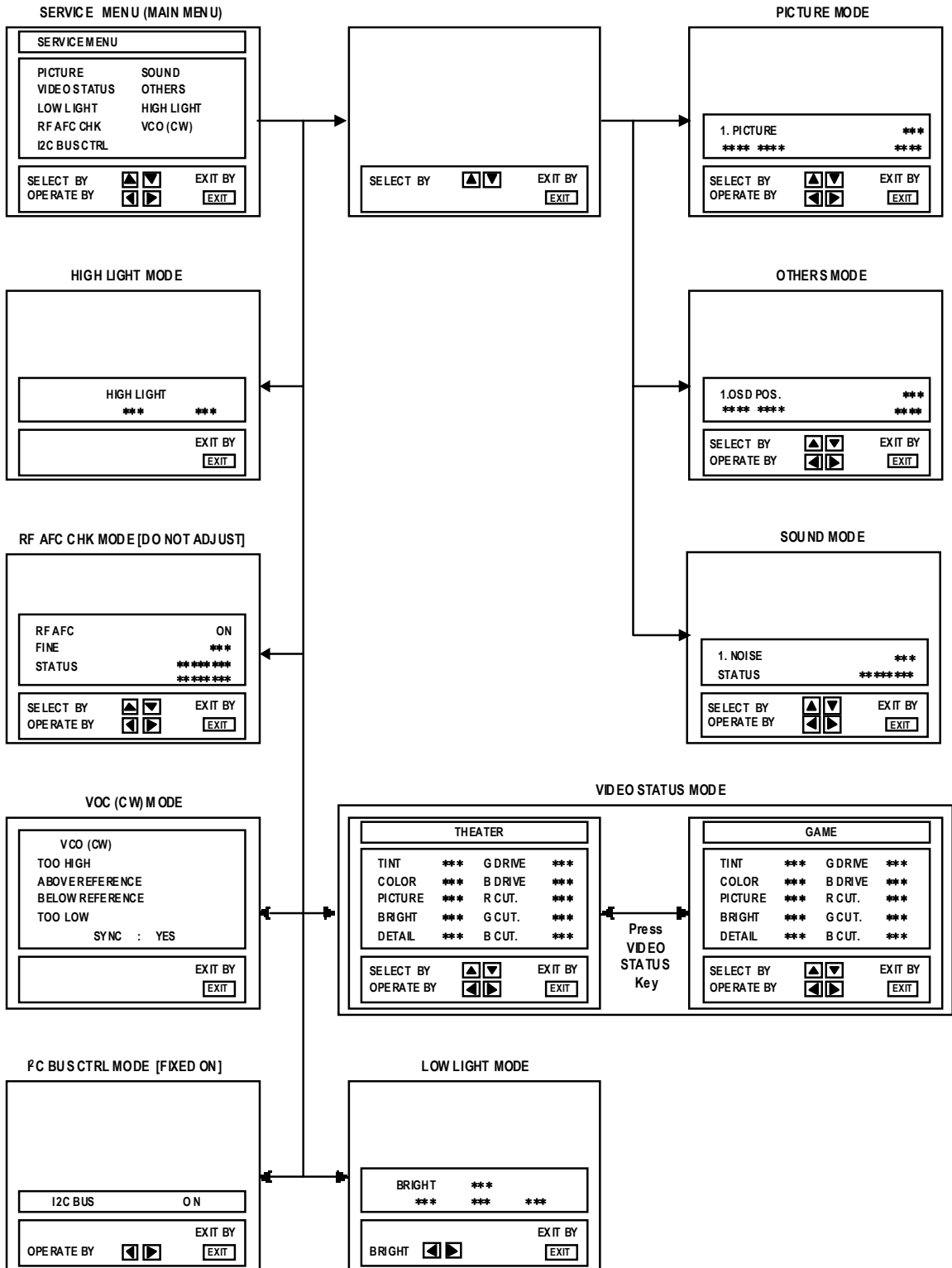

INITIAL SETTING VALUE OF SERVICE MENU

- Adjustment of the SERVICE MENU is made on the basis of the initial setting values. However, the new setting values which set the screen in its optimum condition may differ from the initial setting.
- Do not change the initial setting values of the adjustment items not listed in "ADJUSTMENT" pages.

PICTURE MODE

The four setting items in the video mode No.8 EXT PIC., No.9 EXT BRI., No.10 EXT COL., and No.11 EXT TINT are linked to the items in the TV MODE No.1 PICTURE, No.2 BRIGHT, No.5 COL.NTSC and No.6 TINT, respectively. When the setting items in the TV mode are adjusted, the values in the setting items in the video mode are revised automatically to the same values in the TV mode. (The initial setting values given in () are off-set values.)

When the four items (No.8, 9, 10 and 11) are adjusted in the video mode, the setting values in each item are revised independently.

No.	Setting (Adjustment) item	Variable range	Initial setting value
1.	PICTURE	0~127	60
2.	BRIGHT	0~127	64
3.	COL. PALM	0~127	80
4.	COL. PALN	0~127	80
5.	COL. NTSC	0~127	95
6.	TINT	0~127	65
7.	TV DTL	0~63	33
8.	EXT PIC.	±25	(0)
9.	EXT BRI.	±25	(0)
10.	EXT COL.	±25	(+4)
11.	EXT TINT	±25	(+3)
12.	EXT DTL	0~63	30
13.	P/N KILL	0 / 1	0
14.	Y S CONT	0~31	31
15.	TV Y-DL	0~4	1
16.	EXT Y-DL	0~4	1
17.	WPL SW	0 / 1	0
18.	Y GAMMA	0 / 1	0
19.	P/N G P.	0 / 1	0
20.	COL. L SW	0 / 1	1
21.	COL. LMT.	0~3	1
22.	PN C. ATT	0~3	1
23.	OFST. SW	0 / 1	0
24.	OFST. B-Y	0~15	8
25.	OFST. R-Y	0~15	8
26.	C-TOF SW	0 / 1	1
27.	TV T FO	0~3	1
28.	TV T Q	0~3	0
29.	EXT T FO	0~3	0
30.	EXT T Q	0~3	0
31.	C-TRAP	0 / 1	0
32.	C-TR. FO	0~3	2
33.	C-TRAP Q	0~3	1
34.	FIX B/W	0 / 1	0
35.	APAP. FO	0~3	2
36.	DC TRAN.	0~7	4
37.	B. ST. SW	0 / 1	0
38.	B. ST. PO.	0~7	0
39.	ABL GAIN	0~7	4
40.	ABL PO.	0~7	0
41.	HALF T.	0~2	1
42.	DRV G SW	0 / 1	0
43.	NT. COMB	0 / 1	1
44.	COIN DET	0~3	3
45.	NOISE L.	0~3	3
46.	VCD MODE	0 / 1	0
47.	V AGC SP	0 / 1	0
48.	H POS. 50	0~31	6
49.	H BLK. 50	0~7	0
50.	V POS. 50	0~7	2

PICTURE MODE

No.	Setting (Adjustment) item	Variable range	Initial setting value
51.	V SIZE50	0~127	71
52.	V S CR50	0~127	83
53.	V LIN. 50	0~31	4
54.	H POS. 60	0~31	10
55.	H BLK. 60	0~7	0
56.	V POS. 60	0~7	0
57.	V SIZE60	0~127	72
58.	V S CR60	0~127	99
59.	V LIN. 60	0~31	3
60.	RF AGC	0~255	160

SOUND MODE

No.	Setting (Adjustment) item	Variable range	Initial setting value
1.	NOISE	0/ 1	1
2.	IN LEVEL	0~63	50
3.	FH MON.	0/ 1	0
4.	ST VCO	0~63	25
5.	PILOT	0/ 1	0
6.	FILTER	0~63	30
7.	LOW SEP.	0~63	22
8.	HI SEP.	0~63	23
9.	5FH MON.	0/ 1	0
10.	SAP VCO	0~63	26
11.	IN GAIN	0/ 1	0
12.	FIL. OFF.	0~10	0

VIDEO STATUS MODE

Setting (Adjustment) item	Variable range	Initial setting value	
		THEATER	GAME
TINT	±20	0	0
COLOR	±20	-3	-3
PICTURE	-30~+20	-10	-10
BRIGHT	±20	0	0
DETAIL	±15	0	-5
G DRIVE	-99~+50	-22	0
B DRIVE	-99~+50	-54	0
R CUT.	±10	0	0
G CUT.	±10	0	0
B CUT.	±10	0	0

OTHERS MODE

No.	Setting (Adjustment) item	Variable range	Initial setting value
1.	OSD POS.	0~31	7
2.	LOCK DET	0 / 1	0
3.	SD SEL.	0~2	0
4.	H-CK SW	0 / 1	0

LOW LIGHT MODE

Setting (Adjustment) item	Variable range	Initial setting value
R CUTOFF	0~255	20
G CUTOFF	0~255	20
B CUTOFF	0~255	20

HIGH LIGHT MODE

Setting (Adjustment) item	Variable range	Initial setting value
G DRIVE	0~255	128
B DRIVE	0~255	128

RF AFC CHK MODE

Setting (Adjustment) item	Variable range	Initial setting value
RF AFC	ON / OFF	ON
FINE	-77~+77	± × × DO NOT ADJUST

I²C BUS CTRL MODE

Setting (Adjustment) item	Variable range	Initial setting value
I ² C BUS	ON / OFF	[Fixed ON]

ADJUSTMENTS

BASIC ADJUSTMENT

Item	Measuring instrument	Test point	Adjustment item	Description
Check of B1 POWER SUPPLY	DC Voltmeter	TP-91 (B1 connector 1 pin) TP-E(≠) (B1 connector 3 pin)		<ol style="list-style-type: none"> 1. Receive a black and white signal (color off). (NTSC) 2. Connect the DC voltmeter to B1 connector 1 pin (TP-91) and TP-E(≠) (B1 connector 3 pin). 3. Confirm that the voltage is DC129.5V ± 2.5V.
IF VCO adjustment	Signal generator Remote control unit		CW TRANSF. (T111) VCO (CW) mode	<ul style="list-style-type: none"> • Under normal conditions, no adjustment is required. And it must not adjust without signal. <ol style="list-style-type: none"> 1. Receive the NTSC broadcast. 2. Select the VCO(CW) mode from the SERVICE MENU. 3. It checks that turn the CW TRANSF and the character of "TOO HIGH" changes to yellow. 4. Next, it checks that turn the CW TRANSF on the contrary and "TOO LOW" changes to yellow. 5. At this time, it checks that "SYNC" is "YES". 6. Turn the CW TRANSF and it is made for the character of "BELOW REFERENCE" to become yellow. Again, it checks that "SYNC" is "YES".
FOCUS adjustment	Signal generator		FOCUS VR [In HVT]	<ol style="list-style-type: none"> 1. Receive a crosshatch signal. 2. While looking at the screen, adjust FOCUS VR so that the vertical and horizontal lines will be clear and fine in a detail. 3. Make sure that the picture is in focus even when the screen gets darkened.

Item	Measuring instrument	Test point	Adjustment part	Description		
RF AGC Adjustment	Remote control unit		No.60 RF AGC	<ol style="list-style-type: none"> 1. Receive any broadcast. 2. Select "No.60 RF AGC" of the PICTURE MODE in SERVICE MENU. 3. Press the MUTING key and turn off the color. 4. With the MENU — key, get noise in the screen picture. (Zero side of setting value) 5. Press the MENU + key and stop when noise disappears from the screen. 6. Change to other channels and make sure that there is no irregularity. 7. Press the MUTING key and get color out. 		
				<table border="1" style="width: 100%; border-collapse: collapse;"> <thead> <tr> <th data-bbox="444 856 812 940">Setting Item</th> <th data-bbox="812 856 1010 940">Variable range</th> <th data-bbox="1010 856 1279 940">Initial setting value</th> </tr> </thead> <tbody> <tr> <td data-bbox="444 940 812 1050" style="text-align: center;">No.60 RF AGC</td> <td data-bbox="812 940 1010 1050" style="text-align: center;">0~255</td> <td data-bbox="1010 940 1279 1050" style="text-align: center;">160</td> </tr> </tbody> </table>	Setting Item	Variable range
Setting Item	Variable range	Initial setting value				
No.60 RF AGC	0~255	160				

DEFLECTION CIRCUIT ADJUSTMENT

The setting (adjustment) using the remote control unit is made on the basis of the initial setting values.
 The setting values which adjust the screen to the optimum condition can be different from the initial setting values.

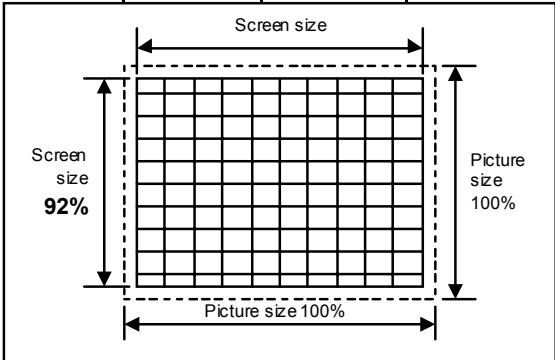
Item	Measuring instrument	Test point	Adjustment part	Description										
<p>60Hz PAL-M or NTSC signal adjustment</p> <p>V. HEIGHT V. POSITION V. LIN V. S CR adjustment</p>	<p>Signal generator</p> <p>Remote control unit</p>		<p>No.56 V POS. 60 No.57 V SIZE 60 No.58 V S CR60 No.59 V. LIN. 60</p>	<ol style="list-style-type: none"> 1. Receive a crosshatch signal.(NTSC or PAL-M) 2. Confirm that the value of PICTURE MODE "No.56 V POS. 60" is 0. 3. Confirm the initial setting value of the "No.57 V SIZE 60", No.58 V S CR60" and "No.59 V LIN. 60". 4. Adjust the vertical screen size to 92% with the PICTURE MODE "No.57 V SIZE60". 5. Adjust the PICTURE MODE "No.59 V LIN. 60" and "No.58 V S CR60" to get the best vertical linearity. <p>NOTE :</p> <ul style="list-style-type: none"> ● The PICTURE MODE "No.56 V POS. 60" is fixed on value 0. ● Bottom of screen is to be located within the 85%~95% range. <table border="1" style="width: 100%; margin-top: 10px; border-collapse: collapse;"> <thead> <tr> <th style="width: 60%;">ADJUSTMENT ITEM</th> <th style="width: 40%;">INITIAL SETTING VALUE</th> </tr> </thead> <tbody> <tr> <td>No.56 V POS. 60</td> <td>00(Fixed on)</td> </tr> <tr> <td>No.57 V SIZE 60</td> <td>72</td> </tr> <tr> <td>No.58 V S CR 60</td> <td>99</td> </tr> <tr> <td>No.59 V. LIN. 60</td> <td>03</td> </tr> </tbody> </table>	ADJUSTMENT ITEM	INITIAL SETTING VALUE	No.56 V POS. 60	00(Fixed on)	No.57 V SIZE 60	72	No.58 V S CR 60	99	No.59 V. LIN. 60	03
ADJUSTMENT ITEM	INITIAL SETTING VALUE													
No.56 V POS. 60	00(Fixed on)													
No.57 V SIZE 60	72													
No.58 V S CR 60	99													
No.59 V. LIN. 60	03													
														
<p>50Hz PAL-N signal adjustment</p> <p>V. HEIGHT V. POSITION V. LIN V. S CR adjustment</p>	<p>Signal generator</p> <p>Remote control unit</p>		<p>No.50 V POS. 50 No.51 V SIZE 50 No.52 V S CR50 No.53 V LIN. 50</p>	<ol style="list-style-type: none"> 1. Receive a crosshatch signal. (PAL-N) 2. Confirm the initial setting value of the "No.50 V POS.50", "No.51 V SIZE 50", "No.52 V S CR 50" and "No.53 V LIN.50". 3. Adjust the vertical screen size to 92% with the PICTURE MODE "No.51 V SIZE50". 4. Adjust the PICTURE MODE "No.53 V LIN.50" and "No.52 V S CR50" to get the best vertical linearity. 5. Adjust the PICTURE MODE "No.50 V POS.50" so that the vertical center comes close to the CRT vertical center as much as possible. 6. Readjust V SIZE, V LIN. and V S CR if necessary. <p>NOTE :</p> <ul style="list-style-type: none"> ● Bottom of screen is to be located within the 85%~95% range. <table border="1" style="width: 100%; margin-top: 10px; border-collapse: collapse;"> <thead> <tr> <th style="width: 60%;">ADJUSTMENT ITEM</th> <th style="width: 40%;">INITIAL SETTING VALUE</th> </tr> </thead> <tbody> <tr> <td>No.50 V POS. 50</td> <td>02</td> </tr> <tr> <td>No.51 V SIZE 50</td> <td>71</td> </tr> <tr> <td>No.52 V S CR 50</td> <td>83</td> </tr> <tr> <td>No.53 V. LIN. 50</td> <td>04</td> </tr> </tbody> </table>	ADJUSTMENT ITEM	INITIAL SETTING VALUE	No.50 V POS. 50	02	No.51 V SIZE 50	71	No.52 V S CR 50	83	No.53 V. LIN. 50	04
ADJUSTMENT ITEM	INITIAL SETTING VALUE													
No.50 V POS. 50	02													
No.51 V SIZE 50	71													
No.52 V S CR 50	83													
No.53 V. LIN. 50	04													

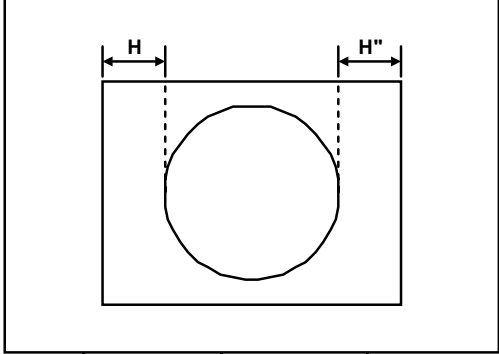
Item	Measuring instrument	Test point	Adjustment part	Description				
<p>60Hz PAL-M or NTSC signal adjustment</p> <p>H. POSITION adjustment</p>	<p>Signal generator</p> <p>Remote control unit</p>		<p>No.54 H POS.60</p>	<p>1. Receive a crosshatch signal. (NTSC or PAL-M)</p> <p>2. Select the "No.54 H POS. 60" of the PICTURE mode in SERVICE MENU.</p> <p>3. Confirm the initial setting value of the "No.54 H POS. 60".</p> <p>4. Adjust the "No.54 H POS. 60" until the screen will be horizontally centered.</p> <table border="1" data-bbox="816 688 1312 856"> <thead> <tr> <th data-bbox="816 688 1052 758">ADJUSTMENT ITEM</th> <th data-bbox="1052 688 1312 758">INITIAL SETTING VALUE</th> </tr> </thead> <tbody> <tr> <td data-bbox="816 758 1052 856">No.54 H POS. 60</td> <td data-bbox="1052 758 1312 856">10</td> </tr> </tbody> </table> 	ADJUSTMENT ITEM	INITIAL SETTING VALUE	No.54 H POS. 60	10
ADJUSTMENT ITEM	INITIAL SETTING VALUE							
No.54 H POS. 60	10							
<p>50Hz PAL-N signal adjustment</p> <p>H. POSITION adjustment</p>	<p>Signal generator</p> <p>Remote control unit</p>		<p>No.48 H POS.50</p>	<p>1. Receive a crosshatch signal. (PAL-N)</p> <p>2. Select the "No.48 H POS. 50" of the PICTURE mode in SERVICE MENU.</p> <p>3. Confirm the initial setting value of the "No.48 H POS. 50".</p> <p>4. Adjust the "No.48 H POS. 50" until the screen will be horizontally centered.</p> <table border="1" data-bbox="816 1434 1312 1602"> <thead> <tr> <th data-bbox="816 1434 1052 1503">ADJUSTMENT ITEM</th> <th data-bbox="1052 1434 1312 1503">INITIAL SETTING VALUE</th> </tr> </thead> <tbody> <tr> <td data-bbox="816 1503 1052 1602">No.48 H POS. 50</td> <td data-bbox="1052 1503 1312 1602">06</td> </tr> </tbody> </table>	ADJUSTMENT ITEM	INITIAL SETTING VALUE	No.48 H POS. 50	06
ADJUSTMENT ITEM	INITIAL SETTING VALUE							
No.48 H POS. 50	06							

VIDEO / CHROMA CIRCUIT ADJUSTMENT

The adjustment using the remote control unit is made on the basis of the initial setting values.
 The setting values which adjust the screen to the optimum condition can be different from the initial setting values.
 Do not change the initial setting values of the setting items not listed in "ADJUSTMENT".

Item	Measuring instrument	Test point	Adjustment item	Description												
WHITE BALANCE (Low Light) adjustment	Signal generator Remote control unit		BRIGHT R CUTOFF G CUTOFF B CUTOFF SCREEN VR	<ol style="list-style-type: none"> 1. Receive a black-and-white signal.(Color off) 2. Select the LOW LIGHT MODE from the SERVICE MENU. 3. Set the initial setting value of BRIGHT with the MENU — / + key of the remote control unit. 4. Set the initial setting value of R CUTOFF, G CUTOFF and B CUTOFF with the ④ to ⑨ key of the remote control unit. 5. Display a single horizontal line by pressing the ① key of the remote control unit. 6. Turn the screen VR all the way to the left. 7. Turn the screen VR gradually to the right from the left until either one of the red, blue or green colors appears faintly. 8. Use keys ④~⑨ of the remote control unit and adjust the other 2 colors which except the appeared color to where the single horizontal line appears white. 9. Turn the screen VR to where the single horizontal line glows faintly. 10. Press the ② key to release the single horizontal line. 11. Adjust the BRIGHT level to become the black component shines white slightly. 12. Confirm that whether the color ingredient of R, G or B is visible to the black component which shines white slightly. 13. When the color ingredient can be seen, two colors other than a visible color are adjusted, and it is made to look white. 14. Return the value of BRIGHT to initial setting value. 15. Press the EXIT key to exit the WHITE BALANCE MODE. 												
		<p>LOW LIGHT MODE</p>														
<p>KEY ASSIGNMENT OF REMOTE CONTROL UNIT</p>																
				<table border="1" style="width: 100%; border-collapse: collapse;"> <thead> <tr> <th style="width: 40%;">CUTOFF ADJUSTMENT</th> <th style="width: 20%;">Variable range</th> <th style="width: 40%;">Initial setting value</th> </tr> </thead> <tbody> <tr> <td style="text-align: center;">R</td> <td style="text-align: center;">0 ~255</td> <td style="text-align: center;">20</td> </tr> <tr> <td style="text-align: center;">G</td> <td style="text-align: center;">0 ~255</td> <td style="text-align: center;">20</td> </tr> <tr> <td style="text-align: center;">B</td> <td style="text-align: center;">0 ~255</td> <td style="text-align: center;">20</td> </tr> </tbody> </table>	CUTOFF ADJUSTMENT	Variable range	Initial setting value	R	0 ~255	20	G	0 ~255	20	B	0 ~255	20
CUTOFF ADJUSTMENT	Variable range	Initial setting value														
R	0 ~255	20														
G	0 ~255	20														
B	0 ~255	20														

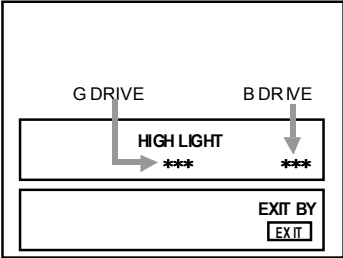
Item	Measuring instrument	Test point	Adjustment item	Description									
WHITE BALANCE (High Light) adjustment	Signal Generator Remote control unit		G DRIVE B DRIVE	<ol style="list-style-type: none"> 1. Receive the NTSC black and white signal (color off). 2. Select the HIGH LIGHT mode in the SERVICE MENU. 3. Confirm the initial setting value of "G DRIVE" and "B DRIVE". 4. Adjust the screen color to white with the ⑤, ⑥, ⑧ and ⑨ keys of the remote control unit. 									
					<p style="text-align: center;">HIGH LIGHT MODE</p> 								
				<table border="1"> <thead> <tr> <th>DRIVE ADJUSTMENT</th> <th>Variable range</th> <th>Initial setting value</th> </tr> </thead> <tbody> <tr> <td>G</td> <td>0 ~ 255</td> <td>128</td> </tr> <tr> <td>B</td> <td>0 ~ 255</td> <td>128</td> </tr> </tbody> </table>	DRIVE ADJUSTMENT	Variable range	Initial setting value	G	0 ~ 255	128	B	0 ~ 255	128
DRIVE ADJUSTMENT	Variable range	Initial setting value											
G	0 ~ 255	128											
B	0 ~ 255	128											
SUB BRIGHT adjustment	Remote control unit		No.2 BRIGHT	<ol style="list-style-type: none"> 1. Receive a NTSC broadcast. 2. Select "No.2 BRIGHT" of the PICTURE mode in SERVICE MENU. 3. Confirm the initial setting value of the "No.2 BRIGHT" . 4. If the brightness is not the best with the initial setting value, make fine adjustment of the "No.2 BRIGHT" until you get the optimum brightness. 									
				<table border="1"> <thead> <tr> <th>BRIGHT ADJUSTMENT</th> <th>Variable range</th> <th>Initial setting value</th> </tr> </thead> <tbody> <tr> <td>No.2 BRIGHT</td> <td>0 ~ 127</td> <td>64</td> </tr> </tbody> </table>	BRIGHT ADJUSTMENT	Variable range	Initial setting value	No.2 BRIGHT	0 ~ 127	64			
BRIGHT ADJUSTMENT	Variable range	Initial setting value											
No.2 BRIGHT	0 ~ 127	64											
SUB CONTRAST adjustment	Remote control unit		No.1 PICTURE	<ol style="list-style-type: none"> 1. Receive a NTSC broadcast. 2. Select "No.1 PICTURE" of the PICTURE mode in SERVICE MENU. 3. Confirm the initial setting value of the "No.1 PICTURE". 4. If the contrast is not the best with the initial setting value, make fine adjustment of the "No.1 PICTURE" until you get the optimum contrast. 									
				<table border="1"> <thead> <tr> <th>PICTURE ADJUSTMENT</th> <th>Variable range</th> <th>Initial setting value</th> </tr> </thead> <tbody> <tr> <td>No.1 PICTURE</td> <td>0 ~ 127</td> <td>60</td> </tr> </tbody> </table>	PICTURE ADJUSTMENT	Variable range	Initial setting value	No.1 PICTURE	0 ~ 127	60			
PICTURE ADJUSTMENT	Variable range	Initial setting value											
No.1 PICTURE	0 ~ 127	60											

Item	Measuring instrument	Test point	Adjustment item	Description												
SUB COLOR adjustment	Remote control unit		<p>No.3 COL. PALM</p> <p>No.4 COL. PALN</p> <p>No.5 COL. NTSC</p>	<p>[PAL-M]</p> <ol style="list-style-type: none"> 1. Receive a PAL-M broadcast. 2. Select "No.3 COL. PALM" of the PICTURE mode in SERVICE MENU. 3. Confirm the initial setting value of the "No.3 COL. PALM". 4. If the color is not the best with the initial setting value, make fine adjustment until you get the best color. <p>[PAL-N]</p> <ol style="list-style-type: none"> 1. Receive a PAL-N broadcast. 2. Select "No.4 COL. PALN" of the PICTURE mode in SERVICE MENU. 3. Confirm the initial setting value of the "No.4 COL. PALN". 4. If the color is not the best with the initial setting value, make fine adjustment until you get the best color. <p>[NTSC]</p> <ol style="list-style-type: none"> 1. Receive a NTSC broadcast. 2. Select "No.5 COL. NTSC" of the PICTURE mode in SERVICE MENU. 3. Confirm the initial setting value of the "No.5 COL. NTSC". 4. If the color is not the best with the initial setting value, make fine adjustment until you get the best color. <table border="1" data-bbox="906 1087 1472 1266"> <thead> <tr> <th>COLOR ADJUSTMENT</th> <th>Variable range</th> <th>Initial setting value</th> </tr> </thead> <tbody> <tr> <td>No.3 COL. PAL-M</td> <td>0 ~ 127</td> <td>80</td> </tr> <tr> <td>No.4 COL. PAL-N</td> <td>0 ~ 127</td> <td>80</td> </tr> <tr> <td>No.5 COL. NTSC</td> <td>0 ~ 127</td> <td>95</td> </tr> </tbody> </table>	COLOR ADJUSTMENT	Variable range	Initial setting value	No.3 COL. PAL-M	0 ~ 127	80	No.4 COL. PAL-N	0 ~ 127	80	No.5 COL. NTSC	0 ~ 127	95
COLOR ADJUSTMENT	Variable range	Initial setting value														
No.3 COL. PAL-M	0 ~ 127	80														
No.4 COL. PAL-N	0 ~ 127	80														
No.5 COL. NTSC	0 ~ 127	95														
SUB TINT adjustment	Remote control unit		No. 6 TINT	<ol style="list-style-type: none"> 1. Receive a NTSC color bar signal. 2. Select "No. 6 TINT" of the PICTURE mode in SERVICE MENU. 3. Confirm the initial setting value of the "No. 6 TINT". 4. If the tint is not the best with the initial setting value, make fine adjustment until you get the best tint. <table border="1" data-bbox="911 1696 1468 1837"> <thead> <tr> <th>TINT ADJUSTMENT</th> <th>Variable range</th> <th>Initial setting value</th> </tr> </thead> <tbody> <tr> <td>No.6 TINT</td> <td>0 ~ 127</td> <td>65</td> </tr> </tbody> </table>	TINT ADJUSTMENT	Variable range	Initial setting value	No.6 TINT	0 ~ 127	65						
TINT ADJUSTMENT	Variable range	Initial setting value														
No.6 TINT	0 ~ 127	65														

MTS CIRCUIT ADJUSTMENT

Item	Measuring instrument	Test point	Adjustment part	Description
MTS INPUT LEVEL check	Remote control unit		No.2 IN LEVEL	<ol style="list-style-type: none"> 1. Select the "No.2 IN LEVEL" of the SOUND mode in SERVICE MENU. 2. Verify that the "No.2 IN LEVEL" is set at its initial setting value.
MTS STEREO VCO adjustment	Signal generator Frequency counter Remote control unit	R OUT [AUDIO OUT]	No.3 FH MON No.4 ST VCO	<ol style="list-style-type: none"> 1. Receive a NTSC RF signal (non modulated sound signal) from the antenna terminal. 2. Select the "No.3 FH MON" of SOUND mode in SERVICE MENU, change the setting value from 0 to 1. 3. Connect the frequency connector to R OUT RCA pin of the AUDIO OUT. 4. Select the "No.4 ST VCO". 5. Confirm the initial setting value of the "No.4 ST VCO". 6. Adjust the "No.4 ST VCO" so that the frequency counter will display 15.73kHz±0.1kHz. 7. Select the "No.3 FH MON" of the SOUND mode, and reset the setting value from 1 to 0.
MTS SAP VCO adjustment	Signal generator Frequency counter Remote control unit	MPX Connector 4 pin SDA 3 pin GND [MAIN PWB] R OUT [AUDIO OUT]	No.9 5FH MON. No.10 SAP VCO.	<ol style="list-style-type: none"> 1. Receive a NTSC RF signal (non modulated sound signal) from the antenna terminal. 2. Connect between pin 4 of MPX connector and GND (pin 3 of MPX connector) through 1MΩ resistor. 3. Select the "No.9 5FH MON." of the SOUND mode in SERVICE MENU, and reset the setting value from 0 to 1. 4. Connect the frequency connector to R OUT RCA pin of the AUDIO OUT. 5. Select the "No.10 SAP VCO". 6. Confirm the initial setting value of "No.10 SAP VCO". 7. Adjust the "No.10 SAP VCO" so that the frequency connector will display 78.67kHz±0.5kHz. 8. Select the "No.9 5FH MON." of the SOUND mode, and reset the setting value from 1 to 0.
MTS FILTER check	Remote control unit		No.6 FILTER	<ol style="list-style-type: none"> 1. Select the "No.6 FLTER" of the SOUND mode in SERVICE MENU. 2. Verify that the "No.6 FLTER" is set at its initial setting value.
MTS SEPARATION adjustment	TV audio Multiplex signal generator Oscilloscope Remote control unit	L OUT R OUT [AUDIO OUT]	No.7 LOW SEP. No.8 HI SEP.	<ol style="list-style-type: none"> 1. Input a stereo L signal (300Hz) from the TV Audio multiplex signal generator to the antenna terminal. (NTSC) 2. Connect an oscilloscope to L OUT RCA pin of the AUDIO OUT, and display one cycle portion of the 300Hz signal. 3. Change the connection of the oscilloscope to R OUT RCA pin of the AUDIO OUT, and enlarge the voltage axis. 4. Select the "No.7 LOW SEP." of the SOUND mode in SERVICE MENU. 5. Confirm the initial setting value of the "No.7 LOW SEP.". 6. Adjust the "No.7 LOW SEP." so that the stroke element of the 300Hz signal will become minimum. 7. Change the signal to 3kHz, and similarly adjust the "No.8 HI SEP.".

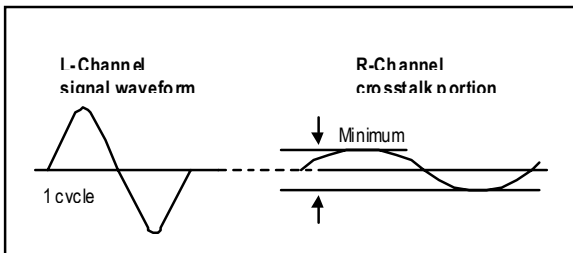

PURITY, CONVERGENCE

PURITY ADJUSTMENT

1. Demagnetize CRT with the demagnetizer.
2. Loosen the retainer screw of the deflection yoke.
3. Remove the wedges.
4. Input a green raster signal from the signal generator, and turn the screen to green raster.
5. Move the deflection yoke backward.
6. Bring the long lug of the purity magnets on the short lug and position them horizontally. (Fig.2)
7. Adjust the gap between two lugs so that the GREEN RASTER will come into the center of the screen. (Fig.3)
8. Move the deflection yoke forward, and fix the position of the deflection yoke so that the whole screen will become green.
9. Insert the wedge to the top side of the deflection yoke so that it will not move.
10. Input a cross hatch signal.
11. Verify that the screen is horizontal.
12. Input red and blue raster signals, and make sure that purity is properly adjusted.

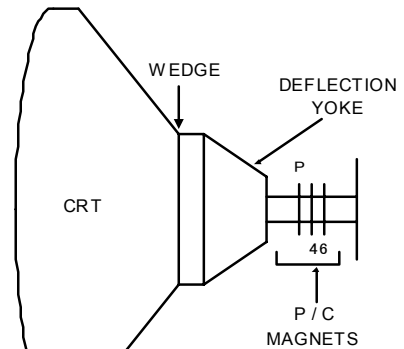

• P/C MAGNETS

- P : PURITY MAGNET
- 4 : 4 POLES (convergence magnets)
- 6 : 6 POLES (convergence magnets)

Fig. 1

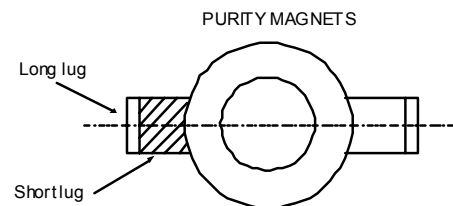

Bring the long lug over the short lug and position them horizontally.

Fig. 2

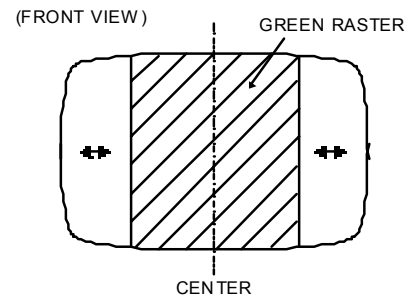

Fig. 3

STATIC CONVERGENCE ADJUSTMENT

1. Input a cross hatch signal.
2. Using 4-pole convergence magnets, overlap the red and blue lines in the center of the screen (Fig.1) and turn them to magenta (red/blue).
3. Using 6-pole convergence magnets, overlap the magenta (red/blue) and green lines in the center of the screen and turn them to white.
4. Repeat 2 and 3 above, and make best convergence.

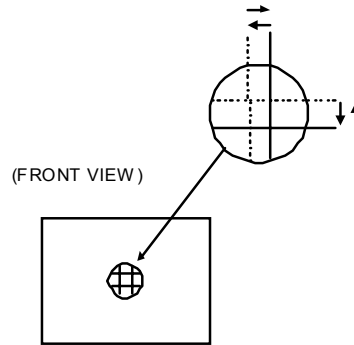

Fig.1

DYNAMIC CONVERGENCE ADJUSTMENT

1. Move the deflection yoke up and down and overlap the lines in the periphery. (Fig. 2)
2. Move the deflection yoke left to right and overlap the lines in the periphery. (Fig. 3)
3. Repeat 1 and 2 above, and make best convergence.

- After adjustment, fix the wedge at the original position.
Fasten the retainer screw of the deflection yoke.
Fix the 6 magnets with glue.

[Adjustment for the models equipped with differential coil.]

If the lines are not aligned, as shown in Fig. 4, correct them with the differential coil attached to the deflection yoke.

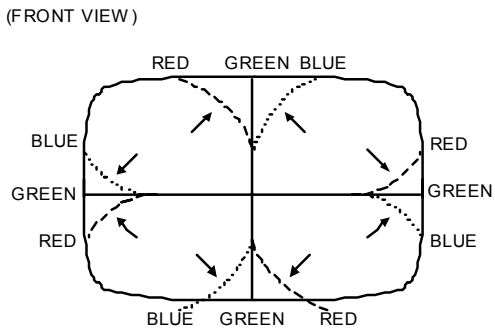

Fig.2

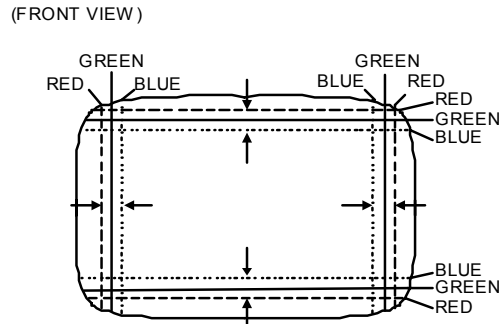

Fig.3

(FRONT VIEW)

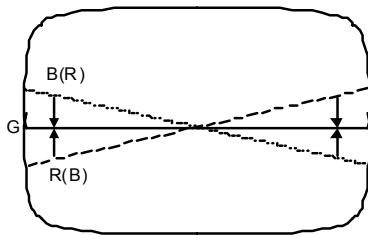

Fig.4

HOW TO CHECK THE HIGH VOLTAGE HOLD DOWN CIRCUIT

1. HIGH VOLTAGE HOLD DOWN CIRCUIT

After repairing the high voltage hold down circuit as shown in Fig. 1.
This circuit shall be checked to operate correctly.

2. CHECKING OF THE HIGH VOLTAGE HOLD DOWN CIRCUIT

- (1) Turn the power switch on.
- (2) As shown in Fig.2, set the resistor (between connector 1 & 3).
- (3) Make sure that the screen picture disappears.
- (4) Temporarily unplug the power plug.
- (5) Remove the resistor (between connector 1 & 3).
- (6) Again plug the power plug, make sure that the normal picture is displayed on the screen.

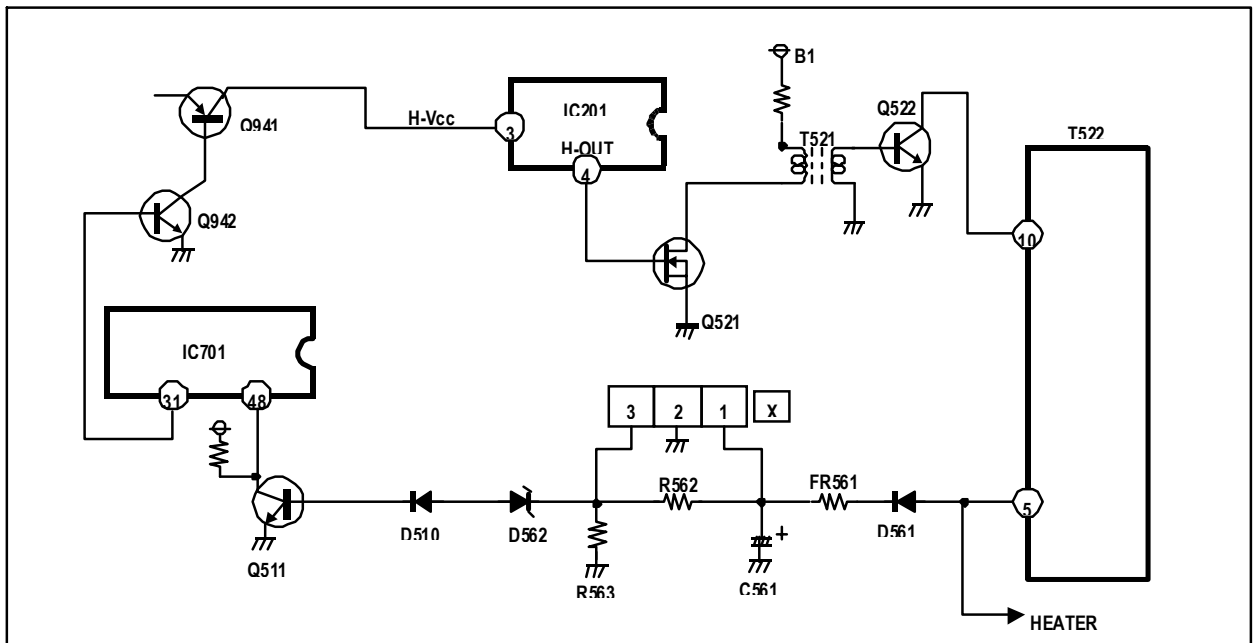

Fig. 1

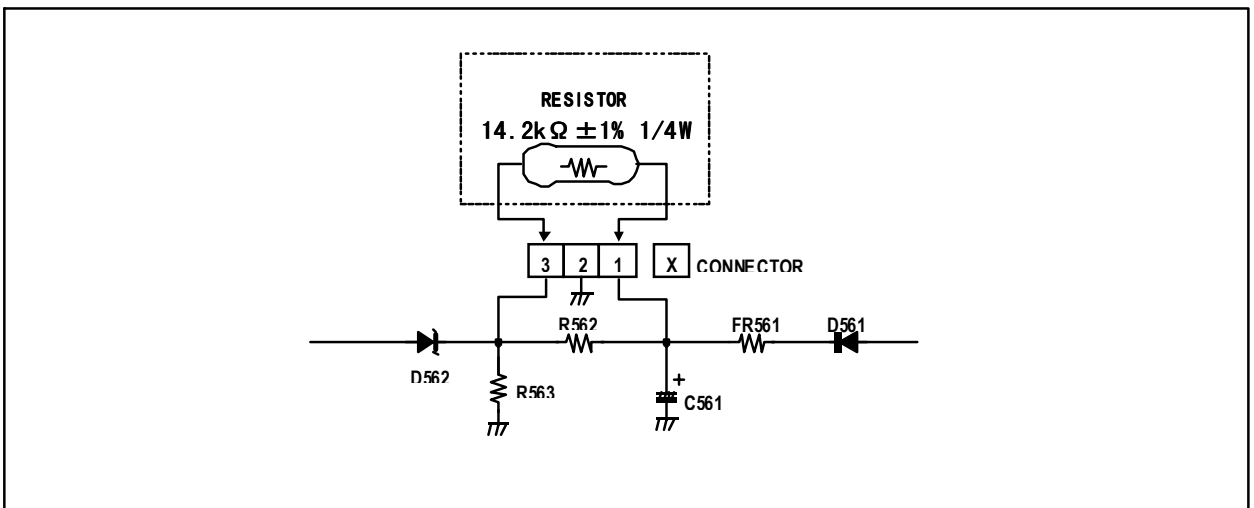

Fig. 2

SELF CHECK FUNCTIONS

1. Outline

This model has self check functions given below. When a malfunction has been detected, the SUB-POWER is turned off and the LED flashes to inform of the failure. The malfunction is detected by the signal input state of the control line connected to the microcomputer.

2. Self check items

Check item	Detected contents	Detection method	Ab normality state
Over-current protector	Operation of over-current protection circuit	The microcomputer detects at 1 second intervals. If NG is detected for more than 1 ms, a malfunction is interpreted.	During an abnormality the sub-power is cutoff. The remote controller power key operation is not recognized and sub-power off is maintained until the power cord is unplugged and reinserted.
X-ray protector	Operation of X-ray protection circuit	The microcomputer detects at 1 second intervals. If NG is detected for more than 1 ms, a malfunction is interpreted	During an abnormality the sub-power is cutoff. The remote controller power key operation is not recognized and sub-power off is maintained until the power cord is unplugged and reinserted.
CRT NECK protector	When the vertical circuit S-correction capacitor C413 is shorted, detect the potential drop of the C413, and prevent the bum damage to the CRT NECK.	The microcomputer detects at 1 second intervals. If NG is detected for more than 1 ms, a malfunction is interpreted	During an abnormality the sub-power is cutoff. The remote controller power key operation is not recognized and sub-power off is maintained until the power cord is unplugged and reinserted.

3. Self check indicating function

The self check function begins detection about 5 seconds after power is supplied.

In the event a malfunction is detected, the sub-power is cutoff immediately.

At this time, the POWER/ON TIMER LED flashes to inform of the malfunction.

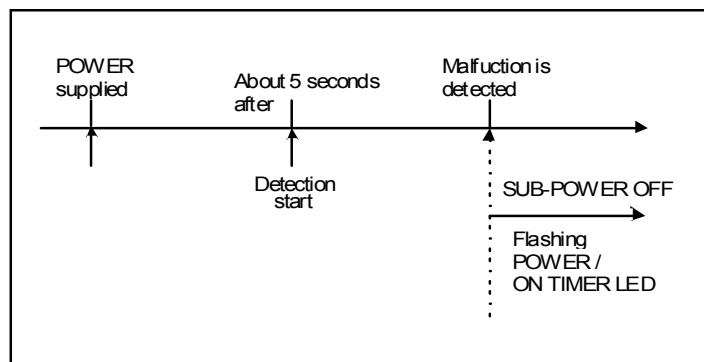

Item	LED flashing intervals	Priority of detection
OCP/X-ray	At 0.5-second intervals	1
NECK	At 0.5-second intervals	2

- Because OCP and X-ray protectors are inputted to the same pin in the microcomputer, the judgement will be logical sum (OR).

PARTS LIST

CAUTION

- The parts identified by the \triangle symbol are important for the safety. Whenever replacing these parts, be sure to use specified ones to secure the safety.
- The parts not indicated in this Parts List and those which are filled with lines — in the Parts No. columns will not be supplied.
- P. W. Board Ass'y will not be supplied, but those which are filled with the Parts No. in the Parts No. columns will be supplied.

ABBREVIATIONS OF RESISTORS, CAPACITORS AND TOLERANCES

RESISTORS		CAPACITORS	
C R	Carbon Resistor	C CAP.	Ceramic Capacitor
F R	Fusible Resistor	E CAP.	Electrolytic Capacitor
P R	Plate Resistor	M CAP.	Mylar Capacitor
V R	Variable Resistor	HV CAP.	High Voltage Capacitor
HV R	High Voltage Resistor	MF CAP.	Metalized Film Capacitor
MF R	Metal Film Resistor	MM CAP.	Metalized Mylar Capacitor
MG R	Metal Glazed Resistor	MP CAP.	Metalized Polystyrol Capacitor
MP R	Metal Plate Resistor	PP CAP.	Polypropylene Capacitor
OM R	Metal Oxide Film Resistor	PS CAP.	Polystyrol Capacitor
CMF R	Coating Metal Film Resistor	TF CAP.	Thin Film Capacitor
UNF R	Non-Flammable Resistor	MPP CAP.	Metalized Polypropylene Capacitor
CH V R	Chip Variable Resistor	TAN. CAP.	Tantalum Capacitor
CH MG R	Chip Metal Glazed Resistor	CH C CAP.	Chip Ceramic Capacitor
COMP. R	Composition Resistor	BP E CAP.	Bi-Polar Electrolytic Capacitor
LPTC R	Linear Positive Temperature Coefficient Resistor	CH AL E CAP.	Chip Aluminum Electrolytic Capacitor
		CH AL BP CAP.	Chip Aluminum Bi-Polar Capacitor
		CH TAN. E CAP.	Chip Tantalum Electrolytic Capacitor
		CH AL BP E CAP.	Chip Tantalum Bi-Polar Electrolytic Capacitor

TOLERANCES									
F	G	J	K	M	N	R	H	Z	P
±1%	±2%	±5%	±10%	±20%	±30%	+30% -10%	+50% -10%	+80% -20%	+100% -0%

CONTENTS

- USING PW BOARD & REMOTE CONTROL UNIT 32
- EXPLODED VIEW PARTS LIST 32
- EXPLODED VIEW 33
- PRINTED WIRING BOARD PARTS LIST
 - MAIN PW BOARD ASS'Y (With CRT SOCKET PW BOARD) 34
 - FRONT CONTROL PW BOARD ASS'Y 38
- REMOTE CONTROL UNIT PARTS LIST 39
- PACKING 39
- PACKING PARTS LIST 39

USING P.W. BOARD & REMOTE CONTROL UNIT

Model	AV-T2922/AR
P.W.B ASS'Y	
MAIN P.W.B (Within CRT SOCKET PWB)	SGA-1020A-R2
FRONT CONTROL PWB	SGA-4005A-R2
REMOTE CONTROL UNIT	RM-C363-1H

EXPLODED VIEW PARTS LIST

△ Ref.No.	Part No.	Part Name	Description
△ V01	A68AJB82X02	PICTURE TUBE(C)	Inc.DY,PC MAGNET, WEDGE
△ L01	CEL0058-001J3	DEG.COIL	
△ T1522	QQH0115-001	H.V.TRANSF.	(Within MAIN PWB)
△ 1	LC10571-002A-D	FRONT CABINET	
2	CHGB0015-0B	BRAIDED WIRE	
3	CHGB0016-0C	BRAIDED WIRE(SUB)	
6	CEB5S12D-04KJ2	SPEAKER	(×2)SP01,SP02
△ 7	LC20217-004B-A	CONTROL KNOB	
△ 8	LC30856-002A-A	POWER KNOB	
△ 9	CM12985-003-VA	CHASSIS BASE	
△ 10	QMPR150-200-JC	POWER CORD	
△ 11	CM23169-001-A	POWER CORD CLAMP	
△ 12	LC10572-001B-D	REAR COVER	
13	QYSB5FG4016Z	TAPPING SCREW	(×11)
14	QYSB5B3010Z	TAPPING SCREW	(×2)
△ 15	LC30462-008A-D	RATING LABEL	
△ 16	LC30191-002A-A	REMOCON LENS	
17	CM48006-007-C	JVC MARK	

EXPLODED VIEW

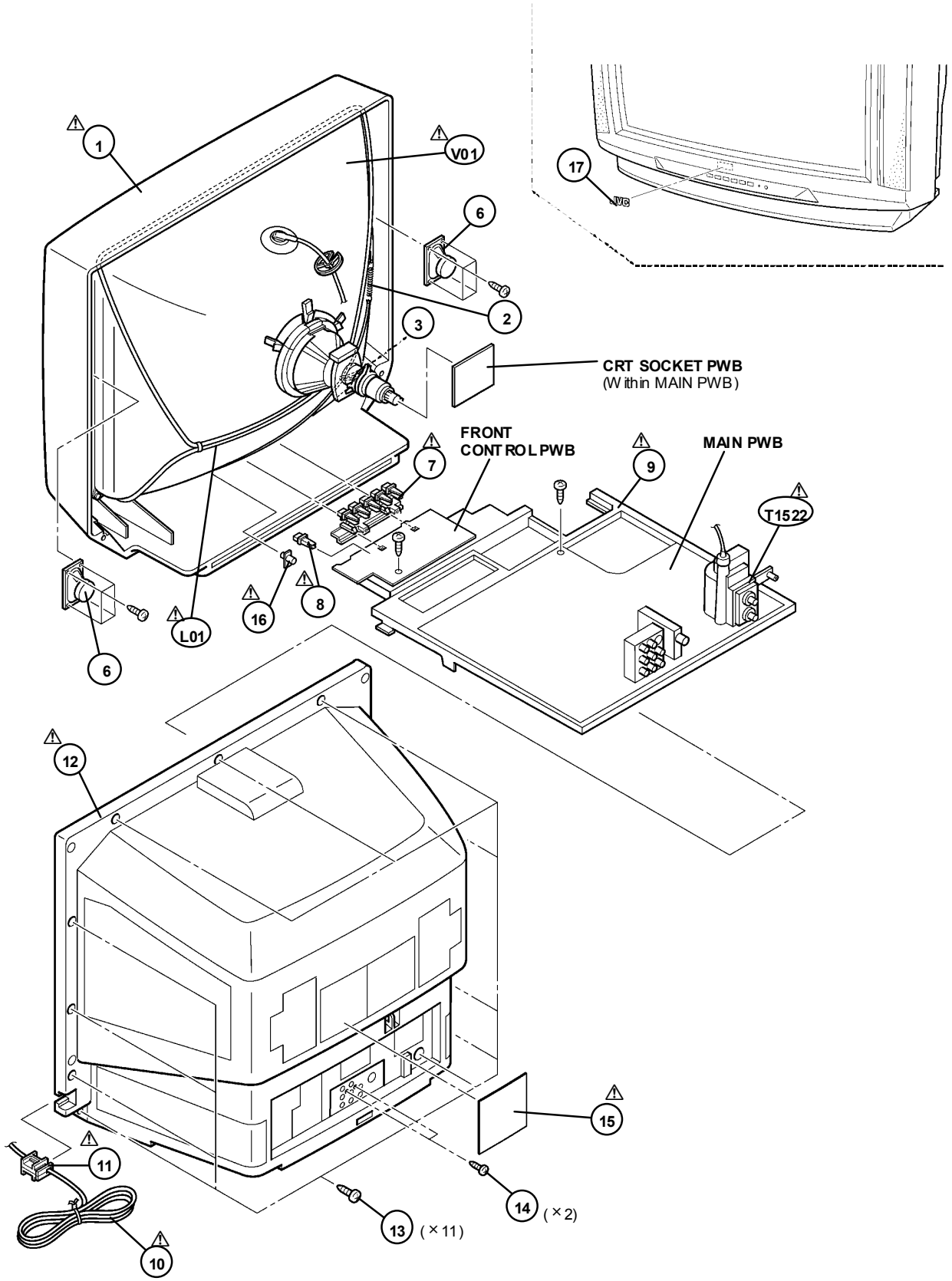

PRINTED WIRING BOARD PARTS LIST

MAIN PW BOARD ASS'Y (SGA-1020A-R2)

Symbol No.	Part No.	Part Name	Description
RESISTOR			
R1001	NRSA02J-563X	MG R	56kΩ 1/10W J
R1003-04	NRSA02J-561X	MG R	560Ω 1/10W J
R1006	NRSA02J-820X	MG R	82Ω 1/10W J
R1101	NRSA02J-562X	MG R	5.6kΩ 1/10W J
R1102	NRSA02J-182X	MG R	1.8kΩ 1/10W J
R1103	QRE121J-101Y	C R	100Ω 1/2W J
R1104	NRSA02J-180X	MG R	18Ω 1/10W J
R1105	NRSA02J-270X	MG R	27Ω 1/10W J
R1111	NRSA02J-394X	MG R	390kΩ 1/10W J
R1112	NRSA02J-334X	MG R	330kΩ 1/10W J
R1113	NRSA02J-101X	MG R	100Ω 1/10W J
R1116	NRSA02J-680X	MG R	68Ω 1/10W J
R1131	NRSA02J-102X	MG R	1kΩ 1/10W J
R1132	NRSA02J-331X	MG R	330Ω 1/10W J
R1133	NRSA02J-102X	MG R	1kΩ 1/10W J
R1134	NRSA02J-271X	MG R	270Ω 1/10W J
R1135	NRSA02J-471X	MG R	470Ω 1/10W J
R1161	NRSA02J-332X	MG R	3.3kΩ 1/10W J
R1162	NRSA02J-0R0X	MG R	0.0Ω 1/10W J
R1163	NRSA02J-103X	MG R	10kΩ 1/10W J
R1164	NRSA02J-102X	MG R	1kΩ 1/10W J
R1165	NRSA02J-273X	MG R	27kΩ 1/10W J
R1166	NRSA02J-103X	MG R	10kΩ 1/10W J
R1167	NRSA02J-102X	MG R	1kΩ 1/10W J
R1168	NRSA02J-101X	MG R	100Ω 1/10W J
R1169	NRSA02J-561X	MG R	560Ω 1/10W J
R1170	NRSA02J-683X	MG R	68kΩ 1/10W J
R1201	NRSA02J-821X	MG R	820Ω 1/10W J
R1202	NRSA02J-102X	MG R	1kΩ 1/10W J
R1203	NRSA02J-821X	MG R	820Ω 1/10W J
R1204	NRSA02J-681X	MG R	680Ω 1/10W J
R1205	NRSA02J-152X	MG R	1.5kΩ 1/10W J
R1213	NRSA02J-391X	MG R	390Ω 1/10W J
R1215	NRSA02J-824X	MG R	820kΩ 1/10W J
R1216	NRSA02J-0R0X	MG R	0.0Ω 1/10W J
R1217	NRSA02J-563X	MG R	56kΩ 1/10W J
R1220	NRSA02J-471X	MG R	470Ω 1/10W J
R1251-52	NRSA02J-750X	MG R	75Ω 1/10W J
R1301	NRSA02J-102X	MG R	1kΩ 1/10W J
R1303-04	NRSA02J-562X	MG R	5.6kΩ 1/10W J
R1307	NRSA02J-472X	MG R	4.7kΩ 1/10W J
R1308	NRSA02J-682X	MG R	6.8kΩ 1/10W J
R1309	NRSA02J-103X	MG R	10kΩ 1/10W J
R1311	NRSA02J-273X	MG R	27kΩ 1/10W J
R1312	NRSA02J-0R0X	MG R	0.0Ω 1/10W J
R1314	NRSA02J-0R0X	MG R	0.0Ω 1/10W J
R1341	NRSA02J-121X	MG R	120Ω 1/10W J
R1342-43	NRSA02J-333X	MG R	33kΩ 1/10W J
R1351-53	NRSA02J-151X	MG R	150Ω 1/10W J
R1354-56	NRSA02J-331X	MG R	330Ω 1/10W J
R1357-59	NRSA02J-101X	MG R	100Ω 1/10W J
R1360-62	QRZ0111-152	C R	1.5kΩ 1/2W K
R1363-65	QRG029J-123	OM R	12kΩ 2W J
R1366-68	NRSA02J-272X	MG R	2.7kΩ 1/10W J
R1401	NRSA02J-103X	MG R	10kΩ 1/10W J
R1402	NRSA02J-682X	MG R	6.8kΩ 1/10W J
R1403	NRSA02J-0R0X	MG R	0.0Ω 1/10W J
R1404	NRSA02J-102X	MG R	1kΩ 1/10W J
R1405	NRSA02J-221X	MG R	220Ω 1/10W J
R1406-08	NRSA02J-472X	MG R	4.7kΩ 1/10W J
R1410	NRSA02J-0R0X	MG R	0.0Ω 1/10W J
R1412	QRE121J-3R9Y	C R	3.9Ω 1/2W J
R1413	QRE121J-561Y	C R	560Ω 1/2W J
R1414	QRX016J-R68	MF R	0.68Ω 1W J
R1415	QRE121J-102Y	C R	1kΩ 1/2W J
R1416	NRSA02J-563X	MG R	56kΩ 1/10W J
R1418	NRSA02J-563X	MG R	56kΩ 1/10W J
R1419	NRSA02J-183X	MG R	18kΩ 1/10W J

Symbol No.	Part No.	Part Name	Description
RESISTOR			
R1421	NRSA02J-0R0X	MG R	0.0Ω 1/10W J
R1422	NRSA02J-0R0X	MG R	0.0Ω 1/10W J
R1423	NRSA02J-103X	MG R	10kΩ 1/10W J
R1501	NRSA02J-0R0X	MG R	0.0Ω 1/10W J
R1503	NRSA02J-103X	MG R	10kΩ 1/10W J
R1504	NRSA02J-104X	MG R	100kΩ 1/10W J
R1505	NRSA02J-822X	MG R	8.2kΩ 1/10W J
R1506	NRSA02J-102X	MG R	1kΩ 1/10W J
R1510	NRSA02J-0R0X	MG R	0.0Ω 1/10W J
R1512	NRSA02J-103X	MG R	10kΩ 1/10W J
R1513	NRSA02J-0R0X	MG R	0.0Ω 1/10W J
R1514	NRSA02J-333X	MG R	33kΩ 1/10W J
R1521	QRL039J-182	OM R	1.8kΩ 3W J
R1523	NRSA02J-222X	MG R	2.2kΩ 1/10W J
R1524	QRE121J-103Y	C R	10kΩ 1/2W J
R1525	QRG016J-561	OM R	560Ω 1W J
R1526	QRL029J-152	OM R	1.5kΩ 2W J
R1529	NRSA02J-621X	MG R	620Ω 1/10W J
R1532	QRL039J-182	OM R	1.8kΩ 3W J
R1533	QRE121J-220Y	C R	22Ω 1/2W J
R1544	QRL029J-223	OM R	22kΩ 2W J
R1562	QRA14CF-6341Y	MF R	6.34kΩ 1/4W F
R1563	QRA14CF-3241Y	MF R	3.24kΩ 1/4W F
R1581	QRE121J-273Y	C R	27kΩ 1/2W J
R1582	QRE121J-393Y	C R	39kΩ 1/2W J
R1584	QRE121J-223Y	C R	22kΩ 1/2W J
R1603	NRSA02J-682X	MG R	6.8kΩ 1/10W J
R1605	NRSA02J-821X	MG R	820Ω 1/10W J
R1607	NRSA02J-682X	MG R	6.8kΩ 1/10W J
R1609	NRSA02J-821X	MG R	820Ω 1/10W J
R1611	NRSA02J-223X	MG R	22kΩ 1/10W J
R1613	NRSA02J-333X	MG R	33kΩ 1/10W J
R1620	NRSA02J-183X	MG R	18kΩ 1/10W J
R1621	QRT039J-2R2	MF R	2.2Ω 3W J
R1622	NRSA02J-183X	MG R	18kΩ 1/10W J
R1626	NRSA02J-822X	MG R	8.2kΩ 1/10W J
R1631	NRSA02J-473X	MG R	47kΩ 1/10W J
R1651	NRSA02J-102X	MG R	1kΩ 1/10W J
R1652	NRSA02J-561X	MG R	560Ω 1/10W J
R1653	NRSA02J-272X	MG R	2.7kΩ 1/10W J
R1654	NRSA02J-333X	MG R	33kΩ 1/10W J
R1655	NRSA02J-332X	MG R	3.3kΩ 1/10W J
R1656	NRV02D-152X	MF R	1.5kΩ 1/10W D
R1658	NRV02D-153X	MF R	15kΩ 1/10W D
R1660	NRSA02J-512X	MG R	5.1kΩ 1/10W J
R1661	NRSA02J-473X	MG R	47kΩ 1/10W J
R1662-65	NRSA02J-123X	MG R	12kΩ 1/10W J
R1666-67	NRSA02J-562X	MG R	5.6kΩ 1/10W J
R1668	NRSA02J-473X	MG R	47kΩ 1/10W J
R1669-70	NRSA02J-471X	MG R	47kΩ 1/10W J
R1671	NRSA02J-102X	MG R	1kΩ 1/10W J
R1672	NRSA02J-102X	MG R	1kΩ 1/10W J
R1673-74	NRSA02J-823X	MG R	82kΩ 1/10W J
R1675-76	NRSA02J-181X	MG R	180Ω 1/10W J
R1677	NRSA02J-682X	MG R	6.8kΩ 1/10W J
R1678	NRSA02J-223X	MG R	22kΩ 1/10W J
R1679	NRSA02J-223X	MG R	22kΩ 1/10W J
R1680	NRSA02J-223X	MG R	22kΩ 1/10W J
R1681	NRSA02J-223X	MG R	22kΩ 1/10W J
R1682	NRSA02J-683X	MG R	68kΩ 1/10W J
R1685	NRSA02J-0R0X	MG R	0.0Ω 1/10W J
R1686	NRSA02J-0R0X	MG R	0.0Ω 1/10W J
R1687	NRSA02J-0R0X	MG R	0.0Ω 1/10W J
R1688	NRSA02J-0R0X	MG R	0.0Ω 1/10W J
R1691	NRSA02J-102X	MG R	1kΩ 1/10W J
R1692	NRSA02J-102X	MG R	1kΩ 1/10W J
R1701	NRSA02J-563X	MG R	56kΩ 1/10W J
R1702	NRSA02J-223X	MG R	22kΩ 1/10W J

△ Symbol No. Part No. Part Name Description

RESISTOR

R1708	NRSA02J-0R0X	MG R	0.0Ω 1/10W J
R1704	NRSA02J-103X	MG R	10kΩ 1/10W J
R1705	NRSA02J-102X	MG R	1kΩ 1/10W J
R1706	NRSA02J-563X	MG R	56kΩ 1/10W J
R1707	NRSA02J-103X	MG R	10kΩ 1/10W J
R1708	NRSA02J-0R0X	MG R	0.0Ω 1/10W J
R1709	NRSA02J-103X	MG R	10kΩ 1/10W J
R1710	NRSA02J-102X	MG R	1kΩ 1/10W J
R1711	NRSA02J-124X	MG R	120kΩ 1/10W J
R1712	NRSA02J-184X	MG R	180kΩ 1/10W J
R1713	NRSA02J-102X	MG R	1kΩ 1/10W J
R1714	NRSA02J-103X	MG R	10kΩ 1/10W J
R1715	NRSA02J-224X	MG R	220kΩ 1/10W J
R1716	NRSA02J-102X	MG R	1kΩ 1/10W J
R1717	NRSA02J-102X	MG R	1kΩ 1/10W J
R1721	NRSA02J-102X	MG R	1kΩ 1/10W J
R1722	NRSA02J-561X	MG R	560Ω 1/10W J
R1724	NRSA02J-221X	MG R	220Ω 1/10W J
R1725	NRSA02J-682X	MG R	6.8kΩ 1/10W J
R1726	NRSA02J-221X	MG R	220Ω 1/10W J
R1727	NRSA02J-682X	MG R	6.8kΩ 1/10W J
R1728	NRSA02J-221X	MG R	220Ω 1/10W J
R1729	NRSA02J-682X	MG R	6.8kΩ 1/10W J
R1730	NRSA02J-221X	MG R	220Ω 1/10W J
R1731	NRSA02J-682X	MG R	6.8kΩ 1/10W J
R1732	NRSA02J-682X	MG R	6.8kΩ 1/10W J
R1734	NRSA02J-102X	MG R	1kΩ 1/10W J
R1735-36	NRSA02J-473X	MG R	47kΩ 1/10W J
R1737	NRSA02J-683X	MG R	68kΩ 1/10W J
R1738	NRSA02J-562X	MG R	5.6kΩ 1/10W J
R1740	NRSA02J-101X	MG R	100Ω 1/10W J
R1741	NRSA02J-103X	MG R	10kΩ 1/10W J
R1742	NRSA02J-102X	MG R	1kΩ 1/10W J
R1743	NRSA02J-392X	MG R	3.9kΩ 1/10W J
R1744	NRSA02J-102X	MG R	1kΩ 1/10W J
R1745	NRSA02J-392X	MG R	3.9kΩ 1/10W J
R1746	NRSA02J-102X	MG R	1kΩ 1/10W J
R1747	NRSA02J-392X	MG R	3.9kΩ 1/10W J
R1748	NRSA02J-102X	MG R	1kΩ 1/10W J
R1749	NRSA02J-102X	MG R	1kΩ 1/10W J
R1754-55	NRSA02J-222X	MG R	2.2kΩ 1/10W J
R1756	NRSA02J-103X	MG R	10kΩ 1/10W J
R1761	NRSA02J-102X	MG R	1kΩ 1/10W J
R1762	NRSA02J-153X	MG R	15kΩ 1/10W J
R1764	NRSA02J-105X	MG R	1MΩ 1/10W J
R1765	NRSA02J-122X	MG R	1.2kΩ 1/10W J
R1766	NRSA02J-102X	MG R	1kΩ 1/10W J
R1771-72	NRSA02J-221X	MG R	220Ω 1/10W J
R1773	NRSA02J-0R0X	MG R	0.0Ω 1/10W J
R1774	NRSA02J-102X	MG R	1kΩ 1/10W J
R1775	NRSA02J-102X	MG R	1kΩ 1/10W J
R1799	NRSA02J-333X	MG R	33kΩ 1/10W J
R1801-03	NRSA02J-221X	MG R	220Ω 1/10W J
R1811	NRSA02J-0R0X	MG R	0.0Ω 1/10W J
R1812	NRSA02J-0R0X	MG R	0.0Ω 1/10W J
R1813	NRSA02J-0R0X	MG R	0.0Ω 1/10W J
R1815	NRSA02J-0R0X	MG R	0.0Ω 1/10W J
△ R1901	QRF154K-4R7	UNF R	4.7Ω 15W K
△ R1902	QRL09J-393	OM R	39kΩ 3W J
△ R1905	QRF154J-680	UNF R	68Ω 15W J
R1910	QRE121J-564Y	C R	560kΩ 1/2W J
R1911	QRN141J-183Y	C R	18kΩ 1/4W J
R1921	QRE121J-681Y	C R	680Ω 1/2W J
R1922-23	QRT029J-R22	M R	0.22Ω 2W J
R1924	QRE121J-103Y	C R	10kΩ 1/2W J
R1925	QRE121J-102Y	C R	1kΩ 1/2W J
R1926	QRE121J-152Y	C R	1.5kΩ 1/2W J
R1929	QRE121J-332Y	C R	3.3kΩ 1/2W J
R1932	QRE121J-4R7Y	C R	4.7Ω 1/2W J
R1941	QRK129J-150	C R	15Ω 1/2W J

△ Symbol No. Part No. Part Name Description

RESISTOR

R1942	NRSA02J-223X	MG R	22kΩ 1/10W J
R1943	QRE121J-152Y	C R	1.5kΩ 1/2W J
R1944	NRSA02J-103X	MG R	10kΩ 1/10W J
R1945	NRSA02J-332X	MG R	3.3kΩ 1/10W J
R1946	NRSA02J-123X	MG R	12kΩ 1/10W J
R1948	NRSA02J-152X	MG R	1.5kΩ 1/10W J
R1949	NRSA02J-153X	MG R	15kΩ 1/10W J
R1950	NRSA02J-103X	MG R	10kΩ 1/10W J
R1951	NRSA02J-332X	MG R	3.3kΩ 1/10W J
R1952	NRSA02J-472X	MG R	4.7kΩ 1/10W J
R1959	NRSA02J-0R0X	MG R	0.0Ω 1/10W J
R1961	QRT029J-1R2	MF R	1.2Ω 2W J
R1962	QRT029J-1R2	MF R	1.2Ω 2W J
R1964	QRE121J-272Y	C R	2.7kΩ 1/2W J
R1965	QRE121J-473Y	C R	47kΩ 1/2W J
R1966	QRE121J-223Y	C R	22kΩ 1/2W J
△ R1981	QRZ0057-825	C R	8.2MΩ 1W J

CAPACITOR

C1001	QETN1HM-106Z	E CAP.	10μF 50V M
C1007	QETN1CM-477Z	E CAP.	470μF 16V M
C1008-09	QETN1EM-476Z	E CAP.	47μF 25V M
C1011	NCB21HK-103X	C CAP.	0.01μF 50V K
C1101-02	NCB21HK-103X	C CAP.	0.01μF 50V K
C1104-05	NCB21HK-103X	C CAP.	0.01μF 50V K
C1111	QETN1EM-476Z	E CAP.	47μF 25V M
C1112-14	NCB21HK-103X	C CAP.	0.01μF 50V K
C1116	QFV71HJ-224Z	MF CAP.	0.22μF 50V J
C1117	QETN1EM-476Z	E CAP.	47μF 25V M
C1118	NCB21HK-103X	C CAP.	0.01μF 50V K
C1119	NDC21HJ-681X	C CAP.	680pF 50V J
C1120	QETN1HM-474Z	E CAP.	0.47μF 50V M
C1123-24	NCB21HK-103X	C CAP.	0.01μF 50V K
C1161	QETN1HM-106Z	E CAP.	10μF 50V M
C1163-64	NDC21HJ-470X	C CAP.	47pF 50V J
C1165-66	NCB21HK-103X	C CAP.	0.01μF 50V K
C1202	QETN1CM-107Z	E CAP.	100μF 16V M
C1205	NDC21HJ-680X	C CAP.	68pF 50V J
C1207	QFLC1HJ-104Z	M CAP.	0.1μF 50V J
C1208	QETN1HM-475Z	E CAP.	4.7μF 50V M
C1209	QETN1CM-227Z	E CAP.	220μF 16V M
C1210	NCB21HK-103X	C CAP.	0.01μF 50V K
C1211	NDC21HJ-681X	C CAP.	680pF 50V J
C1212	QFLC1HJ-104Z	M CAP.	0.1μF 50V J
C1213	QETN1HM-105Z	E CAP.	1μF 50V M
C1214	QFLC1HJ-104Z	M CAP.	0.1μF 50V J
C1215	QETN1HM-106Z	E CAP.	10μF 50V M
C1251-52	QETN1HM-106Z	E CAP.	10μF 50V M
C1255	QETN1HM-106Z	E CAP.	10μF 50V M
C1256	QETN1CM-107Z	E CAP.	100μF 16V M
C1291-92	QETN1CM-107Z	E CAP.	100μF 16V M
C1294	QETN1CM-107Z	E CAP.	100μF 16V M
C1296	QETN1CM-107Z	E CAP.	100μF 16V M
C1301-02	NDC21HJ-150X	C CAP.	15pF 50V J
C1303	NDC21HJ-120X	C CAP.	12pF 50V J
C1304	NCB21HK-103X	C CAP.	0.01μF 50V K
C1305	NDC21HJ-120X	C CAP.	12pF 50V J
C1306	QETN1EM-476Z	E CAP.	47μF 25V M
C1307	NCB21HK-103X	C CAP.	0.01μF 50V K
C1308-09	QFLC1HJ-104Z	M CAP.	0.1μF 50V J
C1311	QFV71HJ-334Z	MF CAP.	0.33μF 50V J
C1312	QFLC1HJ-103Z	M CAP.	0.01μF 50V J
C1313	QETN1HM-475Z	E CAP.	4.7μF 50V M
C1342	QETN1HM-335Z	E CAP.	3.3μF 50V M
C1354-55	NDC21HJ-271X	C CAP.	270pF 50V J
C1356	NDC21HJ-331X	C CAP.	330pF 50V J
C1357	QETN1CM-107Z	E CAP.	100μF 16V M
△ C1382	QCZ0121-102	C CAP.	1000pF 3kV Z
C1401-02	QETN1HM-105Z	E CAP.	1μF 50V M

△ Symbol No.	Part No.	Part Name	Description
CAPACITOR			
C1403	QEMGLEK-225Z	E CAP.	2.2 μ F 25V K
C1405	QFLCLHJ-104Z	M CAP.	0.1 μ F 50V J
C1406	QFLCLHJ-103Z	M CAP.	0.01 μ F 50V J
C1410	QETNLVM-107Z	E CAP.	100 μ F 35V M
C1411	QETNLVM-477Z	E CAP.	470 μ F 35V M
C1412	QFLCZAK-393Z	M CAP.	0.039 μ F 100V K
C1413	QETNLVM-228	E CAP.	2200 μ F 35V M
C1414	QETNLHM-105Z	E CAP.	1 μ F 50V M
C1415	QFN31HJ-152Z	M CAP.	1500pF 50V J
C1501	QETNLCH-107Z	E CAP.	100 μ F 16V M
C1503	NCB21HK-103X	C CAP.	0.01 μ F 50V K
C1505-06	NCB21HK-103X	C CAP.	0.01 μ F 50V K
C1507	QETNLHM-105Z	E CAP.	1 μ F 50V M
C1511	QETNLHM-106Z	E CAP.	10 μ F 50V M
C1521	QCB32HK-151Z	C CAP.	150pF 500V K
C1522	QCB32HK-331Z	C CAP.	330pF 500V K
C1523	QETNLCH-105Z	E CAP.	1 μ F 160V M
△ C1524	QFZ0198-133	MPP CAP.	0.013 μ F 1.5KVH \pm 3%
△ C1525	QFZ0119-474	MPP CAP.	0.47 μ F 200V \pm 3%
△ C1526	QEZO03-107	E CAP.	100 μ F 160V M
C1541	QETNDEM-336	E CAP.	33 μ F 250V M
C1542	QCB32HK-821Z	C CAP.	820pF 500V K
C1543	QETNLVM-108	E CAP.	1000 μ F 35V M
C1544	QCB32HK-821Z	C CAP.	820pF 500V K
C1546	QETNLCH-227Z	E CAP.	220 μ F 16V M
C1547	QETNLCH-108Z	E CAP.	1000 μ F 16V M
C1548	QCZ0122-821	C CAP.	
C1561	QETNLVM-107Z	E CAP.	100 μ F 35V M
C1581	QFLCLHJ-473Z	M CAP.	0.047 μ F 50V J
C1583	QFLCLHJ-104Z	M CAP.	0.1 μ F 50V J
C1584	QFLCZAJ-104Z	M CAP.	0.1 μ F 100V J
C1604	QENCLHM-474Z	BP E CAP.	0.47 μ F 50V M
C1607	QENCLHM-474Z	BP E CAP.	0.47 μ F 50V M
C1609	QETNLCH-107Z	E CAP.	100 μ F 16V M
C1613	QETNLEM-108	E CAP.	1000 μ F 25V M
C1615	QETNLEM-108	E CAP.	1000 μ F 25V M
C1617	QETNLEM-108	E CAP.	1000 μ F 25V M
C1618	QFV1HJ-224Z	MF CAP.	0.22 μ F 50V J
C1622	QETNLHM-105Z	E CAP.	1 μ F 50V M
C1623-24	QENCLHM-474Z	BP E CAP.	0.47 μ F 50V M
C1631	QETNLEM-476Z	E CAP.	47 μ F 25V M
C1637-38	NCB21HK-392X	C CAP.	3900pF 50V K
C1651	NCB21HK-103X	C CAP.	0.01 μ F 50V K
C1652	QETNLCH-107Z	E CAP.	100 μ F 16V M
C1653	QETNLEM-476Z	E CAP.	47 μ F 25V M
C1654	QFLCLHJ-104Z	M CAP.	0.1 μ F 50V J
C1655	QENCLHM-475Z	BP E CAP.	4.7 μ F 50V M
C1656	QENCLHM-105Z	E CAP.	1 μ F 50V M
C1657	QETNLHM-225Z	E CAP.	2.2 μ F 50V M
C1658	NCB21HK-473X	C CAP.	0.047 μ F 50V K
C1659	QETNLHM-474Z	E CAP.	0.47 μ F 50V M
C1660-61	QFLCLHJ-104Z	M CAP.	0.1 μ F 50V J
C1662	QBTCLCK-335Z	TAN.CAP.	3.3 μ F 16V K
C1663	QETNLHM-105Z	E CAP.	1 μ F 50V M
C1664	QBTCLCK-106Z	TAN.CAP.	10 μ F 16V K
C1665-66	QETNLHM-105Z	E CAP.	1 μ F 50V M
C1667	QETNLHM-336Z	E CAP.	33 μ F 50V M
C1668	QETNLHM-105Z	E CAP.	1 μ F 50V M
C1669-70	QENCLHM-105Z	E CAP.	1 μ F 50V M
C1671	QETNLHM-225Z	E CAP.	2.2 μ F 50V M
C1672	NCB21HK-222X	C CAP.	2200pF 50V K
C1673	QFLCLHJ-104Z	M CAP.	0.1 μ F 50V J
C1674	QETNLHM-225Z	E CAP.	2.2 μ F 50V M
C1675	NCB21HK-222X	C CAP.	2200pF 50V K
C1676	QFLCLHJ-104Z	M CAP.	0.1 μ F 50V J
C1677	NCB21HK-223X	C CAP.	0.022 μ F 50V K
C1679	QETNLHM-105Z	E CAP.	1 μ F 50V M
C1680	QETNLEM-476Z	E CAP.	47 μ F 25V M
C1682-83	QETNLHM-475Z	E CAP.	4.7 μ F 50V M
C1684-86	QETNLHM-106Z	E CAP.	10 μ F 50V M

△ Symbol No.	Part No.	Part Name	Description
CAPACITOR			
C1691-92	QETNLHM-106Z	E CAP.	10 μ F 50V M
C1693-94	NCB21HK-392X	C CAP.	3900pF 50V K
C1701	NDC21HJ-102X	C CAP.	1000pF 50V J
C1703	NCB21HK-102X	C CAP.	1000pF 50V K
C1704	NCB21HK-103X	C CAP.	0.01 μ F 50V K
C1705	NDC21HJ-471X	C CAP.	470pF 50V J
C1706	QFLCLHJ-104Z	M CAP.	0.1 μ F 50V J
C1707	NDC21HJ-180X	C CAP.	18pF 50V J
C1708	NDC21HJ-220X	C CAP.	22pF 50V J
C1709	QETNLEM-476Z	E CAP.	47 μ F 25V M
C1710	QFLCLHJ-104Z	M CAP.	0.1 μ F 50V J
C1711	NCB21HK-103X	C CAP.	0.01 μ F 50V K
C1712-13	QETNLCH-107Z	E CAP.	100 μ F 16V M
C1714	QFLCLHJ-104Z	M CAP.	0.1 μ F 50V J
C1715	NDC21HJ-150X	C CAP.	150pF 50V J
C1716	NDC21HJ-390X	C CAP.	39pF 50V J
C1717	NDC21HJ-151X	C CAP.	150pF 50V J
C1718	NRS402J-OROX	MG R.	0.02 1/10W J
C1719	QETNLHM-106Z	E CAP.	10 μ F 50V M
C1720	NDC21HJ-151X	C CAP.	150pF 50V J
C1722	NCB21HK-103X	C CAP.	0.01 μ F 50V K
C1761	QETNLHM-105Z	E CAP.	1 μ F 50V M
C1762	NDC21HJ-221X	C CAP.	220pF 50V J
C1763	NCB21HK-102X	C CAP.	1000pF 50V K
C1765	NDC21HJ-101X	C CAP.	100pF 50V J
C1766	QENCLHM-474Z	BP E CAP.	0.47 μ F 50V M
C1771	QETNLEM-476Z	E CAP.	47 μ F 25V M
C1772	NCB21HK-103X	C CAP.	0.01 μ F 50V K
C1773	QETNLHM-105Z	E CAP.	1 μ F 50V M
C1779	NDC21HJ-100X	C CAP.	10pF 50V J
C1780	NRS402J-OROX	MG R.	0.02 1/10W J
C1781	NRS402J-OROX	MG R.	0.02 1/10W J
C1805	QETNLCH-227Z	E CAP.	220 μ F 16V M
C1806	NCB21HK-103X	C CAP.	0.01 μ F 50V K
C1811-13	NCB21HK-103X	C CAP.	0.01 μ F 50V K
△ C1901	QFZ9072-104	MF CAP.	0.1 μ FAC275V K
△ C1902	QFZ9072-104	MF CAP.	0.1 μ FAC275V K
△ C1903	QCZ9074-472	C CAP.	4700pFAC250V M
△ C1904	QCZ9074-472	C CAP.	4700pFAC250V M
△ C1905	QCZ9074-472	C CAP.	4700pFAC250V M
△ C1906	QEZO071-337	E CAP.	330 μ F 400V M
C1921	QCZ025-222	C CAP.	2200pF 2kV K
C1924	QETNLVM-477Z	E CAP.	470 μ F 35V M
C1925	QFN31HJ-102Z	M CAP.	1000pF 50V J
C1926	QFN31HJ-222Z	M CAP.	2200pF 50V J
C1928	QFLCLHJ-104Z	M CAP.	0.1 μ F 50V J
C1931	QCZ0122-391	C CAP.	390pF 2kV K
C1941	QCZ025-561	C CAP.	560pF 2kV K
△ C1942	QEZO03-107	E CAP.	100 μ F 160V M
C1943	QCB32HK-561Z	C CAP.	560pF 500V K
C1944	QETNLCH-477Z	E CAP.	470 μ F 16V M
C1945	QETNLCH-108Z	E CAP.	1000 μ F 16V M
C1946	QETNLEM-107Z	E CAP.	100 μ F 25V M
C1947	QETNLHM-106Z	E CAP.	10 μ F 50V M
C1952	QETNLEM-108Z	E CAP.	1000 μ F 25V M
C1953	QCZ0122-561	C CAP.	560pF 2kV K
C1957	QCB31HK-471Z	C CAP.	470pF 50V K
C1961	QETNLCH-107Z	E CAP.	100 μ F 16V M
C1962	QETNLHM-476Z	E CAP.	47 μ F 50V M
△ C1981	QCZ9075-471	C CAP.	470pFAC250V K
△ C1982	QCZ9075-222	C CAP.	2200pFAC250V M
△ C1983	QCZ9075-471	C CAP.	470pFAC250V K
TRANSFORMER			
T1111	CELTD01-209J3	C.WAVE TRANSF.	
T1521	CE42034-002	H.DRIVE TRANSF.	
△ T1522	QQH015-001	H.V.TRANSF.	
△ T1921	CETS090-001J8	SWITCH.TRANSF.	

△ Symbol No.	Part No.	Part Name	Description
COIL			
L1001	QQL244J-150Z	PEAKING COIL	
L1008	QQL244J-4R7Z	PEAKING COIL	
L1101	QQL2014-R2Z	PEAKING COIL	
L1131	QQL244J-220Z	PEAKING COIL	
L1161	QQL244J-220Z	PEAKING COIL	
L1205	QQL244J-4R7Z	PEAKING COIL	
L1301	QQL244J-390Z	PEAKING COIL	
L1381	QQL244J-390Z	PEAKING COIL	
△ L1501	QQL244J-4R7Z	PEAKING COIL	
L1521	QQR1137-00Z	LINEARITY COIL	
L1701-02	QQL244J-4R7Z	PEAKING COIL	
L1704	QQL39BK-8R2Z	COIL	8.2μH K
L1771	QQL244J-4R7Z	PEAKING COIL	
L1941-42	QQL26AK-820Z	COIL	82μH K

Symbol No.	Part No.	Part Name	Description
DIODE			
D1001	MTZJ33A-T2	ZENER DIODE	
D1201	1S5B3-T2	SI. DIODE	
D1202	MTZJ7.5B-T2	ZENER DIODE	
D1253-56	MTZJ9.1C-T2	ZENER DIODE	
D1341	1S5B3-T2	SI. DIODE	
D1401	1N4003-T2	SI. DIODE	
D1402	MTZJ7.5-T2	ZENER DIODE	
D1510	1S5B3-T2	SI. DIODE	
D1512	RH3G-F1	SI. DIODE	
D1541	RH1S-T3	SI. DIODE	
△ D1542	RU3AM-LFC4	SI. DIODE	
△ D1543	RGP10J-5025-T3	SI. DIODE	
D1544	RH1S-T3	SI. DIODE	
D1561	1S581-T2	SI. DIODE	
△ D1562	MTZJ7.5S-T2	ZENER DIODE	
△ D1581	RGP10J-5025-T3	SI. DIODE	
D1582	MTZJ9.1B-T2	ZENER DIODE	
D1631	1S5B3-T2	SI. DIODE	
D1632	1S5B3-T2	SI. DIODE	
D1633	1S5B3-T2	SI. DIODE	
D1634	1S5B3-T2	SI. DIODE	
D1656-57	MTZJ9.1C-T2	ZENER DIODE	
D1691-92	MTZJ9.1C-T2	ZENER DIODE	
D1701	1S5B3-T2	SI. DIODE	
D1708	1S5B3-T2	SI. DIODE	
D1704	1S5B3-T2	SI. DIODE	
D1710	MTZJ5.6A-T2	ZENER DIODE	
D1712	1S5B3-T2	SI. DIODE	
D1713	1S5B3-T2	SI. DIODE	
D1771-72	MTZJ5.6A-T2	ZENER DIODE	
D1801-03	MTZJ15B-T2	ZENER DIODE	
D1805	MTZJ15B-T2	ZENER DIODE	
△ D1901	GSI8460	DIODE	
△ D1903	RGP10J-5025-T3	SI. DIODE	
D1905	MTZJ6.8A-T2	ZENER DIODE	
△ D1921	RGP10J-5025-T3	SI. DIODE	
△ D1922	RGP10J-5025-T3	SI. DIODE	
D1923	MTZJ15A-T2	ZENER DIODE	
D1924	1S5B3-T2	SI. DIODE	
D1927	1S5B3-T2	SI. DIODE	
D1928	1S5B3-T2	SI. DIODE	
D1929	MTZJ15A-T2	ZENER DIODE	
D1941	RU3AM-LFC4	SI. DIODE	
△ D1942	RGP10J-5025-T3	SI. DIODE	
D1943	1S5B3-T2	SI. DIODE	
D1945	MTZJ5.1B-T2	ZENER DIODE	
D1948	RU3Y-LFC4	SI. DIODE	
D1961	MTZJ7.5A-T2	ZENER DIODE	
D1962	1S5B3-T2	SI. DIODE	

Symbol No.	Part No.	Part Name	Description
TRANSISTOR			
Q1101	2SC5083/L-P/-T	SI. TRANSISTOR	
Q1131	2SC2412K/QR/-X	SI. TRANSISTOR	
Q1161	2SC2412K/QR/-X	SI. TRANSISTOR	
Q1201-02	2SC2412K/QR/-X	SI. TRANSISTOR	
Q1301-02	2SC2412K/QR/-X	SI. TRANSISTOR	
Q1341-42	2SC2412K/QR/-X	SI. TRANSISTOR	
Q1351-53	2SC4544-LB	SI. TRANSISTOR	

△ Symbol No.	Part No.	Part Name	Description
TRANSISTOR			
Q1401	2SC2412K/QR/-X	SI. TRANSISTOR	
△ Q1511	2SC2785/JH/-T	SI. TRANSISTOR	
Q1521	BSN304-T	F. E. T.	
△ Q1522	2SD2499-LB	SI. TRANSISTOR	H. OUT
Q1601	2SC2412K/QR/-X	SI. TRANSISTOR	
Q1608	DTC124EKA-X	DIGI. TRANSISTOR	
Q1604-05	DTC323TK-X	DIGI. TRANSISTOR	
Q1631	2SA1037AK/QR/-X	SI. TRANSISTOR	
Q1651-54	DTC323TK-X	DIGI. TRANSISTOR	
Q1701-02	2SC2412K/QR/-X	SI. TRANSISTOR	
Q1703	DTC124EKA-X	DIGI. TRANSISTOR	
Q1761	2SC2412K/QR/-X	SI. TRANSISTOR	
Q1921	2SA933AS/QR/-T	SI. TRANSISTOR	
Q1941	2SA966/OY/-T	SI. TRANSISTOR	
Q1942-44	2SC2412K/QR/-X	SI. TRANSISTOR	
Q1961	2SA949/Y/Z1-T	SI. TRANSISTOR	

Symbol No.	Part No.	Part Name	Description
IC			
IC1001	AN7805F	I. C (MONO-ANA)	
IC1101	M52342SP	I. C (MONO-ANA)	
IC1201	TB1230N	I. C (DIGI-OTHER)	
IC1251	BA7612N	I. C (MONO-ANA)	
IC1291	AN7805	I. C (M)	
IC1292	AN78L09-T	I. C (MONO-ANA)	
IC1293	AN78L05-T	I. C (MONO-ANA)	
IC1401	LA7840	I. C (MONO-ANA)	
IC1541	AN7809F	I. C (MONO-ANA)	
△ IC1601	LA4485	I. C (MONO-ANA)	
IC1651	UPC1851BCU	I. C (MONO-ANA)	
IC1652	BA15218N	I. C (MONO-ANA)	
IC1701	M37267M8-100SP	I. C	
IC1702	AT24C02-T2922AR	I. C	(SERVICE)
IC1703	L78LR05E-MA	I. C (MONO-ANA)	
△ IC1921	STR-F6654	I. C (HYBRID)	
△ IC1941	SE130N	I. C (H)	

Symbol No.	Part No.	Part Name	Description
OTHERS			
CF1001	QAX0349-001	CERAMIC FILTER	
CF1131	QAX0339-001	CERAMIC FILTER	
CF1161	SF5H.5MCB	CERAMIC FILTER	
CL1002	QZW0028-002	WIRE CLAMP	
△ CP1941	ICP-N75-Y	I. C. PROTECT	
△ CP1942	ICP-N50-Y	I. C. PROTECT	
△ EF1301	CE42142-222Z	EMI FILTER	
△ F1901	QMF51E2-3R15J4	FUSE	3.15A
FC1901	CEM002-001Z	FUSE CLIP	
FC1902	CEM002-001Z	FUSE CLIP	
△ FR1542	QRZ9024-R56	F R	0.56 Ω 2W K
△ FR1543	QRZ9023-2R2	F R	2.2 Ω 2W J
△ FR1561	QRZ9017-4R7	F R	4.7 Ω 1/4W J
△ FR1585	QRZ9021-2R2	F R	2.2 Ω 1/2W J
△ FR1586	QRE121J-682Y	C R	6.8kΩ 1/2W J
J1001	QNN0086-001	PIN JACK	
K1401	QQR0621-001Z	BEADS CORE	
K1921	QQR0582-001Z	BEADS CORE	
K1923	QQR0582-001Z	BEADS CORE	
K1941-43	QQR0582-001Z	BEADS CORE	
△ LF1901	QQR0676-001	LINE FILTER	
△ PC1921	TLP621/GR/	I. C (PH. COUPLER)	
SF1101	QAX0324-002	SAW FILTER	
SK1351	CE42535-001J1	C. R. T. SOCKET	
△ TH1901	QAD0101-9R0	P. THERMISTOR	
△ TH1902	QAD0101-9R0	P. THERMISTOR	
△ TU1001	QAU0229-001	TUNER	
△ VA1901	ERZV10V621CS	VARIABLE CAPACITOR	
X1301	QAX0305-001Z	CRYSTAL	
X1701	QAX0468-001Z	CRYSTAL	

**FRONT CONTROL PW BOARD ASS'Y
(SGA-4005A-R2)**

Symbol No.	Part No.	Part Name	Description
RESISTOR			
R4701	QRE121J-103Y	C R	10kΩ 1/2W J
R4702	QRE121J-562Y	C R	5.6kΩ 1/2W J
R4703-04	QRE121J-103Y	C R	10kΩ 1/2W J
R4705	QRE121J-562Y	C R	5.6kΩ 1/2W J
R4706	QRE121J-103Y	C R	10kΩ 1/2W J
R4707-08	QRE121J-223Y	C R	22kΩ 1/2W J
R4709	QRE121J-561Y	C R	560Ω 1/2W J
R4710-11	QRE121J-223Y	C R	22kΩ 1/2W J
R4712	QRE121J-561Y	C R	560Ω 1/2W J
R4713	QRE121J-103Y	C R	10kΩ 1/2W J
CAPACITOR			
C4701	QETNLEM-476Z	E CAP.	47μF 25V M
C4702	QCB32HK-561Z	C CAP.	560pF 500V K
COIL			
L4701	QQL08BJ-560Z	COIL	56μH J
DIODE			
D4702	SPR-39MWWF	L.E.D.	
TRANSISTOR			
Q4701	2SA983S(QR)-T	SI. TRANSISTOR	
Q4702	2SC1740S(QR)/-T	SI. TRANSISTOR	
IC			
IC4701	PIC-37243SR	IR DETECT UNIT	
OTHERS			
S4701	LC30190-001B-A	L.E.D. HOLDER	
S4702	QSW0619-003Z	PUSH SWITCH	VOL+
S4703	QSW0619-003Z	PUSH SWITCH	VOL-
S4704	QSW0619-003Z	PUSH SWITCH	CH+
S4705	QSW0619-003Z	PUSH SWITCH	CH-
△ S4901	QSP4K21-C01	PUSH SWITCH	MENU POWER

REMOTE CONTROL UNIT PARTS LIST (RM-C363-1H)

△ Ref.No.	Part No.	Part Name	Description
	25-1168 B	BATTERY COVER	(RM-C363-1H)

PACKING

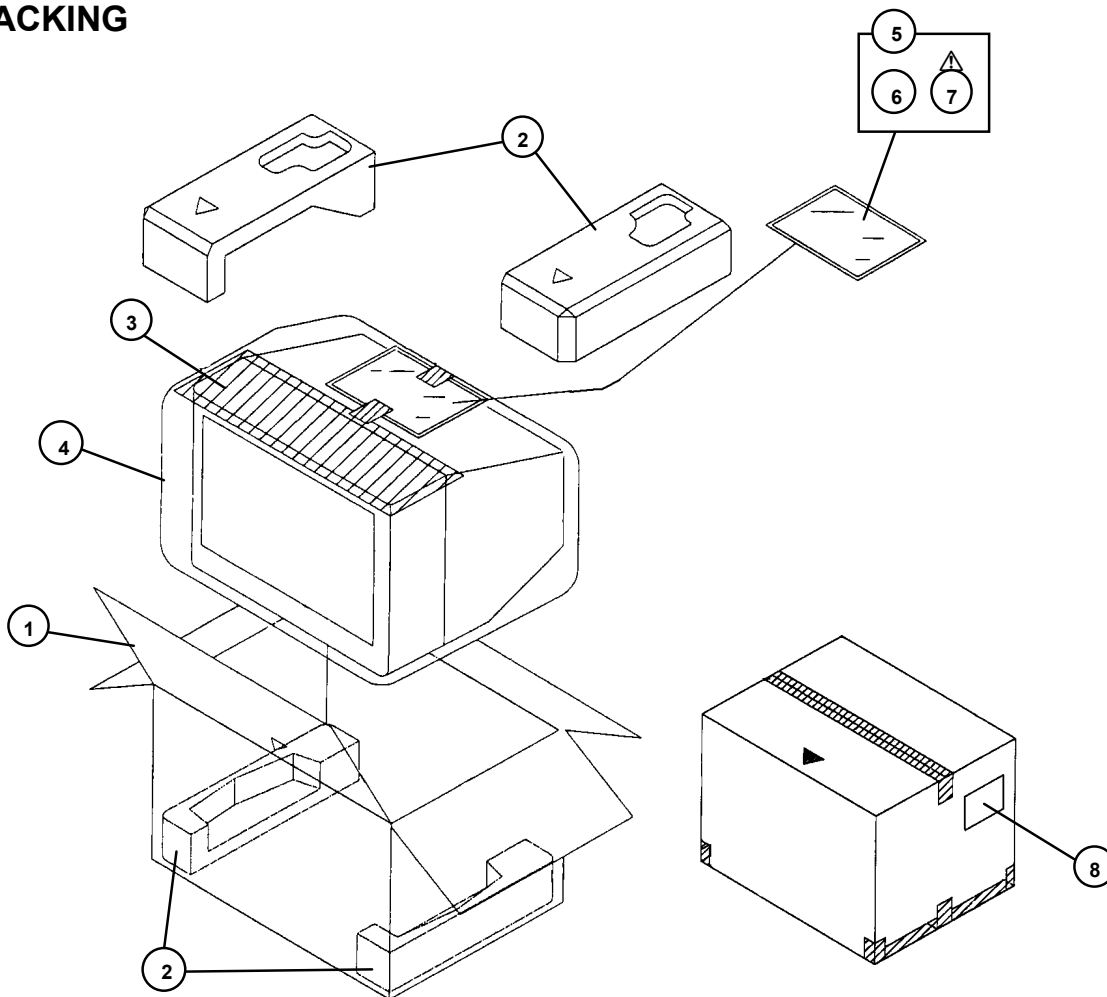

PACKING PARTS LIST

△ Ref.No.	Part No.	Part Name	Description
1	LC10058-017A	PACKING CASE	4pcs in 1set
2	LC10774-002A-D	CUSHION ASSY	
3	CP30899-001-R	TOP COVER	
4	CP30897-004-R	POLY BAG	
5	CP30897-001-R	POLY BAG	
6	RM-C363-1H	REMOCON UNIT	
△ 7	LCT1100-001A-D	INST BOOK	
8	CM36242-012-R	POS LABEL	

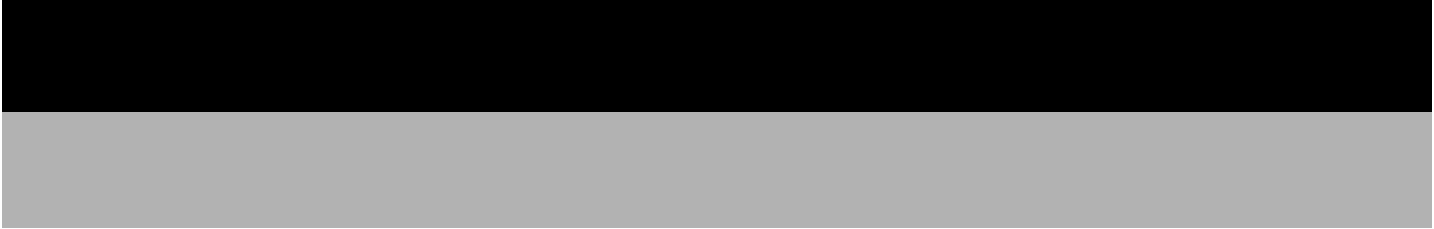

JVC

VICTOR COMPANY OF JAPAN, LIMITED
HOME AV NETWORK BUSINESS UNIT 12, 3-chome, Moriya-cho, Kanagawa-ku, Yokohama, Kanagawa-prefecture, 221-8528, Japan

T2922AR-CK #3



Printed in Japan
VP 0203
DP3051

FRONT CONTROL PWB PATTERN

AV-T2922/AR STANDARD CIRCUIT DIAGRAM

NOTE ON USING CIRCUIT DIAGRAMS

1. SAFETY

The components identified by the Δ symbol and shading are critical for safety. For continued safety replace safety critical components only with manufactures recommended parts.

2. SPECIFIED VOLTAGE AND WAVEFORM VALUES

The voltage and waveform values have been measured under the following conditions.

- (1) Input signal : Colour bar signal
- (2) Setting positions of each knob/button and variable resistor : Original setting position when shipped
- (3) Internal resistance of tester : DC 20k Ω /V
- (4) Oscilloscope sweeping time : H \Rightarrow 20 μ S/div
: V \Rightarrow 5mS/div
: Others \Rightarrow Sweeping time is specified
- (5) Voltage values : All DC voltage values

* Since the voltage values of signal circuit vary to some extent according to adjustments, use them as reference values.

3. INDICATION OF PARTS SYMBOL [EXAMPLE]

- In the PW board : R1209 \rightarrow R209

4. INDICATIONS ON THE CIRCUIT DIAGRAM

(1) Resistors

● Resistance value

- No unit : { Ω }
- K : {K Ω }
- M : {M Ω }

● Rated allowable power

- No indication : 1/16 [W]
- Others : As specified

● Type

- No indication : Carbon resistor
- OMR : Oxide metal film resistor
- MFR : Metal film resistor
- MPR : Metal plate resistor
- UNFR : Uninflamable resistor
- FR : Fusible resistor

* Composition resistor 1/2 [W] is specified as 1/2S or Comp.

(2) Capacitors

● Capacitance value

- 1 or higher : [pF]
- less than 1 : [μ F]

● Withstand voltage

- No indication : DC50[V]
- Others : DC withstand voltage [V]
- AC indicated : AC withstand voltage [V]

* Electrolytic Capacitors
4750[Example]:Capacitance value [μ F]/withstand voltage[V]

● Type

- No indication : Ceramic capacitor
- MM : Metalized mylar capacitor
- PP : Polypropylene capacitor
- MPP : Metalized polypropylene capacitor
- MF : Metalized film capacitor
- TF : Thin film capacitor
- BP : Bipolar electrolytic capacitor
- TAN : Tantalum capacitor

(3) Coils

- No unit : {H}
- Others : As specified

(4) Power Supply

- No unit : B1
- Others : B2 (12V)
- :9V
- :5V

* Respective voltage values are indicated

(5) Test point

- : Test point
- : Only test point display

(6) Connecting method

- : Connector
- : Wrapping or soldering
- \rightarrow : Receptacle

(7) Ground symbol

- \perp : LIVE side ground
- \downarrow : ISOLATED(NEUTRAL) side ground
- \oplus : EARTH ground
- ∇ : DIGITAL ground

5. NOTE FOR REPAIRING SERVICE

This model's power circuit is partly different in the GND. The difference of the GND is shown by the LIVE (\perp) side GND and the ISOLATED(NEUTRAL) (\downarrow) side GND. Therefore, care must be taken for the following points.

- (1) Do not touch the LIVE side GND or the LIVE side GND and the ISOLATED(NEUTRAL) side GND simultaneously. If the above caution is not respected, an electric shock may be caused. Therefore, make sure that the power cord is surely removed from the receptacle when, for example, the chassis is pulled out.
- (2) Do not short between the LIVE side GND and ISOLATED(NEUTRAL) side GND or never measure with a measuring apparatus measure with a measuring apparatus (oscilloscope, etc.) the LIVE side GND and ISOLATED(NEUTRAL) side GND at the same time. If the above precaution is not respected, a fuse or any parts will be broken.

◇ Since the circuit diagram is a standard one, the circuit and circuit constants may be subject to change for improvement without any notice.

NOTE

◇ Due improvement in performance, some part numbers show in the circuit diagram may not agree with those indicated in the part list.
When ordering parts, please use the numbers that appear in the Parts List.

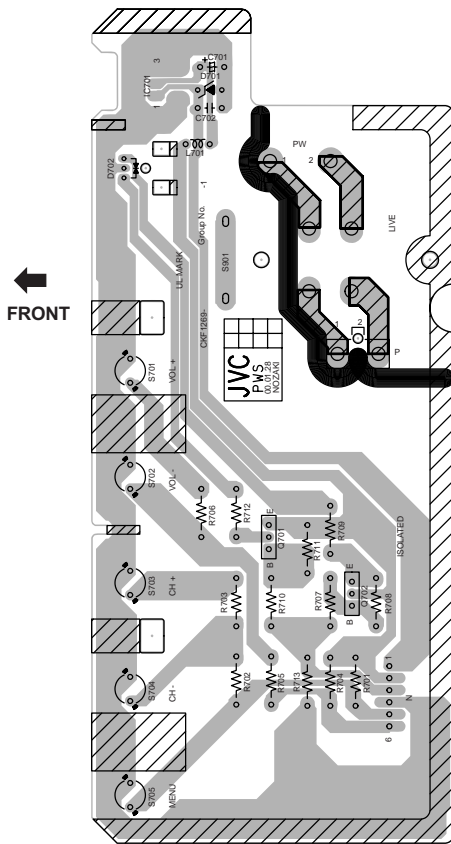

CONTENTS

SEMICONDUCTOR SHAPES 2-2

BLOCK DIAGRAM 2-3

CIRCUIT DIAGRAMS

 MAIN & FRONT CONTROL PWB CIRCUIT DIAGRAM 2-5

 MAIN & CRT SOCKET PWB CIRCUIT DIAGRAM 2-7

PATTERN DIAGRAMS

 MAIN PWB PATTERN 2-9

 CRT SOCKET PWB PATTERN 2-11

 FRONT CONTROL PWB PATTERN 2-12

CRT SOCKET PWB PATTERN

SEMICONDUCTOR SHAPES

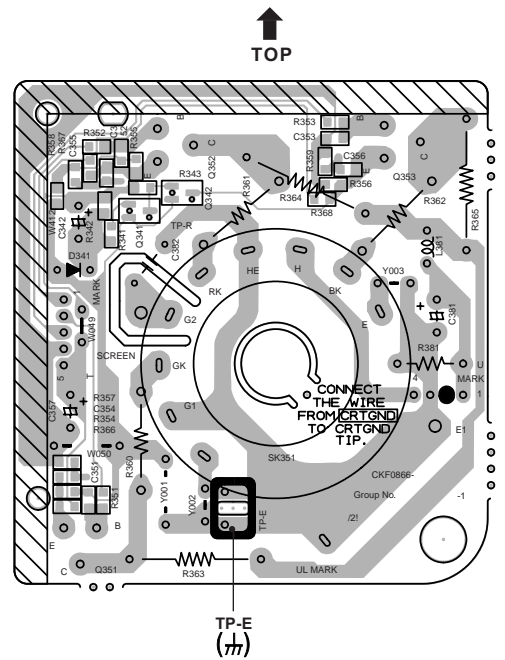
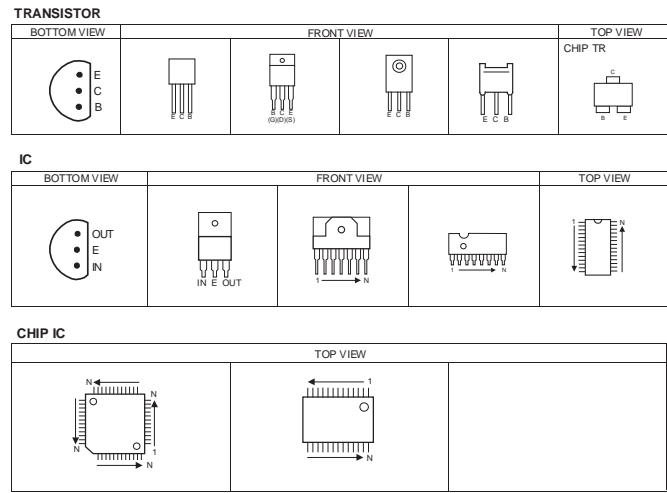

BLOCK DIAGRAM

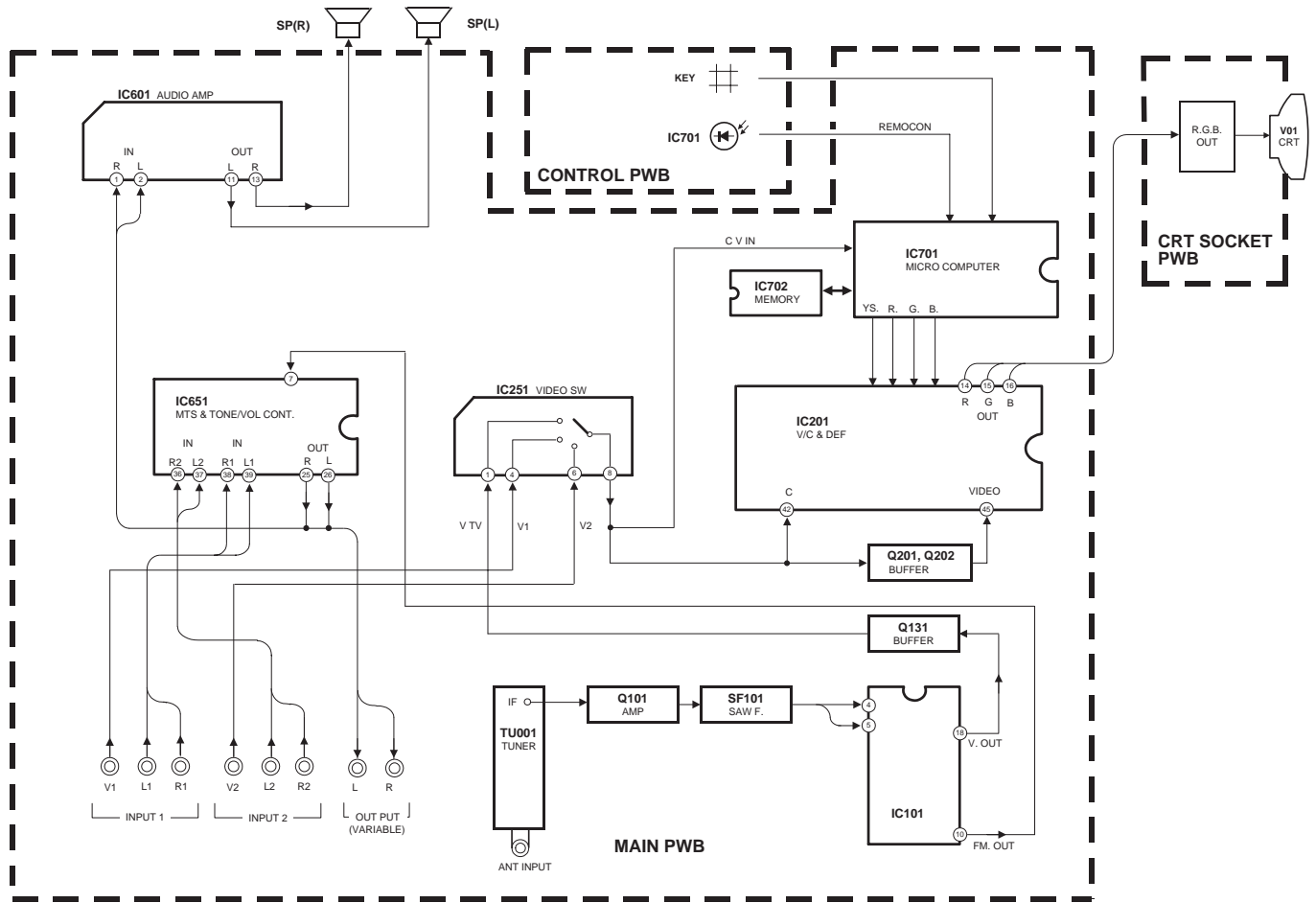

No.51917

2-3

2-4

No.51917

CIRCUIT DIAGRAMS MAIN & FRONT CONTROL PWB CIRCUIT DIAGRAM

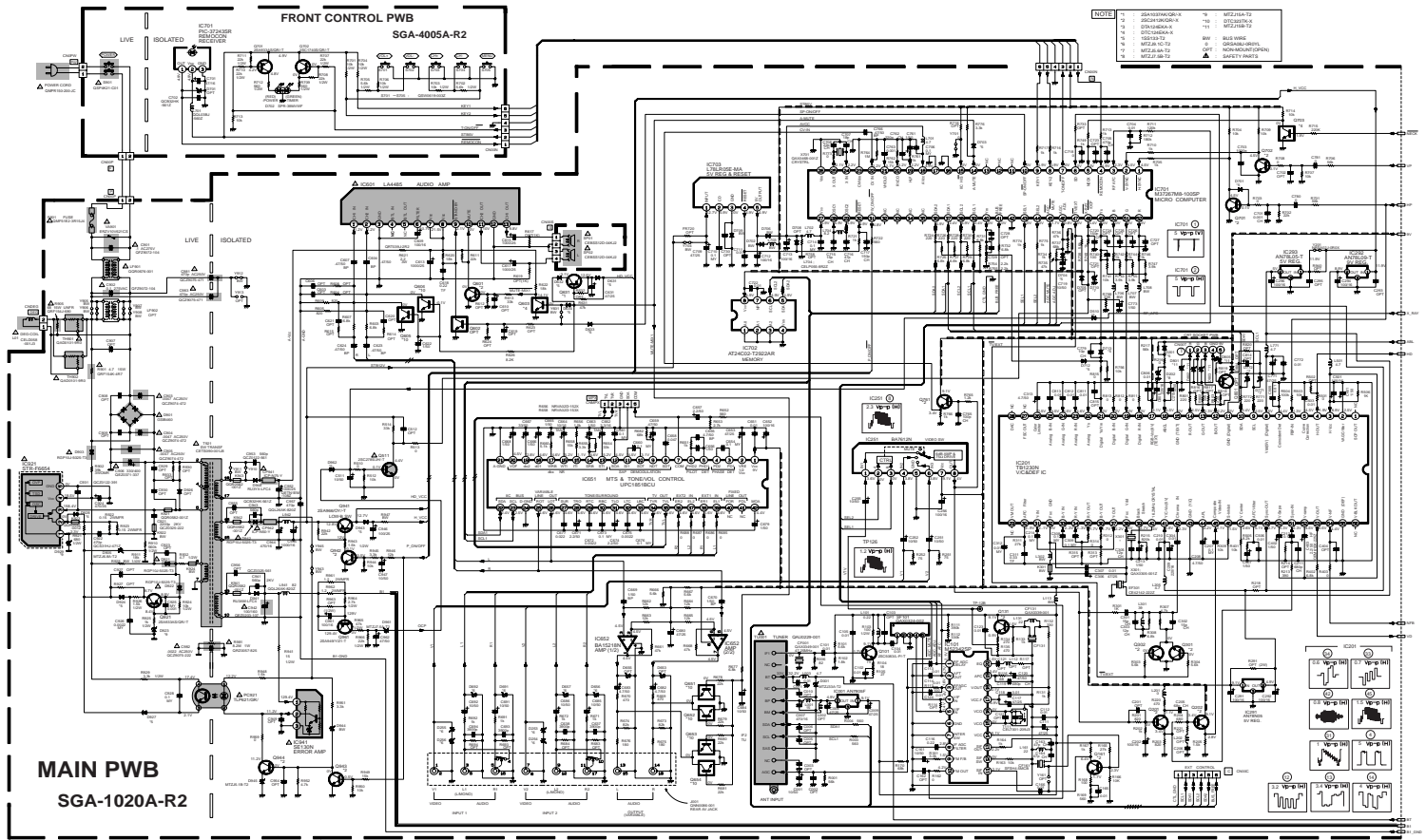

PATTERN DIAGRAMS MAIN PWB PATTERN

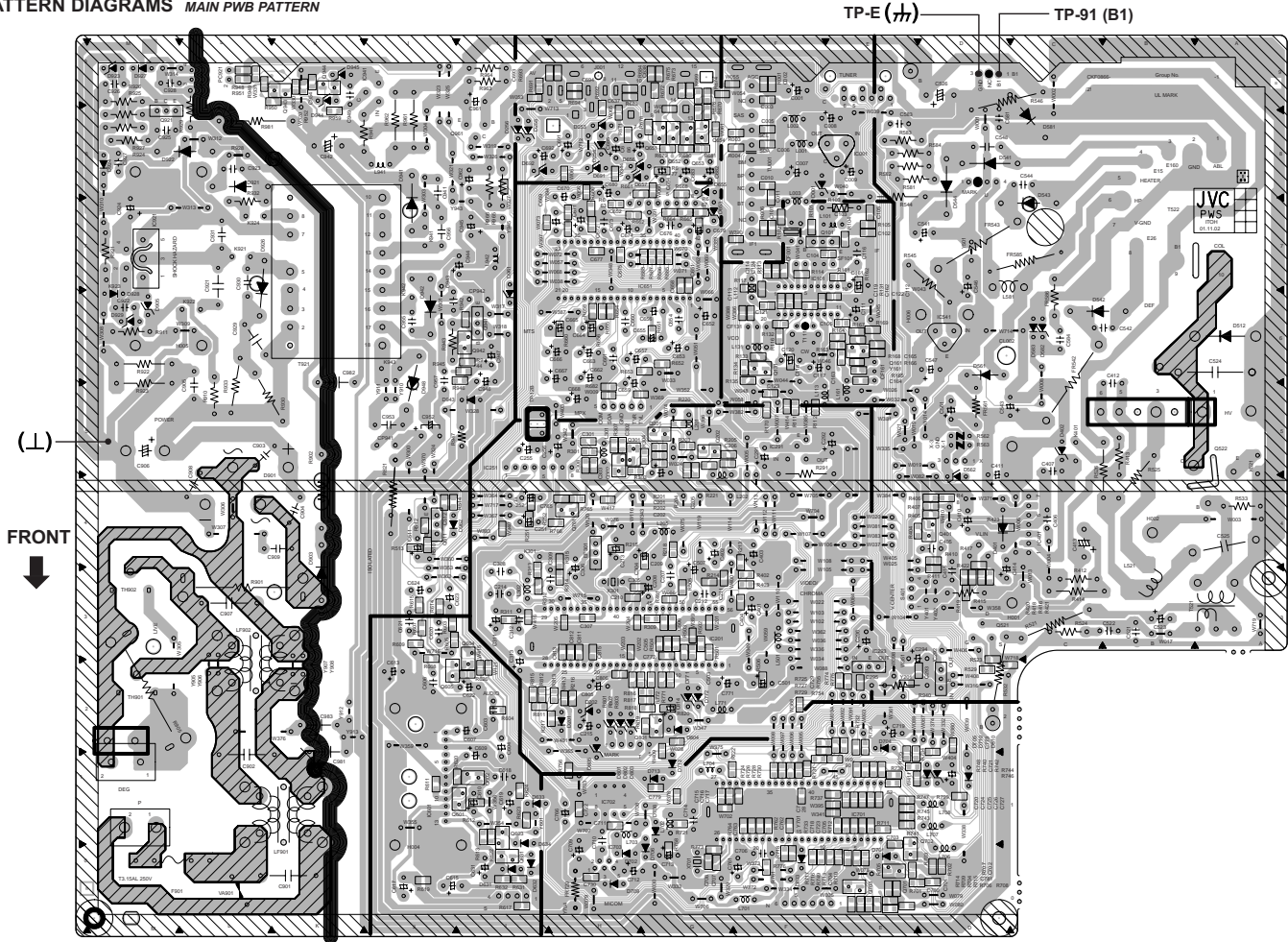

No.51917

2-9

2-10

No.51917