

JVC AV-T2122 SERVICE MANUAL

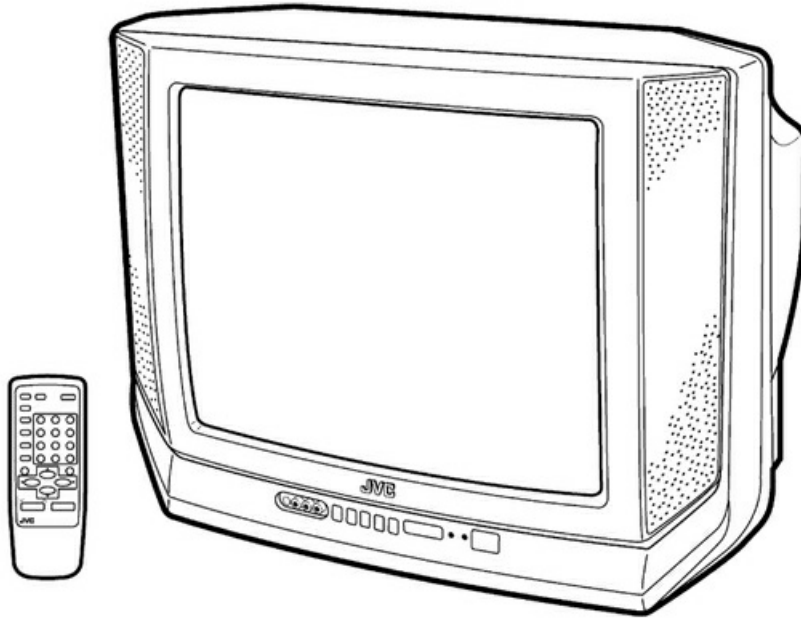

Quick Links

[Parts List](#)

Table of Contents

[service adjustments](#)

[adjustment items](#)

[main pwb](#)

[initial setting value of service menu](#)

[sound mode](#)

[replacement of chip component](#)

[block diagram](#)

[parts list](#)

[exploded view](#)

[exploded view parts list](#)

[Other ManualsLib Projects](#)

JVC

SERVICE MANUAL

COLOR TELEVISION

BASIC CHASSIS

GA2

AV-T2122/AR

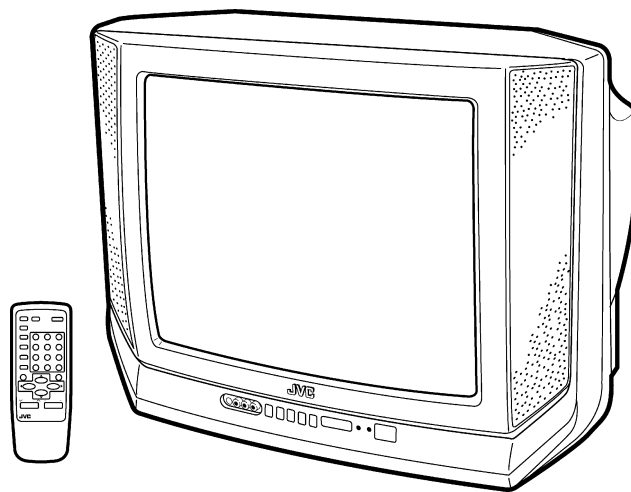

CONTENTS

■ SPECIFICATIONS	2
■ SAFETY PRECAUTIONS	3
■ FEATURES	4
■ FUNCTIONS	4
■ SPECIFIC SERVICE INSTRUCTIONS	6
■ SERVICE ADJUSTMENTS	10
■ PARTS LIST	29
★ OPERATING INSTRUCTIONS	
★ STANDARD CIRCUIT DIAGRAM (APPENDIX)	2-1

MEMORY IC REPLACEMENT

1. Memory IC

This model uses a memory IC.
 The memory IC stores data for proper operation of video and deflection circuits.
 When replacing, be sure to use an IC containing this (initial value) data.

2. Memory IC replacement procedure

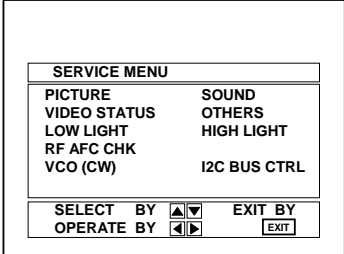
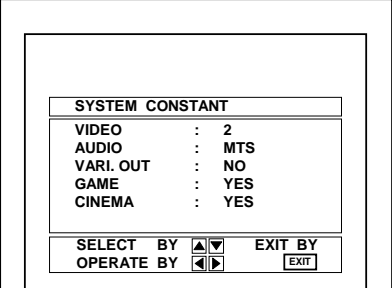
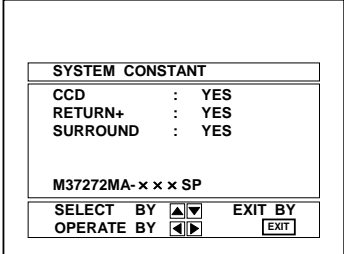
PROCEDURE	SCREEN DISPLAY
<p>(1) Power off</p> <p>Switch off the power and disconnect the power cord from the wall outlet.</p>	
<p>(2) Replace the memory IC.</p> <p>Be sure to use memory ICs written with the initial data values.</p>	
<p>(3) Power on</p> <p>Connect the power cord to the wall outlet and switch on the power.</p>	
<p>(4) System constant check and setting</p> <ol style="list-style-type: none"> 1) Simultaneously press the DISPLAY key and VIDEO STATUS key of the remote control unit. 2) The SERVICE MENU screen of Fig.1 is displayed. 3) While the SERVICE MENU is displayed, again simultaneously press the DISPLAY and VIDEO STATUS keys to display the Fig.2 SYSTEM CONSTANT screen. 4) Refer to the SYSTEM CONSTANT table and check the setting items. Where these differ, select the setting item with the MENU UP / DOWN key and adjust the setting with the MENU LEFT / RIGHT keys. (The letters of the selected item are displayed in yellow.) 5) After adjusting, release the MENU LEFT / RIGHT key to store the setting value. 6) Press the EXIT key twice to return the normal screen. 	<div style="text-align: center;">  <p>Fig.1</p> </div> <div style="text-align: center;">  </div> <div style="text-align: center;">  <p>Fig.2</p> </div>
<p>(5) Receive channel setting</p> <p>Refer to the OPERATING INSTRUCTIONS (USER' S GUIDE) and set the receive channels (Channels Preset) as described.</p>	
<p>(6) User settings</p> <p>Check the user setting items according to Table 2-1 and 2-2. Where these do not agree, refer to the OPERATING INSTRUCTIONS (USER' S GUIDE) and set the items as described.</p>	
<p>(7) SERVICE MENU setting</p> <p>Verify what to set in the SERVICE MENU, and set whatever is necessary. (Fig.1) Refer to the SERVICE ADJUSTMENT for setting.</p>	

SETTING OF SYSTEM CONSTANT SET

Setting item	Setting content	Setting value
VIDEO	<input type="checkbox"/> 1 <input checked="" type="checkbox"/> 2 <input type="checkbox"/>	2
AUDIO	<input type="checkbox"/> MONO <input type="checkbox"/> PH.MONO <input checked="" type="checkbox"/> MTS <input type="checkbox"/>	MTS
VARI. OUT	<input type="checkbox"/> YES <input checked="" type="checkbox"/> NO <input type="checkbox"/>	NO
GAME	<input type="checkbox"/> YES <input checked="" type="checkbox"/> NO <input type="checkbox"/>	YES
CINEMA	<input type="checkbox"/> YES <input checked="" type="checkbox"/> NO <input type="checkbox"/>	YES
CCD	<input type="checkbox"/> YES <input checked="" type="checkbox"/> NO <input type="checkbox"/>	YES
RETURN +	<input type="checkbox"/> YES <input checked="" type="checkbox"/> NO <input type="checkbox"/>	YES
SURROUND	<input type="checkbox"/> YES <input checked="" type="checkbox"/> NO <input type="checkbox"/>	YES

Table 1

USER SETTING VALUES**1.Setting of FUNCTION**

Setting item	Setting value	Setting item	Setting value
MAIN POWER	OFF	DISPLAY	OFF
SUB POWER	ON	SLEEP TIMER	0 MIN
CHANNEL	CH 02	VIDEO STATUS	ESTANDAR
CAPTION	OFF(CC1/T1)	PICTURE BOOSTER	OFF
VOLUME	10	COLOR SYSTEM	AUTO
TV/VIDEO	TV	HYPER SURROUND	OFF

Table 2-1

2.Setting of MENU

Setting item	Setting value	Setting item	Setting value
TINTE	ESTANDAR	ALTAVOCES	SI
COLOR	ESTANDAR	CHILD LOCK	NO
CONTRASTE	ESTANDAR	TEMPORIZADOR	NO
BRILLO	ESTANDAR	LISTA DE CANAIS	SET OPTIONALLY
DETALLE	ESTANDAR	AJUSTE CODIGO DE ACCESO	Unnecessary to Set
GRAVES	CENTER	PANTALLA AZUL	NO
AGUDOS	CENTER	FONDO NEGRO	SI (SIM)
BALANCE	CENTER	IDIOMA	ESP.
MTS	ESTÉREO	SUBTITULOS OCULTOS	NO(CC1/T1)

Table 2-2

SERVICE ADJUSTMENTS

ADJUSTMENT PREPARATION:

1. You can make the necessary adjustments for this unit with either the remote control unit or with the adjustment equipment and parts as given below.
2. Adjustment with the remote control unit is made on the basis of the initial setting values, however, the new setting values which set the screen to its optimum condition may differ from the initial settings.
3. Make sure that AC power is turned on correctly..
4. Turn on the power for the set and test equipment before use, and start the adjustment procedures after waiting at least 30 minutes
5. Unless otherwise specified, prepare the most suitable reception or input signal for adjustment.
6. Never touch any adjustment parts, which are not specified in the list for this adjustment-variable resistors, transformers, condensers, etc.
7. Presetting before adjustment.
Unless otherwise specified in the adjustment instructions, preset the following functions with the remote control unit.

VIDEO STATUS	ESTANDAR
GRAVES, AGUDOS, BALANCE	CENTER

ADJUSTMENT EQUIPMENT

1. DC voltmeter(or digital voltmeter)
2. Oscilloscope
3. Signal generator (Pattern generator) [NTSC-M] [PAL-M] [PAL-N]
4. Remote control unit
5. TV audio multiplex signal generator
6. Frequency counter

ADJUSTMENT ITEMS

- B1 POWER SUPPLY
- IF VCO adjustment
- RF AGC adjustment
- FOCUS adjustment
- DEFLECTION adjustment
 - V. HEIGHT, V. POSITION, V. LIN., V S CR adjustment
 - H. POSITION adjustment
- VIDEO / CHROMA adjustment
 - WHITE BALANCE (Low light) adjustment
 - WHITE BALANCE (High light) adjustment
 - SUB BRIGHT adjustment
 - SUB CONTRAST adjustment
 - SUB COLOR adjustment
 - SUB TINT adjustment
- MTS adjustment
 - INPUT LEVEL adjustment
 - STEREO VCO adjustment
 - SAP VCO adjustment
 - FILTER check
 - SEPARATION adjustment

ADJUSTMENT LOCATIONS

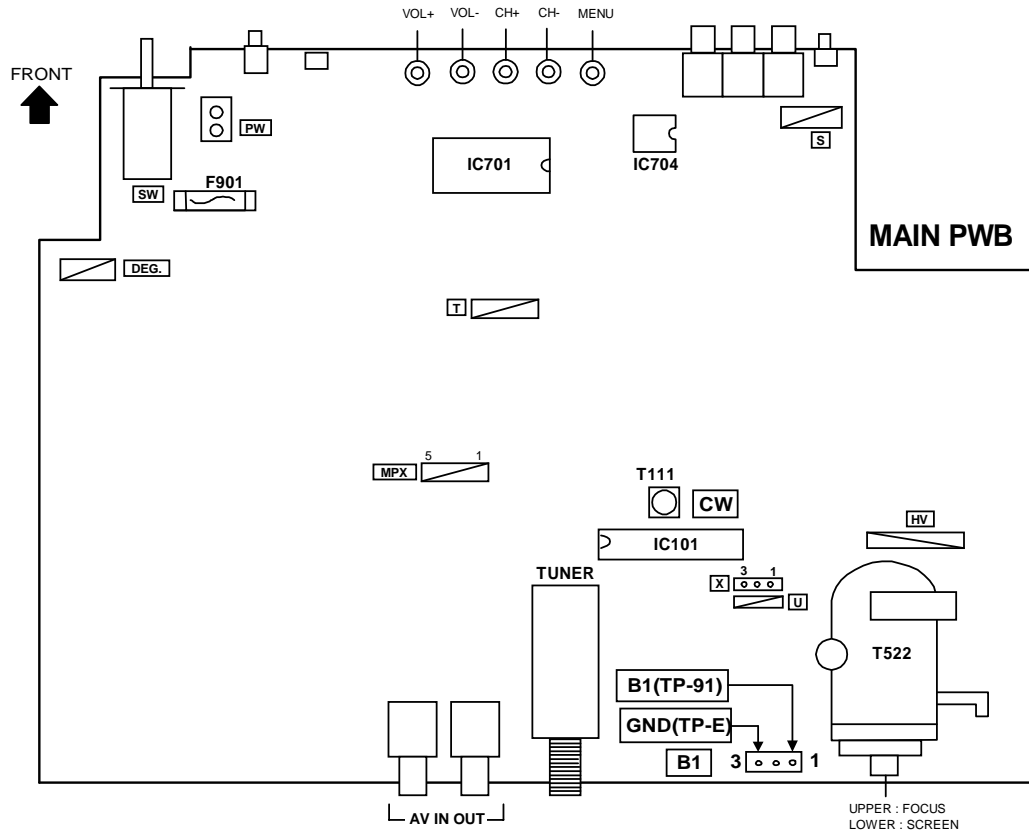

CRT SOCKET PWB (Within MAIN PWB ASS'Y)

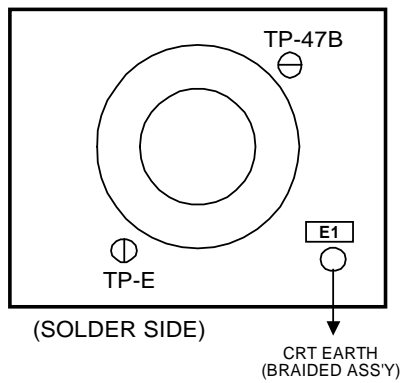

BASIC OPERATION OF SERVICE MENU

1. Operate the SERVICE MENU with the REMOTE CONTROL UNIT.

2. In general basic setting (adjustments) items or verifications are performed in the SERVICE MENU.

- (1) PICTURE This set the setting values (adjustment values) of the VIDEO/CHROMA and DEFLECTION circuits.
- (2) SOUND This set the setting values (adjustment values) of the AUDIO circuit.
- (3) VIDEO STATUS This is used when the THEATER and GAME MODE is adjusted.
- (4) OTHERS This is used when the OTHERS MODE is adjusted.
- (5) LOW LIGHT This sets the setting values (adjustment values) of the WHITE BALANCE circuit.
- (6) HIGH LIGHT This sets the setting values (adjustment values) of the WHITE BALANCE circuit.
- (7) RF AFC CHK This is used when the RF AFC CHK MODE is verified. **[Do not adjust]**
- (8) VCO (CW) This is used when the IF VCO is adjusted.
- (9) I²C BUS CTRL This is used when ON/OFF of the I²C BUS CTRL is set. **[Fixed ON]**

3. Basic Operations of the SERVICE MENU

(1) How to enter the SERVICE MENU.

Press the DISPLAY key and VIDEO STATUS key of the remote control unit at the same time to enter the SERVICE MENU screen ① shown in figure page later.

(2) SERVICE MENU screen selection

Press the UP / DOWN key of the MENU to select any of the following items.

(The letters of the selected items are displayed in yellow.)

- PICTURE
- SOUND
- VIDEO STATUS
- OTHERS
- LOW LIGHT
- HIGH LIGHT
- RF AFC CHK
- I²C BUS CTRL
- VCO (CW)

(3) Enter the any setting (adjustment) mode

● PICTURE, SOUND and OTHERS mode

- 1) If select any of PICTURE, SOUND or OTHERS items, and the LEFT / RIGHT key is pressed from SERVICE MENU (MAIN MENU), the screen ② will be displayed as shown in figure page later.
- 2) Then the UP / DOWN key is pressed, the PICTURE mode screen ③ or the SOUND mode screen ④ or the OTHERS mode screen ⑤ is displayed, and the PICTURE, SOUND or OTHERS setting can be performed.

● VIDEO STATUS, LOW LIGHT, HIGH LIGHT, RF AFC CHK, VCO (CW) and I²C BUS CTRL mode

- 1) If select any of VIDEO STATUS / LOW LIGHT / HIGH LIGHT / RF AFC CHK / VCO (CW) / I²C BUS CTRL items, and the LEFT / RIGHT key is pressed from SERVICE MENU (MAIN MENU), the screens ⑥ ⑦ ⑧ ⑨ ⑩ ⑪ will be displayed as shown in figure page later.
- 2) Then the settings or verifications can be performed.

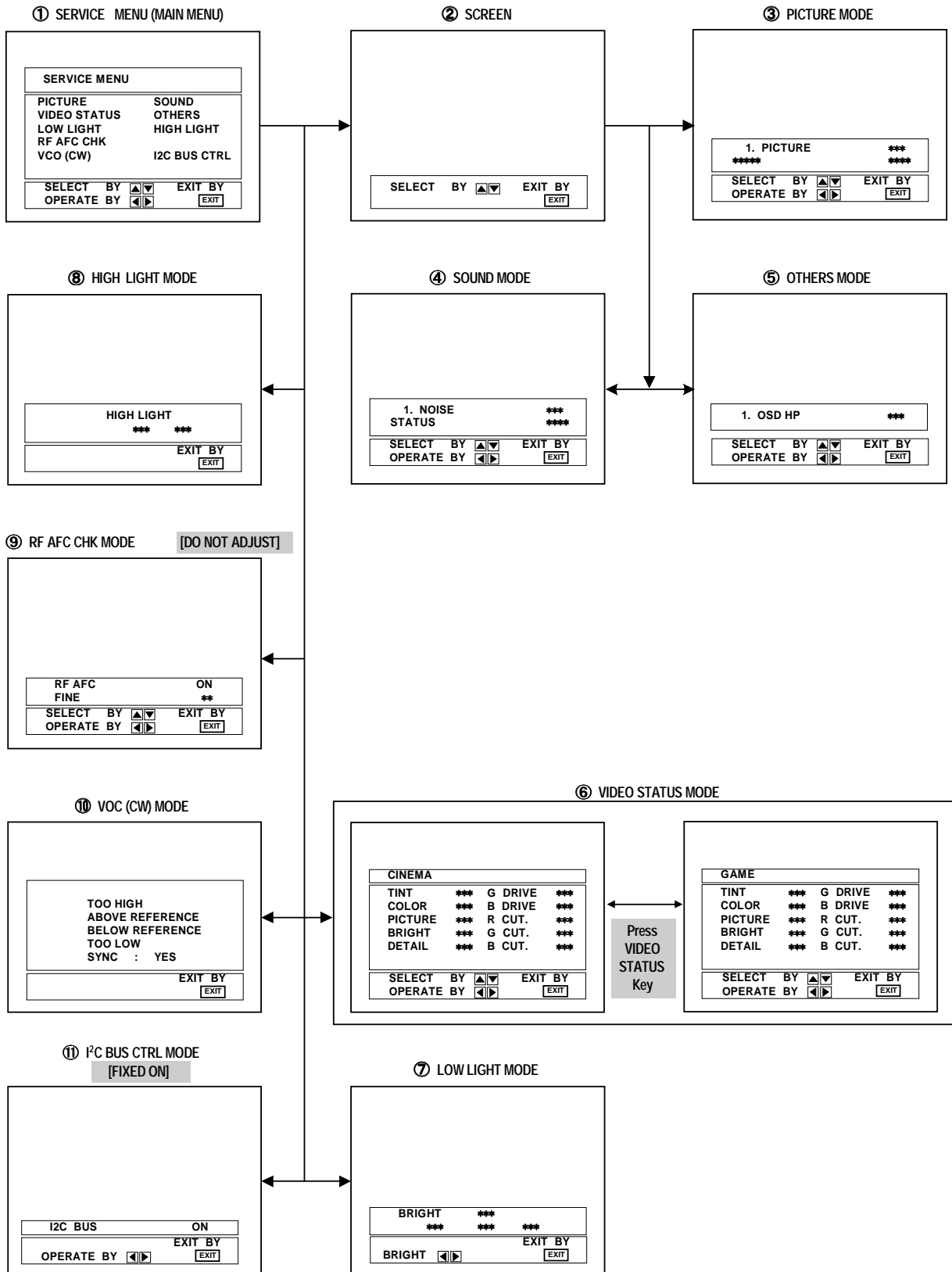

(4) Setting method

- 1) UP / DOWN key of the MENU
Select the SETTING ITEM.
- 2) LEFT / RIGHT key of the MENU
Setting (adjust) the SETTING VALUE of the SETTING ITEM.
When the key is released the SETTING VALUE will be stored (memorized).
- 3) EXIT key
Returns to the previous screen.

[NOTE] (PICTURE MODE ONLY)

When the INITIAL SETTING VALUE is turned to yellow, you can adjust the values but you cannot adjust the values when it is turned to red.
(Because the signal conditions, etc. are not met.)

(5) Releasing SERVICE MENU

- 1) After returning to the SERVICE MENU upon completion of the setting (adjustment) work, press the EXIT key again.

★ The settings for LOW LIGHT and HIGH LIGHT are described in the WHITE BALANCE page of ADJUSTMENT.

★ The setting for VCO (CW) are described in the IF VCO page of ADJUSTMENT.

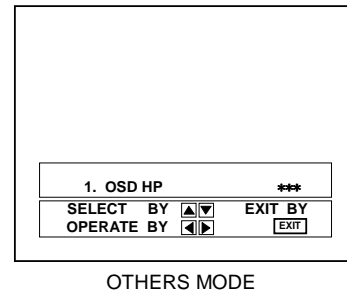
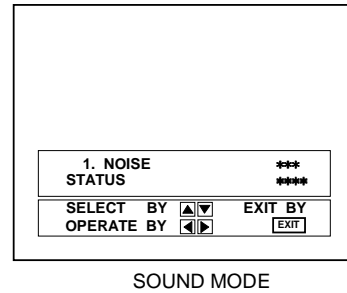
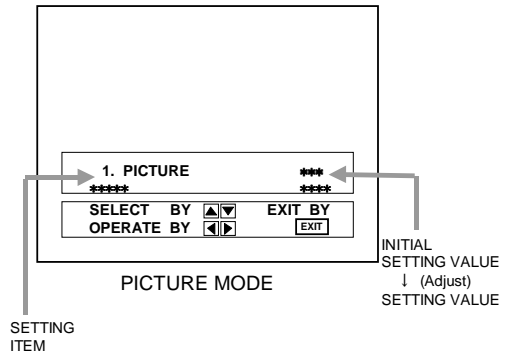

(The letter of the selected items are displayed in yellow.)

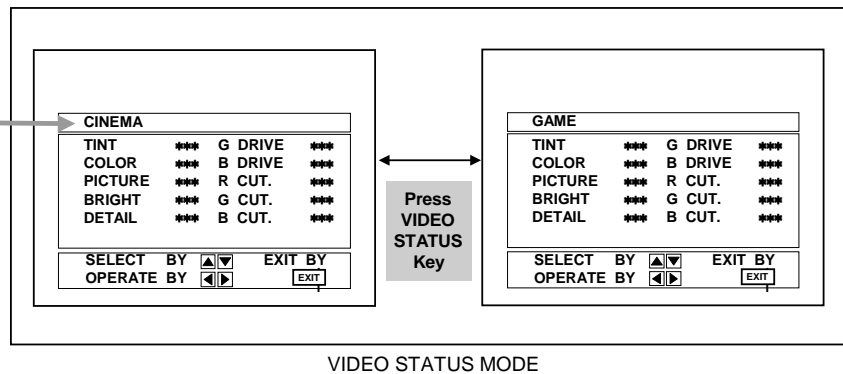

INITIAL SETTING VALUE OF SERVICE MENU

1. Adjustment of the SERVICE MENU is made on the basis of the initial setting values; however, the new setting values which set the screen in its optimum condition may differ from the initial setting.
2. Do not change the initial Setting Values of the Setting (Adjustment) items not listed in "ADJUSTMENT".

● PICTURE MODE

- ◇ The four setting items in the video mode No.8 EXT PIC., No.9 EXT BRI., No.10 EXT COL. and No.11 EXT TINT are linked to the items in the TV MODE No.1 PICTURE, No.2 BRIGHT, No.5 COL. NTSC and No.6 TINT, respectively. When the setting items in the TV mode are adjusted, the values in the setting items in the video mode are revised automatically to the same values in the TV mode.(The initial setting values given in () are off-set values.)
- ◇ When the four items (No.8, 9, 10 and 11) are adjusted in the video mode, the setting values in each item are revised independently.

No.	Setting item	Variable range	Initial setting value	No.	Setting item	Variable range	Initial setting value
1.	PICTURE	0~127	65	31.	C-TRAP	0 / 1	0
2.	BRIGHT	0~127	64	32.	C-TR. FO	0~3	2
3.	COL. PALM	0~127	70	33.	C-TRAP Q	0~3	0
4.	COL. PALN	0~127	70	34.	FIX B/W	0 / 1	0
5.	COL. NTSC	0~127	80	35.	APA P. FO	0~3	1
6.	TINT	0~127	65	36.	DC TRAN.	0~7	7
7.	TV DTL	0~63	38	37.	B. ST. SW	0~7	0
8.	EXT PIC.	±25	(0)	38.	B. ST. PO.	0 / 1	0
9.	EXT BRI.	±25	(+5)	39.	ABL GAIN	0~7	4
10.	EXT COL.	±25	(0)	40.	ABL PO	0~7	0
11.	EXT TINT	±25	+1	41.	HALF T.	0~2	1
12.	EXT DTL	0~63	35	42.	DRV G SW	0 / 1	0
13.	P/N KILL	0 / 1	1	43.	NT. COMB	0 / 1	1
14.	Y S CONT	0~31	31	44.	COIN DET	0~3	3
15.	TV Y-DL	0~7	1	45.	NOISE L	0~3	3
16.	EXT Y-DL	0~7	2	46.	VCD MODE	0 / 1	0
17.	WPL SW	0 / 1	0	47.	V AGC SP	0 / 1	0
18.	Y GAMMA	0 / 1	0	48.	H POS. 50	0~31	7
19.	P/N G P	0 / 1	0	49.	H BLK. 50	0~7	0
20.	COL. L SW	0 / 1	1	50.	V POS. 50	0~7	0
21.	COL. LMT.	0~3	1	51.	V SIZE50	0~127	87
22.	PN C. ATT	0~3	1	52.	V S CR50	0~127	28
23.	OFST. SW	0 / 1	0	53.	V LIN. 50	0~31	4
24.	OFSET. B-Y	0~15	8	54.	H POS. 60	0~31	12
25.	OFSET. R-Y	0~15	8	55.	H BLK. 60	0~7	0
26.	C-TOF SW	0 / 1	1	56.	V POS. 60	0~7	0
27.	TV T FO	0~3	1	57.	V SIZE60	0~127	88
28.	TV T Q	0~3	0	58.	V S CR60	0~127	48
29.	EXT T FO	0~3	0	59.	V LIN. 60	0~31	4
30.	EXT T Q	0~3	0	60.	RF AGC	0~255	160

● SOUND MODE

No.	Setting item	Variable range	Initial setting value
1.	NOISE	0 / 1	1
2.	IN LEVEL	0~63	20
3.	FH MON.	0 / 1	0
4.	ST VCO	0~63	25
5.	PILOT	0 / 1	0
6.	FILTER	0~63	30
7.	LOW SEP.	0~63	22
8.	HI SEP.	0~63	23
9.	5FH MON.	0 / 1	0
10.	SAP VCO	0~63	26
11.	IN GAIN	0 / 1	0
12.	FIL. OFF	±10	0

● VIDEO STATUS MODE

No.	Setting (Adjustment) item	Variable range	Initial setting value	
			CINEMA	GAME
1.	TINT	±20	0	0
2.	COLOR	±20	-3	-3
3.	PICTURE	±20	-10	-10
4.	BRIGHT	±20	0	0
5.	DETAIL	±15	0	-5
6.	G DRIVE	-99~+50	-22	0
7.	B DRIVE	-99~+50	-54	0
8.	R CUT.	±10	0	0
9.	G CUT.	±10	0	0
10.	B CUT	±10	0	0

● OTHERS MODE

No.	Setting (Adjustment) item	Variable range	Initial setting value
1.	OSD HP	0~31	23
2.	OSD VP	0~15	12
3.	H CK SW	0 / 1	0

● LOW LIGHT MODE

Setting (Adjustment) item	Variable range	Initial setting value
R CUTOFF	0~255	20
G CUTOFF	0~255	20
B CUTOFF	0~255	20

● HIGH LIGHT MODE

Setting (Adjustment) item	Variable range	Initial setting value
G DRIVE	0~255	128
B DRIVE	0~255	128

● RF AFC CHECK MODE

Setting (Adjustment) item	Variable range	Initial setting value
RF AFC	ON / OFF	ON (DO NOT ADJUST)
FINE	-77~+77	± * *

● I²C BUS CTRL MODE

Setting (Adjustment) item	Variable range	Initial setting value
I ² C BUS	ON / OFF	[Fixed ON]

■ ADJUSTMENTS

B1 POWER SUPPLY

Item	Measuring instrument	Test point	Adjustment item	Description
Check of B1 POWER SUPPLY	DC Voltmeter	B1 (B1 Connector [1] pin) (TP-91) TP-E(⏏) (B1 Connector [3] pin)		<ol style="list-style-type: none"> 1. Receive a black and white signal (color off). (NTSC) 2. Connect the DC voltmeter to B1 connector [1] pin (TP-91) and TP-E(⏏) (B1 connector [3] pin). 3. Confirm that the voltage is $DC134.5V \pm 2V$.

IF VCO ADJUSTMENT

Item	Measuring instrument	Test point	Adjustment item	Description
IF VCO adjustment	Signal generator		CW TRANSF. (T111) [VCO (CW)] mode	<ul style="list-style-type: none"> ● Under normal conditions, no adjustment is required. <ol style="list-style-type: none"> 1. Receive a broadcast. (use channels without offset frequency). 2. Select the VCO(CW) mode from the SERVICE MENU. 3. Confirm the color change (yellow) from "TOO HIGH" to "TOO LOW" by CW TRANSF. and "SYNC : YES" being shown on the screen. Then, adjust CW TRANSF. until "BELOW REFERENCE" mark turns yellow and confirm again " SYNC : YES" being shown on the screen.

RF AGC ADJUSTMENT

RF AGC adjustment			No.60 RF AGC	<ol style="list-style-type: none"> 1. Receive a broadcast. 2. Select "No.60 RF AGC" of the PICTURE mode in SERVICE MENU. 3. Press the MUTE key and turn off color. 4. With the MENU LEFT key, get noise in the screen picture. (0 side of setting value) 5. Press the MENU RIGHT key and stop when noise disappears from the screen. 6. Change to other channels and make sure that there is no irregularity. 7. Press the MUTE key and get color out.
-------------------	--	--	--------------	---

FOCUS ADJUSTMENT

FOCUS adjustment	Signal generator		FOCUS VR [In HVT]	<ol style="list-style-type: none"> 1. Receive a crosshatch signal. 2. While looking at the screen, adjust FOCUS VR so that the vertical and horizontal lines will be clear and in fine detail. 3. Make sure that the picture is in focus even when the screen gets darkened.
------------------	------------------	--	-------------------	---

DEFLECTION ADJUSTMENT

The setting (adjustment) using the REMOTE CONTROL UNIT is made on the basis of the initial setting values.
The setting values which adjust the screen to the optimum condition can be different from the initial setting values.

Item	Measuring instrument	Test point	Adjustment item	Description
V. HEIGHT, V. POSITION, V. LIN. V. S CR adjustment	Signal generator		No.56 V POS. 60 No.57 V SIZE 60 No.58 V S CR60 No.59 V. LIN. 60	[60Hz] 1. Receive a crosshatch signal.(NTSC or PAL-M) 2. Confirm that the value of PICTURE MODE "No.56 V POS. 60" is 0. 3. Confirm the initial setting value of the "No.57 V SIZE 60" , No.58 V S CR60" and "No.59 V LIN. 60" . 4. Adjust the vertical screen size to 92% with the PICTURE MODE "No.57 V SIZE60" . 5. Adjust the PICTURE MODE "No.59 L LIN. 60" and "No.58 V S CR60" to get the best vertical linearity. NOTE : The PICTURE MODE "No.56 V POS. 60" is fixed on value 0.
			No.50 V POS.50 No.51 V SISE 50 No.52 V S CR50 No.53 V LIN.50	[50Hz] 1. Receive a crosshatch signal. (PAL-N) 2. Confirm the initial setting value of the "No.50 V POS.50", "No.51 V SIZE 50" , "No.52 V S CR 50" and "No.53 V LIN.50". 3. Adjust the vertical screen size to 92% with the PICTURE MODE "No.51 V SIZE50". 4. Adjust the PICTURE MODE "No.53 V LIN.50" and "No.52 V S CR50" to get the best vertical linearity. 5. Adjust the PICTURE MODE "No.50 V POS.50" so that the vertical center line comes close to the CRT vertical center as much as possible. ● Readjust V SIZE, V LIN., V S CR if necessary.
H. POSITION adjustment	Signal generator		No.54 H POS.60	[60Hz] 1. Receive a crosshatch signal. (NTSC or PAL-M) 2. Select the "No.54 H POS. 60" of the PICTURE mode in SERVICE MENU. 3. Confirm the initial setting value of the "No.54 H POS. 60". 4. Adjust the "No.54 H POS. 60" until the screen will be horizontally centered.
			No.48 H POS.50	[50Hz] 1. Receive a crosshatch signal. (PAL-N) 2. Select the "No.48 H POS. 50" of the PICTURE mode in SERVICE MENU. 3. Confirm the initial setting value of the "No.48 H POS. 50". 4. Adjust the "No.48 H POS. 50" until the screen will be horizontally centered.

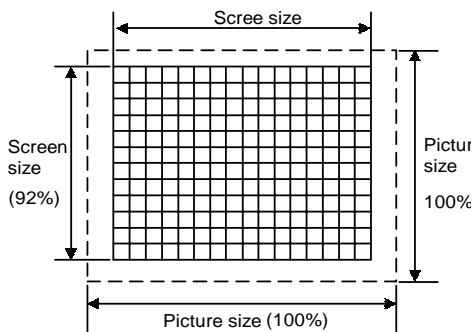

VIDEO / CHROMA ADJUSTMENT

The setting (adjustment) using the REMOTE CONTROL UNIT is made on the basis of the initial setting values.
 The setting values which adjust the screen to the optimum condition can be different from the initial setting values.
 Do not change the initial setting values of the setting items not listed in "ADJUSTMENT".

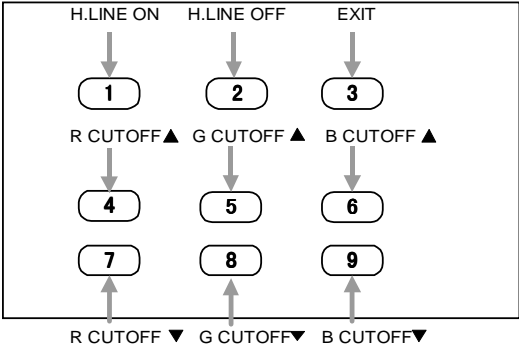
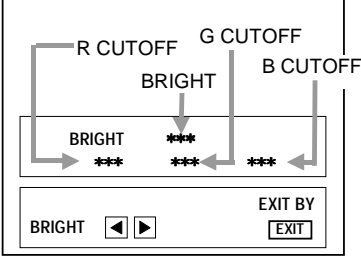
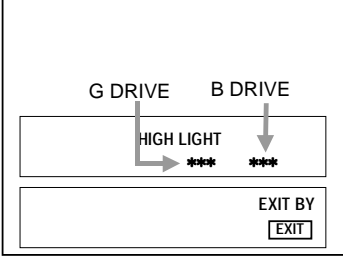
Item	Measuring instrument	Test point	Adjustment item	Description
<p>WHITE BALANCE (Low Light) adjustment</p>	<p>Signal generator Remote control unit</p>		<p>BRIGHT R CUTOFF G CUTOFF B CUTOFF SCREEN VR</p>	<ol style="list-style-type: none"> 1. Receive a black and white signal (color off). 2. Select the LOW LIGHT mode from the SERVICE MENU. 3. Confirm the Initial setting value of "BRIGHT", "R CUTOFF", "G CUTOFF" and "B CUTOFF". 4. Display a single horizontal line by pressing the ① key of the remote control unit. 5. Turn the screen VR all the way to the left. 6. Turn the screen VR gradually to the right from the left until either one of the red, blue or green colors appears faintly. 7. Adjust the two colors which did not appear until the single horizontal line that is displayed becomes white using the ④ to ⑨ keys of the remote control unit. 8. Turn the screen VR until the single horizontal line is displayed faintly. 9. Press the ② key to return to the regular screen.
<p>REMOTE CONTROL UNIT</p> 				
<p>[LOW LIGHT] MODE</p> 				
<p>WHITE BALANCE (High Light) adjustment</p>	<p>Signal generator Remote control unit</p>		<p>G DRIVE B DRIVE</p>	<ol style="list-style-type: none"> 1. Receive a black and white signal (color off). 2. Select the HIGH LIGHT mode in the SERVICE MENU. 3. Confirm the initial setting value of "G DRIVE" and "B DRIVE". 4. Adjust the screen color to white with the ⑤, ⑥, ⑧ and ⑨ keys of the remote control unit.
<p>Remote Control Unit</p> <ul style="list-style-type: none"> ①key : H.LINE ON ②key : H.LINE OFF ③key : EXIT ⑤key : G DRIVE ▲ ⑥key : B DRIVE ▲ ⑧key : G DRIVE ▼ ⑨key : B DRIVE ▼ 				
<p>[HIGH LIGHT] MODE</p> 				

Item	Measuring instrument	Test point	Adjustment item	Description
SUB BRIGHT adjustment	Remote control unit		No.2 BRIGHT	<ol style="list-style-type: none"> 1. Receive a broadcast. 2. Select "No.2 BRIGHT" of the PICTURE mode in SERVICE MENU. 3. Confirm the initial setting value of the "No.2 BRIGHT" . 4. If the brightness is not the best with the initial setting value, make fine adjustment of the "No.2 BRIGHT" until you get the optimum brightness.
SUB CONTRAST adjustment	Remote control unit		No.1 PICTURE	<ol style="list-style-type: none"> 1. Receive a broadcast. 2. Select "No.1 PICTURE" of the PICTURE mode in SERVICE MENU. 3. Confirm the initial setting value of the "No.1 PICTURE". 4. If the contrast is not the best with the initial setting value, make fine adjustment of the "No.1 PICTURE" until you get the optimum contrast.
SUB COLOR adjustment	Remote control unit		No.3 COL. PALM No.4 COL. PALN No.5 COL. NTSC	<p>[PAL-M]</p> <ol style="list-style-type: none"> 1. Receive a PAL-M color bar signal. 2. Select "No.3 COL. PALM" of the PICTURE mode in SERVICE MENU. 3. Confirm the initial setting value of the "No.3 COL. PALM". 4. If the color is not the best with the initial setting value, make fine adjustment until you get the best color. <p>[PAL-N]</p> <ol style="list-style-type: none"> 1. Receive a PAL-N color bar signal. 2. Select "No.4 COL. PALN" of the PICTURE mode in SERVICE MENU. 3. Confirm the initial setting value of the "No.4 COL. PALN". 4. If the color is not the best with the initial setting value, make fine adjustment until you get the best color. <p>[NTSC]</p> <ol style="list-style-type: none"> 1. Receive a NTSC color bar signal. 2. Select "No.5 COL. NTSC" of the PICTURE mode in SERVICE MENU. 3. Confirm the initial setting value of the "No.5 COL. NTSC". 4. If the color is not the best with the initial setting value, make fine adjustment until you get the best color.
SUB TINT adjustment	Remote control unit		No. 6 TINT	<ol style="list-style-type: none"> 1. Receive a NTSC color bar signal. 2. Select "No. 6 TINT" of the PICTURE mode in SERVICE MENU. 3. Confirm the initial setting value of the "No. 6 TINT". 4. If the tint is not the best with the initial setting value, make fine adjustment until you get the best tint.

MTS ADJUSTMENT

Item	Measuring instrument	Test point	Adjustment part	Description
INPUT LEVEL adjustment			No.2 IN LEVEL	<ol style="list-style-type: none"> 1. Select the "No.2 IN LEVEL" of the SOUND mode in SERVICE MENU. 2. Verify that the "No.2 IN LEVEL" is set at its initial setting value.
STEREO VCO adjustment	Signal generator Frequency counter	MPX Connector 2 pin TVR [MAIN PWB]	No.3 FH MON No.4 ST VCO	<ol style="list-style-type: none"> 1. Receive a NTSC RF signal (non modulated sound signal) from the antenna terminal. 2. Select the "No.3 FH MON" of SOUND mode in SERVICE MENU, change the setting value from 0 to 1. 3. Connect the frequency connector to pin 2 of MPX connector. 4. Select the "No.4 ST VCO". 5. Confirm the initial setting value of the "No.4 ST VCO". 6. Adjust the "No.4 ST VCO" so that the frequency counter will display $15.73\text{kHz} \pm 0.1\text{kHz}$. 7. Select the "No.3 FH MON" of the SOUND mode, and reset the setting value from 1 to 0.
SAP VCO adjustment	Signal generator Frequency counter	MPX Connector 4 pin SDA 3 pin GND 2 pin TVR [MAIN PWB]	No.9 5FH MON. No.10 SAP VCO.	<ol style="list-style-type: none"> 1. Receive a NTSC RF signal (non modulated sound signal) from the antenna terminal. 2. Connect between pin 4 of MPX connector and GND (pin 3 of MPX connector) through $1\text{M}\Omega$ resistor. 3. Select the "No.9 5FH MON." of the SOUND mode in SERVICE MENU, and reset the setting value from 0 to 1. 4. Connect the frequency connector to pin 2 (R.OUT) of MPX connector. 5. Select the "No.10 SAP VCO". 6. Confirm the initial setting value of "No.10 SAP VCO". 7. Adjust the "No.10 SAP VCO" so that the frequency connector will display $78.67\text{kHz} \pm 0.5\text{kHz}$. 8. Select the "No.9 5FH MON." of the SOUND mode, and reset the setting value from 1 to 0.
FILTER check			No.6 FILTER	<ol style="list-style-type: none"> 1. Select the "No.6 FILTER" of the SOUND mode in SERVICE MENU. 2. Verify that the "No.6 FILTER" is set at its initial setting value.

Item	Measuring instrument	Test point	Adjustment part	Description
<p>SEPARATION adjustment</p>	<p>TV audio multiplex signal generator Oscilloscope</p>	<p>[MPX] Connector 1 pin TVL 2 pin TVR [MAIN PWB]</p>	<p>No.7 LOW SEP. No.8 HI SEP.</p>	<ol style="list-style-type: none"> 1. Input a stereo L signal (300Hz) from the TV Audio multiplex signal generator to the antenna terminal. (NTSC) 2. Connect an oscilloscope to pin 2 (R.OUT) of [MPX] connector, and display one cycle portion of the 300Hz signal. 3. Select the "No.7 LOW SEP." of the SOUND mode in SERVICE MENU. 4. Confirm the initial setting value of the "No.7 LOW SEP." 5. Adjust the "No.7 LOW SEP." so that the stroke element of the 300Hz signal will become minimum. 6. Change the connection of the oscilloscope to pin 1 (L.OUT) of [MPX] connector, and enlarge the voltage axis. 7. Change the signal to 3kHz, and similarly adjust the "No.8 HI SEP."

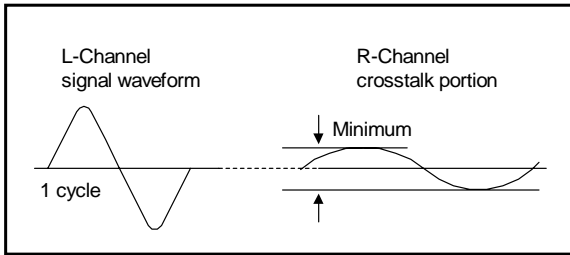

PURITY, CONVERGENCE

PURITY ADJUSTMENT

1. Demagnetize CRT with the demagnetizer.
2. Loosen the retainer screw of the deflection yoke.
3. Remove the wedges.
4. Input a green raster signal from the signal generator, and turn the screen to green raster.
5. Move the deflection yoke backward.
6. Bring the long lug of the purity magnets on the short lug and position them horizontally. (Fig.2)
7. Adjust the gap between two lugs so that the GREEN RASTER will come into the center of the screen. (Fig.3)
8. Move the deflection yoke forward, and fix the position of the deflection yoke so that the whole screen will become green.
9. Insert the wedge to the top side of the deflection yoke so that it will not move.
10. Input a crosshatch signal.
11. Verify that the screen is horizontal.
12. Input red and blue raster signals, and make sure that purity is properly adjusted.

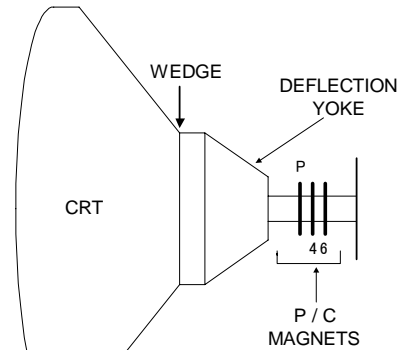

• P/C MAGNETS

P : PURITY MAGNET
 4 : 4 POLES (convergence magnets)
 6 : 6 POLES (convergence magnets)

Fig.1

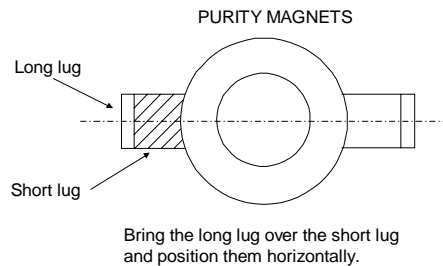

Fig.2

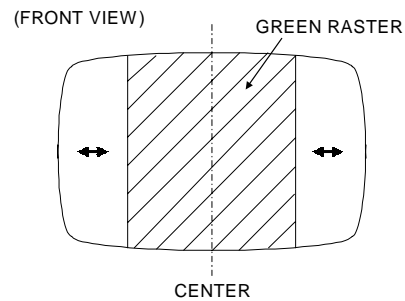

Fig.3

STATIC CONVERGENCE ADJUSTMENT

1. Input a crosshatch signal.
2. Using 4-pole convergence magnets, overlap the red and blue lines in the center of the screen (Fig.1) and turn them to magenta (red/blue).
3. Using 6-pole convergence magnets, overlap the magenta(red/blue) and green lines in the center of the screen and turn them to white.
4. Repeat 2 and 3 above, and make best convergence.

DYNAMIC CONVERGENCE ADJUSTMENT

1. Move the deflection yoke up and down and overlap the lines in the periphery. (Fig. 2)
 2. Move the deflection yoke left to right and overlap the lines in the periphery. (Fig. 3)
 3. Repeat 1 and 2 above, and make best convergence.
- After adjustment, fix the wedge at the original position.
Fasten the retainer screw of the deflection yoke.
Fix the 6 magnets with glue.

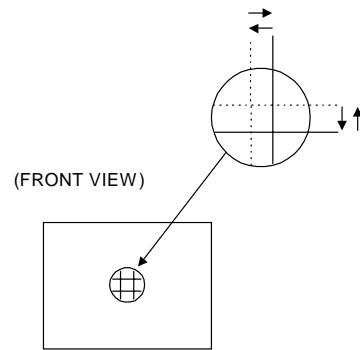

Fig.1

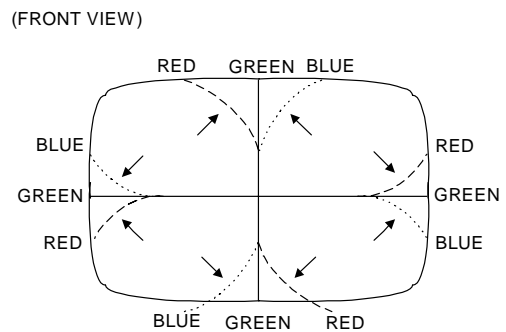

Fig.2

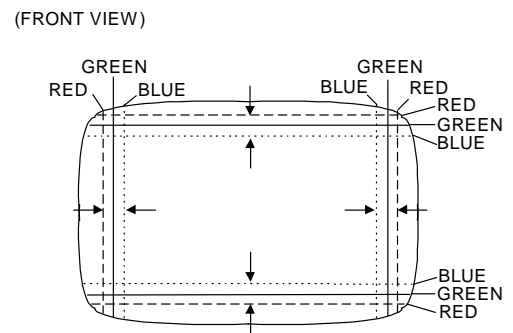

Fig.3

HOW TO CHECK THE HIGH VOLTAGE HOLD DOWN CIRCUIT

1. HIGH VOLTAGE HOLD DOWN CIRCUIT

After repairing the high voltage hold down circuit shown in Fig. 1.
This circuit shall be checked to operate correctly.

2. CHECKING OF THE HIGH VOLTAGE HOLD DOWN CIRCUIT

- (1) Turn the POWER SW ON.
- (2) As shown in Fig.2, set the resistor (between X connector 1 & 3).
- (3) Make sure that the screen picture disappears.
- (4) Temporarily unplug the power cord.
- (5) Remove the resistor (between X connector 1 & 3).
- (6) Again plug the power cord, make sure that the normal picture is displayed on the screen.

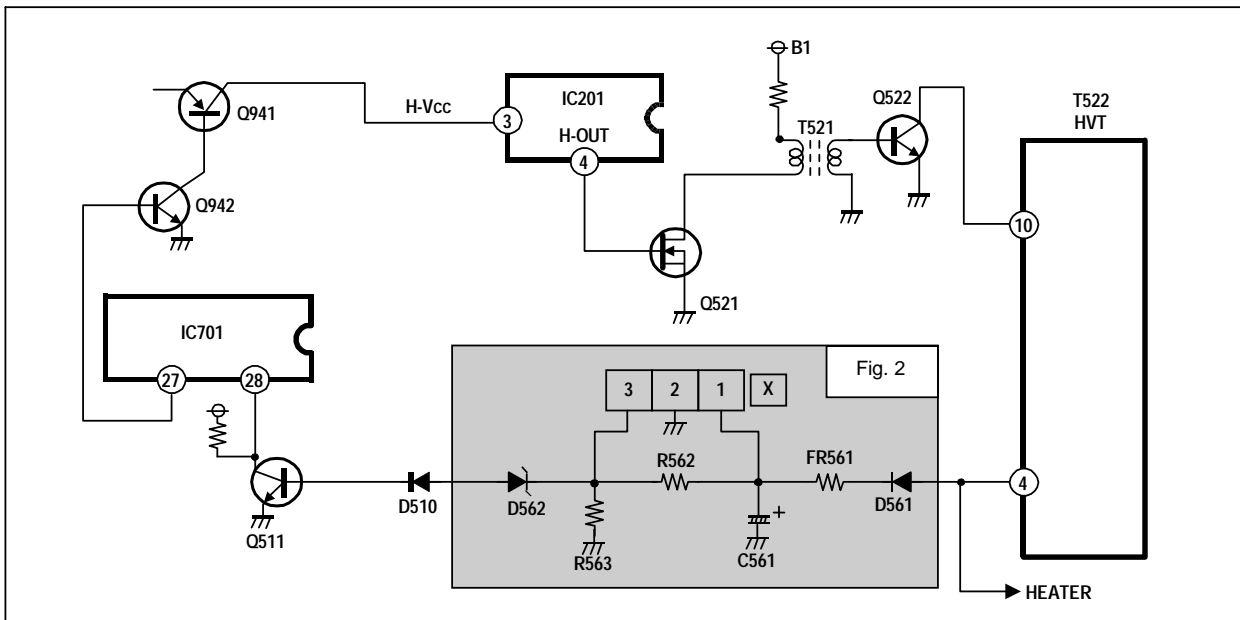

Fig. 1

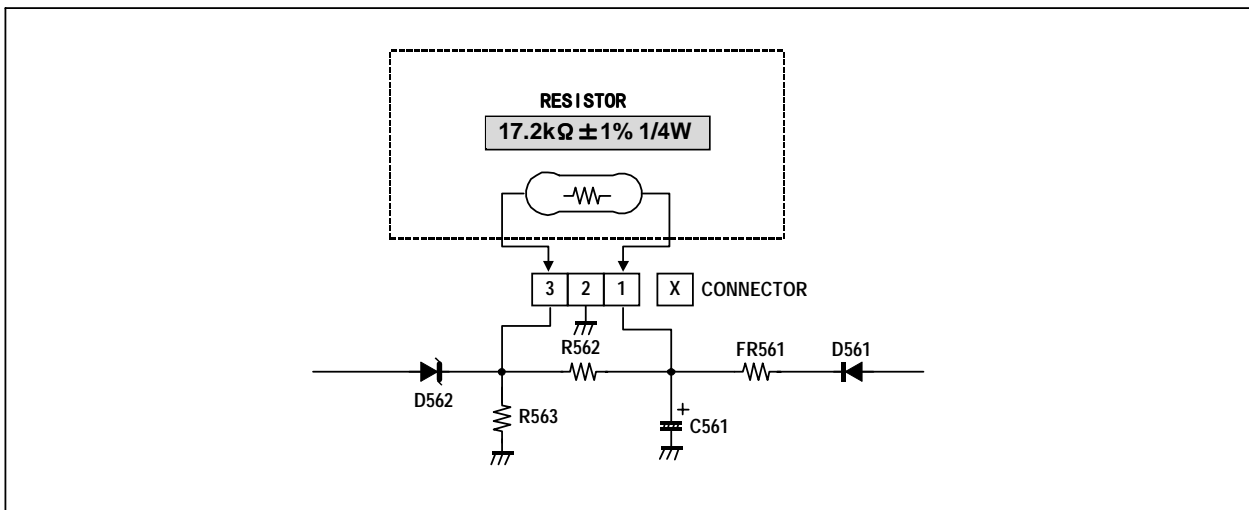

Fig. 2

SELF CHECK FUNCTIONS

1. Outline

This model includes protector functions for Over-current, X-ray and CRT NECK which cutoff the sub-power in the event of a malfunction and inform of the malfunction by flashing POWER/ON TIMER LED.

The malfunction is detected according to the state of the control line input connected to the main CPU.

2. Self check items

Check item	Detected contents	Detection method	Abnormality state
Over-current protector	Operation of over-current protection circuit	The main CPU detects at 1second intervals. If NG is detected for more than 1ms, a malfunction is interpreted	During an abnormality the sub-power is cutoff. The remote controller power key operation is not recognized and sub-power off is maintained until the power cord is unplugged and reinserted.
X-ray protector	Operation of X-ray protection circuit	The main CPU detects at 1second intervals. If NG is detected for more than 1ms, a malfunction is interpreted	During an abnormality the sub-power is cutoff. The remote controller power key operation is not recognized and sub-power off is maintained until the power cord is unplugged and reinserted.
CRT NECK protector	When the vertical circuit S-correction capacitor C413 is shorted, detect the potential drop of the C413, and prevent the burn damage to the CRT NECK.	The main CPU detects at 1second intervals. If NG is detected for more than 1ms, a malfunction is interpreted	During an abnormality the sub-power is cutoff. The remote controller power key operation is not recognized and sub-power off is maintained until the power cord is unplugged and reinserted.

3. Self check indicating function

The self check function begins detection about 5 seconds after power is supplied.

In the event a malfunction is detected, the sub-power is cutoff immediately.

At this time, the POWER/ON TIMER LED flashes to inform of the malfunction.

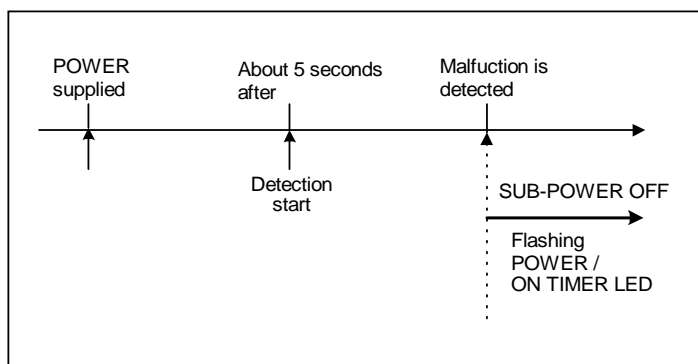

Item	LED flashing intervals	Priority of detection
OCP/X-ray	Red and green LED flash alternately at 0.5 second intervals	1
NECK	Red and green LED flash alternately at 1.0 second intervals	2

REPLACEMENT OF CHIP COMPONENT

■ CAUTIONS

1. Avoid heating for more than 3 seconds.
2. Do not rub the electrodes and the resist parts of the pattern.
3. When removing a chip part, melt the solder adequately.
4. Do not reuse a chip part after removing it.

■ SOLDERING IRON

1. Use a high insulation soldering iron with a thin pointed end of it.
2. A 30w soldering iron is recommended for easily removing parts.

■ REPLACEMENT STEPS

1. How to remove Chip parts

◆ Resistors, capacitors, etc.

- (1) As shown in the figure, push the part with tweezers and alternately melt the solder at each end.

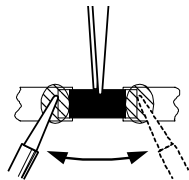

- (2) Shift with tweezers and remove the chip part.

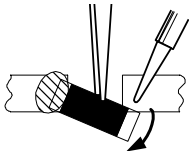

◆ Transistors, diodes, variable resistors, etc.

- (1) Apply extra solder to each lead.

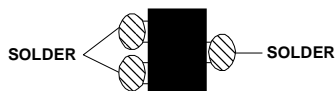

- (2) As shown in the figure, push the part with tweezers and alternately melt the solder at each lead. Shift and remove the chip part.

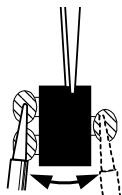

Note : After removing the part, remove remaining solder from the pattern.

2. How to install Chip parts

◆ Resistors, capacitors, etc.

- (1) Apply solder to the pattern as indicated in the figure.

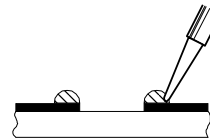

- (2) Grasp the chip part with tweezers and place it on the solder. Then heat and melt the solder at both ends of the chip part.

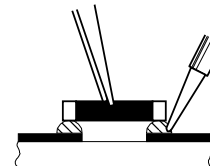

◆ Transistors, diodes, variable resistors, etc.

- (1) Apply solder to the pattern as indicated in the figure.
- (2) Grasp the chip part with tweezers and place it on the solder.
- (3) First solder lead **A** as indicated in the figure.

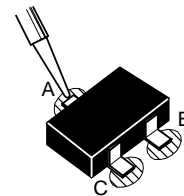

- (4) Then solder leads **B** and **C**.

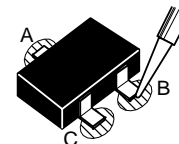

AV-T2122_{AR} STANDARD CIRCUIT DIAGRAM

NOTE ON USING CIRCUIT DIAGRAMS

1. SAFETY

The components identified by the Δ symbol and shading are critical for safety. For continued safety replace safety critical components only with manufactures recommended parts.

2. SPECIFIED VOLTAGE AND WAVEFORM VALUES

The voltage and waveform values have been measured under the following conditions.

- (1) Input signal : Color bar signal
- (2) Setting positions of each knob/button and variable resistor : Original setting position when shipped
- (3) Internal resistance of tester : DC 20k Ω /V
- (4) Oscilloscope sweeping time : H \Rightarrow 20 μ S/div
: V \Rightarrow 5mS/div
: Others \Rightarrow Sweeping time is specified
- (5) Voltage values : All DC voltage values
* Since the voltage values of signal circuit vary to some extent according to adjustments, use them as reference values.

3. INDICATION OF PARTS SYMBOL [EXAMPLE]

- In the PW board : R1209—R209

4. INDICATIONS ON THE CIRCUIT DIAGRAM

(1) Resistors

● Resistance value

- No unit : [Ω]
K : [K Ω]
M : [M Ω]

● Rated allowable power

- No indication : 1/10 [W]
Others : As specified

● Type

- No indication : Carbon resistor
OMR : Oxide metal film resistor
MFR : Metal film resistor
MPR : Metal plate resistor
UNFR : Uninflammable resistor
FR : Fusible resistor

* Composition resistor 1/2 [W] is specified as 1/2S or Comp.

(2) Capacitors

● Capacitance value

- 1 or higher : [pF]
less than 1 : [pF]

● Withstand voltage

- No indication : DC50[V]
Others : DC withstand voltage [V]
AC indicated : AC withstand voltage [V]

* Electrolytic Capacitors

47/50[Example]Capacitance value [μ F]/withstand voltage[V]

- Type
- | | |
|---------------|-------------------------------------|
| No indication | : Ceramic capacitor |
| MY | : Mylar capacitor |
| MM | : Metalized mylar capacitor |
| PP | : Polypropylene capacitor |
| MPP | : Metalized polypropylene capacitor |
| MIF | : Metalized film capacitor |
| TF | : Thin film capacitor |
| BP | : Bipolar electrolytic capacitor |
| TAN | : Tantalum capacitor |

(3) Coils

- No unit : [μ H]
Others : As specified

(4) Power Supply

- :B1  :B2(12V)



-  :9V  :5V

* Respective voltage values are indicated





(5) Test point

-  : Test point  : Only test point display

(6) Connecting method

-  : Connector  : Wrapping or soldering
 : Receptacle

(7) Ground symbol

-  : LIVE side ground
 : ISOLATED(NEUTRAL) side ground
 : EARTH ground
 : DIGITAL ground

5. NOTE FOR REPAIRING SERVICE

This model's power circuit is partly different in the GND. The difference of the GND is shown by the LIVE : (\perp) side GND and the ISOLATED(NEUTRAL) : (\perp) side GND. Therefore, care must be taken for the following points.

- (1) Do not touch the LIVE side GND or the LIVE side GND and the ISOLATED(NEUTRAL) side GND simultaneously. If the above caution is not respected, an electric shock may be caused. Therefore, make sure that the power cord is surely removed from the receptacle when, for example, the chassis is pulled out.
- (2) Do not short between the LIVE side GND and ISOLATED(NEUTRAL) side GND or never measure with a measuring apparatus (oscilloscope, etc.) the LIVE side GND and ISOLATED(NEUTRAL) side GND at the same time. If the above precaution is not respected, a fuse or any parts will be broken.

◇ Since the circuit diagram is a standard one, the circuit and circuit constants may be subject to change for improvement without any notice.

◇ NOTE

Due improvement in performance, some part numbers show in the circuit diagram may not agree with those indicated in the part list.

When ordering parts, please use the numbers that appear in the Parts List.

CONTENTS

SEMICONDUCTOR SHAPES..... 2-2

BLOCK DIAGRAM..... 2-3

CIRCUIT DIAGRAMS

MAIN PWB CIRCUIT DIAGRAM 2-5

MAIN PWB & CRT SOCKET PWB CIRCUIT DIAGRAM 2-7

PATTERN DIAGRAMS

MAIN PWB PATTERN 2-9

CRT PWB PATTERN (Within MAIN PWB) 2-11

SEMICONDUCTOR SHAPES

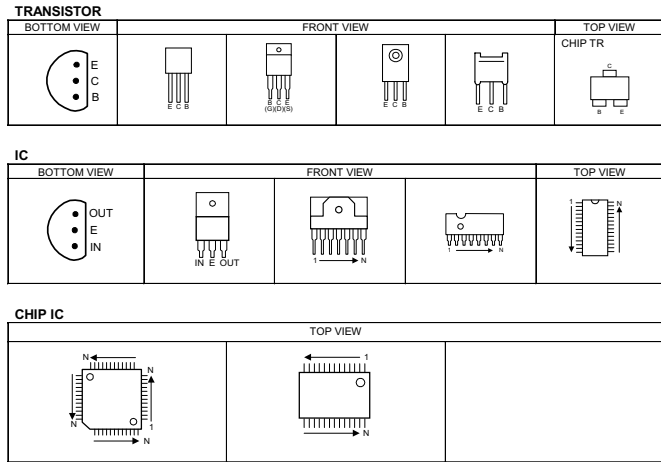

CRT SOCKET PWB PATTERN (Within MAIN PWB)

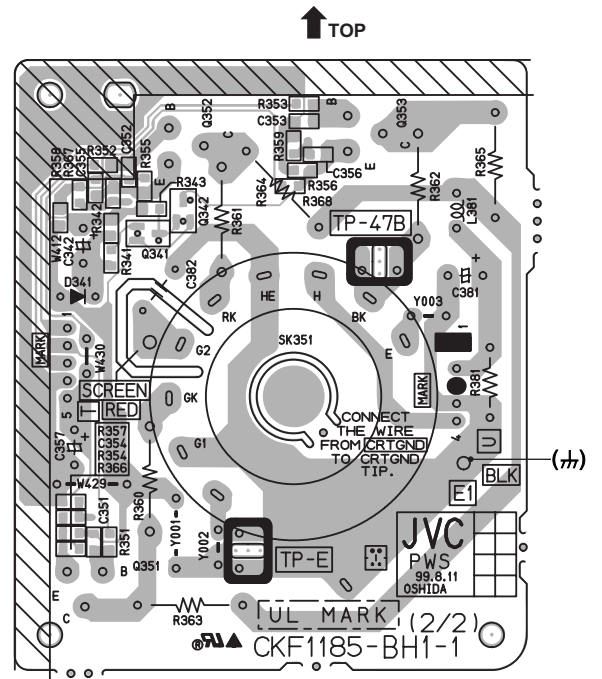

BLOCK DIAGRAM

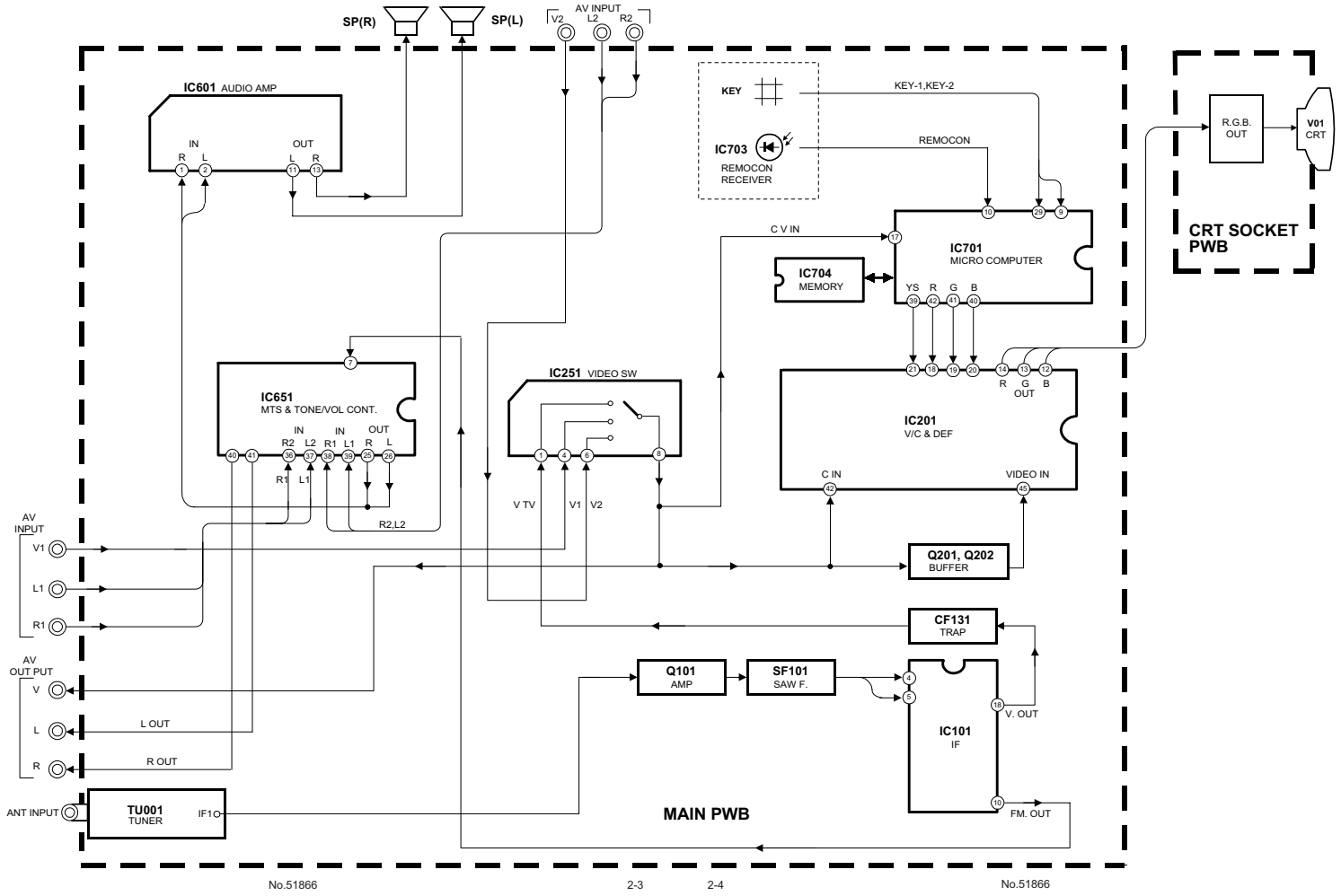

CIRCUIT DIAGRAMS
MAIN PWB CIRCUIT DIAGRAM

MAIN PWB (1/2)
SGA-1019A-R2

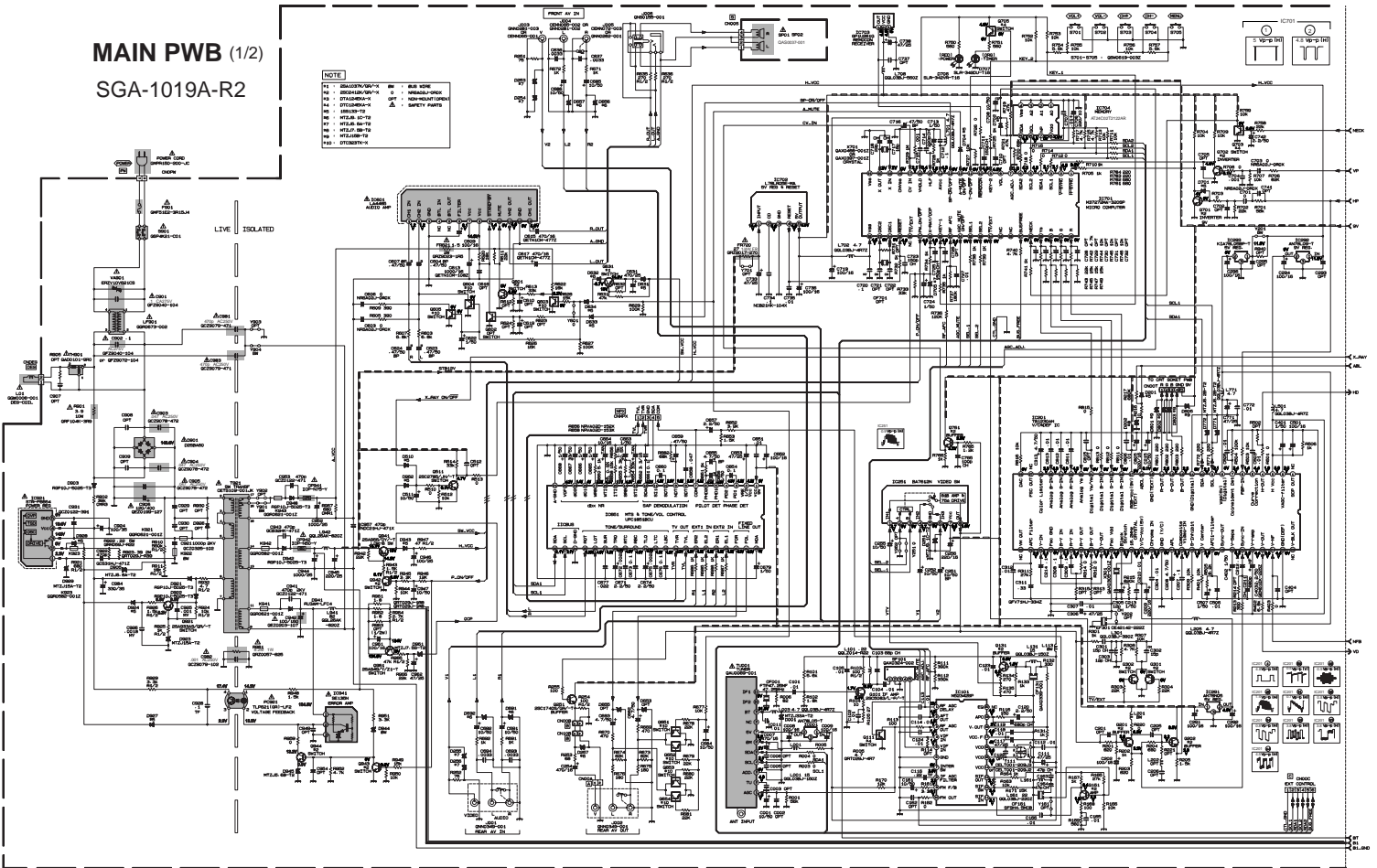

MAIN PWB & CRT SOCKET PWB CIRCUIT DIAGRAM

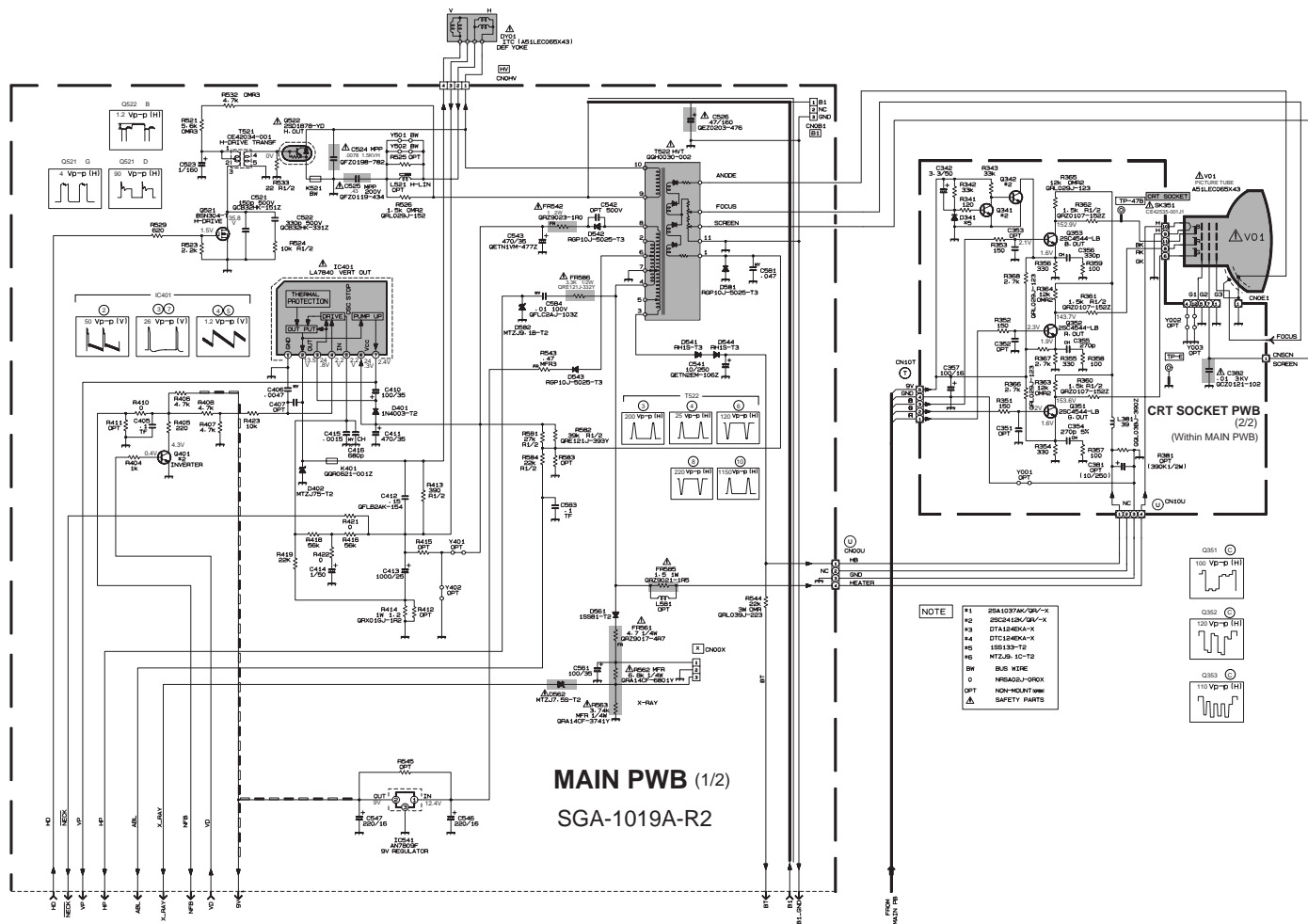

PARTS LIST

CAUTION

- The parts identified by the \triangle symbol are important for the safety. Whenever replacing these parts, be sure to use specified ones to secure the safety .
- The parts not indicated in this Parts List and those which are filled with lines — in the Parts No. columns will not be supplied.
- P. W. Board Ass'y will not be supplied, but those which are filled with the Parts No. in the Parts No. columns will be supplied.

ABBREVIATIONS OF RESISTORS, CAPACITORS AND TOLERANCES

RESISTORS		CAPACITORS	
C R	Carbon Resistor	C CAP.	Ceramic Capacitor
F R	Fusible Resistor	E CAP.	Electrolytic Capacitor
P R	Plate Resistor	M CAP.	Mylar Capacitor
V R	Variable Resistor	HV CAP.	High Voltage Capacitor
HV R	High Voltage Resistor	MF CAP.	Metalized Film Capacitor
MF R	Metal Film Resistor	MM CAP.	Metalized Mylar Capacitor
MG R	Metal Glazed Resistor	MP CAP.	Metalized Polystyrol Capacitor
MP R	Metal Plate Resistor	PP CAP.	Polypropylene Capacitor
OM R	Metal Oxide Film Resistor	PS CAP.	Polystyrol Capacitor
CMF R	Coating Metal Film Resistor	TF CAP.	Thin Film Capacitor
UNF R	Non-Flammable Resistor	MPP CAP.	Metalized Polypropylene Capacitor
CH V R	Chip Variable Resistor	TAN. CAP.	Tantalum Capacitor
CH MG R	Chip Metal Glazed Resistor	CH C CAP.	Chip Ceramic Capacitor
COMP. R	Composition Resistor	BP E CAP.	Bi-Polar Electrolytic Capacitor
LPTC R	Linear Positive Temperature Coefficient Resistor	CH AL E CAP.	Chip Aluminum Electrolytic Capacitor
		CH AL BP CAP.	Chip Aluminum Bi-Polar Capacitor
		CH TAN. E CAP.	Chip Tantalum Electrolytic Capacitor
		CH AL BP E CAP.	Chip Tantalum Bi-Polar Electrolytic Capacitor

TOLERANCES									
F	G	J	K	M	N	R	H	Z	P
±1%	±2%	±5%	±10%	±20%	±30%	+30% -10%	+50% -10%	+80% -20%	+100% -0%

CONTENTS

- EXPLODED VIEW PARTS LIST 30
- EXPLODED VIEW 31
- PRINTED WIRING BOARD PARTS LIST
 - MAIN PW BOARD ASS'Y (SGA-1019A-R2) (With CRT SOCKET PW BOARD) 32
- PACKING / PACKING PARTS LIST 36
- REMOTE CONTROL UNIT PARTS LIST 36

EXPLODED VIEW PARTS LIST

△ Ref.No.	Part No.	Part Name	Description
△ V01	A51LEC065X43	PICTURE TUBE(C)	Inc.DY, PC MAGNET, WEDGE
△ L01	QQW0006-001	DEG.COIL	
△ T1522	QQH0030-002	H.V.TRANSF.	
△ 1	LC10394-034A-HK	FRONT CABINET	
△ 2	LC20292-004A-H	CONTROL KNOB	
△ 3	LC30618-001A-H	L.E.D.LENS	
△ 4	CM48006-007-C	JVC MARK	
△ 5	LC30617-001C-H	E.E. WINDOW	
△ 6	LC30616-004A-H	POWER KNOB	
7	CM30861-084	SPRING	
8	A48457-4-5	SPRING	
9	CHGB0016-0B-GS	BRAIDED WIRE	
△ 10	CM36623-B01-H	CHASSIS RAIL	(×2)
△ 11	QAS0037-001	SPEAKER	(×2)SP01-02
△ 12	CM47005-A01-H	POWER CORD CLAMP	
△ 13	QMPR150-200-JC	POWER CORD	
△ 14	LC10448-003A-HK	REAR COVER	
△ 15	LC30462-007A-D	RATING LABEL	
16	QYSBSF3010Z	TAPPING SCREW	(×2)
17	QYSBSFG4016Z	TAPPING SCREW	(×6)
△ 18	LC30819-001A	TERMINAL SHEET	

EXPLODED VIEW

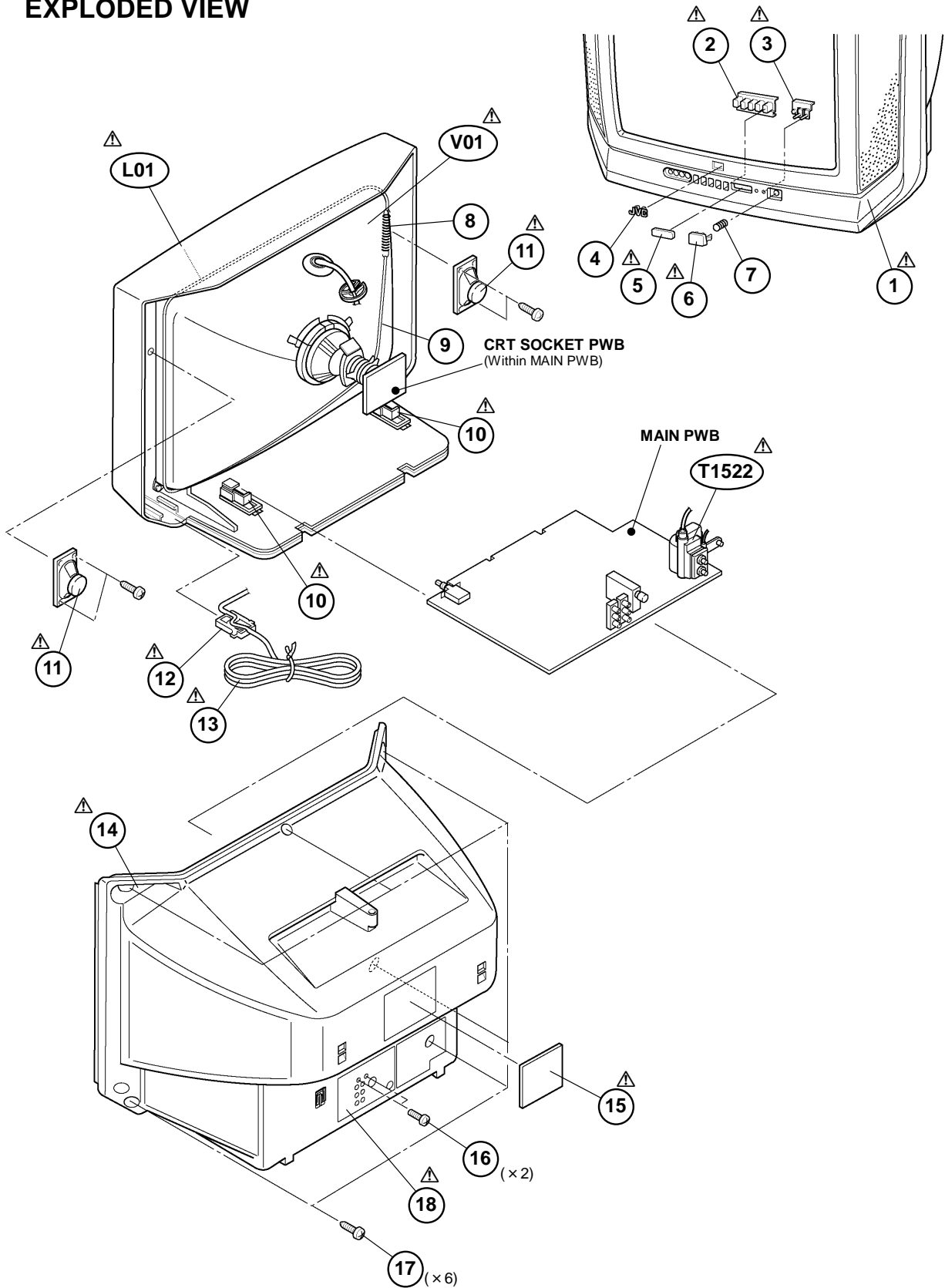

PRINTED WIRING BOARD PARTS LIST

MAIN P.W. BOARD ASS'Y (SGA-1019A-R2)

Symbol No.	Part No.	Part Name	Description
RESISTOR			
R1001	NRSA02J-563X	MG R	56kΩ 1/10W J
R1003-04	NRSA02J-0ROX	MG R	0.0Ω 1/10W J
R1005	QRT029J-4R7	MF R	4.7Ω 2W J
R1006	NRSA02J-820X	MG R	82Ω 1/10W J
R1101	NRSA02J-562X	MG R	5.6kΩ 1/10W J
R1102	NRSA02J-182X	MG R	1.8kΩ 1/10W J
R1103	QRE121J-101Y	C R	100Ω 1/2W J
R1104	NRSA02J-100X	MG R	10Ω 1/10W J
R1105	NRSA02J-270X	MG R	27Ω 1/10W J
R1111	NRSA02J-394X	MG R	390kΩ 1/10W J
R1112	NRSA02J-334X	MG R	330kΩ 1/10W J
R1113	NRSA02J-101X	MG R	100Ω 1/10W J
R1116	NRSA02J-151X	MG R	150Ω 1/10W J
R1131	NRSA02J-102X	MG R	1kΩ 1/10W J
R1132	NRSA02J-331X	MG R	330Ω 1/10W J
R1133	NRSA02J-102X	MG R	1kΩ 1/10W J
R1134	NRSA02J-271X	MG R	270Ω 1/10W J
R1135	NRSA02J-471X	MG R	470Ω 1/10W J
R1161	NRSA02J-332X	MG R	3.3kΩ 1/10W J
R1162	NRSA02J-0ROX	MG R	0.0Ω 1/10W J
R1163	NRSA02J-103X	MG R	10kΩ 1/10W J
R1164	NRSA02J-102X	MG R	1kΩ 1/10W J
R1165	NRSA02J-273X	MG R	27kΩ 1/10W J
R1166	NRSA02J-103X	MG R	10kΩ 1/10W J
R1167	NRSA02J-102X	MG R	1kΩ 1/10W J
R1168	NRSA02J-101X	MG R	100Ω 1/10W J
R1169	NRSA02J-561X	MG R	560Ω 1/10W J
R1170	NRSA02J-123X	MG R	12kΩ 1/10W J
R1171	NRSA02J-153X	MG R	15kΩ 1/10W J
R1201	NRSA02J-821X	MG R	820Ω 1/10W J
R1202	NRSA02J-102X	MG R	1kΩ 1/10W J
R1203	NRSA02J-821X	MG R	820Ω 1/10W J
R1204	NRSA02J-681X	MG R	680Ω 1/10W J
R1205	NRSA02J-152X	MG R	1.5kΩ 1/10W J
R1213	NRSA02J-391X	MG R	390Ω 1/10W J
R1215	NRSA02J-824X	MG R	820kΩ 1/10W J
R1216	NRSA02J-0ROX	MG R	0.0Ω 1/10W J
R1217	NRSA02J-684X	MG R	680kΩ 1/10W J
R1220	NRSA02J-0ROX	MG R	0.0Ω 1/10W J
R1251-52	NRSA02J-750X	MG R	75Ω 1/10W J
R1253	NRSA02J-680X	MG R	68Ω 1/10W J
R1254	QRE121J-101Y	C R	100Ω 1/2W J
R1255	NRSA02J-101X	MG R	100Ω 1/10W J
R1301	NRSA02J-102X	MG R	1kΩ 1/10W J
R1303	NRSA02J-223X	MG R	22kΩ 1/10W J
R1304	NRSA02J-223X	MG R	22kΩ 1/10W J
R1307	NRSA02J-103X	MG R	10kΩ 1/10W J
R1308	NRSA02J-472X	MG R	4.7kΩ 1/10W J
R1309	NRSA02J-103X	MG R	10kΩ 1/10W J
R1311	NRSA02J-273X	MG R	27kΩ 1/10W J
R1312	NRSA02J-0ROX	MG R	0.0Ω 1/10W J
R1314	NRSA02J-0ROX	MG R	0.0Ω 1/10W J
R1341	NRSA02J-121X	MG R	120Ω 1/10W J
R1342-43	NRSA02J-333X	MG R	33kΩ 1/10W J
R1351-53	NRSA02J-151X	MG R	150Ω 1/10W J
R1354-56	NRSA02J-331X	MG R	330Ω 1/10W J
R1357-59	NRSA02J-101X	MG R	100Ω 1/10W J
R1360-62	QRZ0107-152Z	C R	1.5kΩ 1/2W K
R1363-65	QRL029J-123	OM R	12kΩ 2W J
R1366-68	NRSA02J-272X	MG R	2.7kΩ 1/10W J
R1401	NRSA02J-103X	MG R	10kΩ 1/10W J
R1402	NRSA02J-682X	MG R	6.8kΩ 1/10W J
R1403	NRSA02J-0ROX	MG R	0.0Ω 1/10W J
R1404	NRSA02J-102X	MG R	1kΩ 1/10W J
R1405	NRSA02J-221X	MG R	220Ω 1/10W J
R1406-08	NRSA02J-472X	MG R	4.7kΩ 1/10W J
R1410	NRSA02J-0ROX	MG R	0.0Ω 1/10W J
R1413	QRE121J-391Y	C R	390Ω 1/2W J

Symbol No.	Part No.	Part Name	Description
RESISTOR			
R1414	QRX016J-1R2	MF R	1.2Ω 1W J
R1416	NRSA02J-563X	MG R	56kΩ 1/10W J
R1418	NRSA02J-563X	MG R	56kΩ 1/10W J
R1419	NRSA02J-223X	MG R	22kΩ 1/10W J
R1421-22	NRSA02J-0ROX	MG R	0.0Ω 1/10W J
R1423	NRSA02J-103X	MG R	10kΩ 1/10W J
R1501	NRSA02J-0ROX	MG R	0.0Ω 1/10W J
R1503	NRSA02J-103X	MG R	10kΩ 1/10W J
R1504	NRSA02J-104X	MG R	100kΩ 1/10W J
R1505	NRSA02J-822X	MG R	8.2kΩ 1/10W J
R1506	NRSA02J-102X	MG R	1kΩ 1/10W J
R1510	NRSA02J-0ROX	MG R	0.0Ω 1/10W J
R1512	NRSA02J-103X	MG R	10kΩ 1/10W J
R1513	NRSA02J-0ROX	MG R	0.0Ω 1/10W J
R1514	NRSA02J-333X	MG R	33kΩ 1/10W J
R1521	QRL039J-562	OM R	5.6kΩ 3W J
R1523	NRSA02J-222X	MG R	2.2kΩ 1/10W J
R1524	QRE121J-103Y	C R	10kΩ 1/2W J
R1526	QRL029J-152	OM R	1.5kΩ 2W J
R1529	NRSA02J-621X	MG R	620Ω 1/10W J
R1532	QRL039J-472	OM R	4.7kΩ 3W J
R1533	QRE121J-220Y	C R	22Ω 1/2W J
R1543	QRT039J-R47	MF R	0.47Ω 3W J
R1544	QRL039J-223	OM R	22kΩ 3W J
△ R1562	QRA14CF-6801Y	MF R	6.8kΩ 1/4W F
△ R1563	QRA14CF-3741Y	MF R	3.74kΩ 1/4W F
R1581	QRE121J-273Y	C R	27kΩ 1/2W J
R1582	QRE121J-393Y	C R	39kΩ 1/2W J
R1584	QRE121J-223Y	C R	22kΩ 1/2W J
R1603	NRSA02J-682X	MG R	6.8kΩ 1/10W J
R1605	NRSA02J-391X	MG R	390Ω 1/10W J
R1607	NRSA02J-682X	MG R	6.8kΩ 1/10W J
R1609	NRSA02J-391X	MG R	390Ω 1/10W J
R1611	NRSA02J-223X	MG R	22kΩ 1/10W J
R1613	NRSA02J-333X	MG R	33kΩ 1/10W J
R1620	NRSA02J-183X	MG R	18kΩ 1/10W J
R1622	NRSA02J-183X	MG R	18kΩ 1/10W J
R1626	NRSA02J-153X	MG R	15kΩ 1/10W J
R1627	NRSA02J-104X	MG R	100kΩ 1/10W J
R1628	NRSA02J-153X	MG R	15kΩ 1/10W J
R1629	NRSA02J-104X	MG R	100kΩ 1/10W J
R1631	NRSA02J-473X	MG R	47kΩ 1/10W J
R1635-36	QRE121J-271Y	C R	270Ω 1/2W J
R1651	NRSA02J-102X	MG R	1kΩ 1/10W J
R1652	NRSA02J-392X	MG R	3.9kΩ 1/10W J
R1653	NRSA02J-152X	MG R	1.5kΩ 1/10W J
R1654	NRSA02J-333X	MG R	33kΩ 1/10W J
R1655	NRSA02J-332X	MG R	3.3kΩ 1/10W J
R1656	NRVA02D-152X	MF R	1.5kΩ 1/10W D
R1658	NRVA02D-153X	MF R	15kΩ 1/10W D
R1660	NRSA02J-512X	MG R	5.1kΩ 1/10W J
R1669-70	NRSA02J-471X	MG R	470Ω 1/10W J
R1671	NRSA02J-102X	MG R	1kΩ 1/10W J
R1672	NRSA02J-102X	MG R	1kΩ 1/10W J
R1673-74	NRSA02J-823X	MG R	82kΩ 1/10W J
R1675-76	NRSA02J-181X	MG R	180Ω 1/10W J
R1677	NRSA02J-103X	MG R	10kΩ 1/10W J
R1678	NRSA02J-223X	MG R	22kΩ 1/10W J
R1679	NRSA02J-223X	MG R	22kΩ 1/10W J
R1680	NRSA02J-223X	MG R	22kΩ 1/10W J
R1681	NRSA02J-223X	MG R	22kΩ 1/10W J
R1682	NRSA02J-683X	MG R	68kΩ 1/10W J
R1685	NRSA02J-102X	MG R	1kΩ 1/10W J
R1686	NRSA02J-102X	MG R	1kΩ 1/10W J
R1687	NRSA02J-102X	MG R	1kΩ 1/10W J
R1688	NRSA02J-102X	MG R	1kΩ 1/10W J
R1691	NRSA02J-102X	MG R	1kΩ 1/10W J
R1692	NRSA02J-102X	MG R	1kΩ 1/10W J

△ Symbol No.	Part No.	Part Name	Description
RESISTOR			
R1701	NRSA02J-563X	MG R	56kΩ 1/10W J
R1702	NRSA02J-223X	MG R	22kΩ 1/10W J
R1703	NRSA02J-0ROX	MG R	0.0Ω 1/10W J
R1704	NRSA02J-103X	MG R	10kΩ 1/10W J
R1705	NRSA02J-102X	MG R	1kΩ 1/10W J
R1706	NRSA02J-823X	MG R	82kΩ 1/10W J
R1707	NRSA02J-103X	MG R	10kΩ 1/10W J
R1708	NRSA02J-0ROX	MG R	0.0Ω 1/10W J
R1709	NRSA02J-103X	MG R	10kΩ 1/10W J
R1710	NRSA02J-102X	MG R	1kΩ 1/10W J
R1711	NRSA02J-103X	MG R	10kΩ 1/10W J
R1712	NRSA02J-0ROX	MG R	0.0Ω 1/10W J
R1713	NRSA02J-103X	MG R	10kΩ 1/10W J
R1714	NRSA02J-0ROX	MG R	0.0Ω 1/10W J
R1715	NRSA02J-472X	MG R	4.7kΩ 1/10W J
R1716	NRSA02J-0ROX	MG R	0.0Ω 1/10W J
R1717	NRSA02J-472X	MG R	4.7kΩ 1/10W J
R1718	NRSA02J-0ROX	MG R	0.0Ω 1/10W J
R1719	NRSA02J-473X	MG R	47kΩ 1/10W J
R1720	NRSA02J-683X	MG R	68kΩ 1/10W J
R1721	NRSA02J-473X	MG R	47kΩ 1/10W J
R1725	NRSA02J-102X	MG R	1kΩ 1/10W J
R1726	NRSA02J-0ROX	MG R	0.0Ω 1/10W J
R1727	NRSA02J-103X	MG R	10kΩ 1/10W J
R1728	NRSA02J-102X	MG R	1kΩ 1/10W J
R1729	NRSA02J-105X	MG R	1MΩ 1/10W J
R1732	NRSA02J-102X	MG R	1kΩ 1/10W J
R1733	NRSA02J-333X	MG R	33kΩ 1/10W J
R1734	NRSA02J-102X	MG R	1kΩ 1/10W J
R1735	NRSA02J-102X	MG R	1kΩ 1/10W J
R1736	NRSA02J-124X	MG R	120kΩ 1/10W J
R1737	NRSA02J-184X	MG R	180kΩ 1/10W J
R1738	NRSA02J-102X	MG R	1kΩ 1/10W J
R1739	NRSA02J-102X	MG R	1kΩ 1/10W J
R1740	NRSA02J-472X	MG R	4.7kΩ 1/10W J
R1741	NRSA02J-102X	MG R	1kΩ 1/10W J
R1742	NRSA02J-472X	MG R	4.7kΩ 1/10W J
R1743	NRSA02J-223X	MG R	22kΩ 1/10W J
R1744	NRSA02J-103X	MG R	10kΩ 1/10W J
R1745	NRSA02J-153X	MG R	15kΩ 1/10W J
R1746	NRSA02J-103X	MG R	10kΩ 1/10W J
R1747	NRSA02J-153X	MG R	15kΩ 1/10W J
R1748	NRSA02J-103X	MG R	10kΩ 1/10W J
R1749	NRSA02J-153X	MG R	15kΩ 1/10W J
R1750-51	NRSA02J-561X	MG R	560Ω 1/10W J
R1752-53	NRSA02J-103X	MG R	10kΩ 1/10W J
R1754	NRSA02J-562X	MG R	5.6kΩ 1/10W J
R1755-56	NRSA02J-103X	MG R	10kΩ 1/10W J
R1757	NRSA02J-562X	MG R	5.6kΩ 1/10W J
R1758	NRSA02J-223X	MG R	22kΩ 1/10W J
R1759	NRSA02J-103X	MG R	10kΩ 1/10W J
R1765	NRSA02J-122X	MG R	1.2kΩ 1/10W J
R1766	NRSA02J-102X	MG R	1kΩ 1/10W J
R1771-72	NRSA02J-221X	MG R	220Ω 1/10W J
R1781-82	NRSA02J-681X	MG R	680Ω 1/10W J
R1783-84	NRSA02J-221X	MG R	220Ω 1/10W J
R1801-03	NRSA02J-221X	MG R	220Ω 1/10W J
R1811-13	NRSA02J-0ROX	MG R	0.0Ω 1/10W J
R1815	NRSA02J-0ROX	MG R	0.0Ω 1/10W J
R1816	NRSA02J-103X	MG R	10kΩ 1/10W J
△ R1901	QRF104K-3R9	UMF R	3.9Ω 10W K
R1902	QRL039J-393	OM R	39kΩ 3W J
R1910	QRE121J-564Y	C R	560kΩ 1/2W J
R1911	QRE121J-183Y	C R	18kΩ 1/2W J
R1921	QRE121J-681Y	C R	680Ω 1/2W J
R1922	QRMO59J-R22	MP R	0.22Ω 5W J
R1923	QRT029J-R39	MF R	0.39Ω 2W J
R1924	QRE121J-103Y	C R	10kΩ 1/2W J
R1925	QRE121J-102Y	C R	1kΩ 1/2W J
R1926	QRE121J-152Y	C R	1.5kΩ 1/2W J
R1929	QRE121J-332Y	C R	3.3kΩ 1/2W J

△ Symbol No.	Part No.	Part Name	Description
RESISTOR			
R1932	QRE121J-4R7Y	C R	4.7Ω 1/2W J
R1942	NRSA02J-223X	MG R	22kΩ 1/10W J
R1943	QRE121J-152Y	C R	1.5kΩ 1/2W J
R1944	NRSA02J-103X	MG R	10kΩ 1/10W J
R1945	NRSA02J-332X	MG R	3.3kΩ 1/10W J
R1946	NRSA02J-123X	MG R	12kΩ 1/10W J
R1947	QRE121J-470Y	C R	47Ω 1/2W J
R1948	NRSA02J-152X	MG R	1.5kΩ 1/10W J
R1949	NRSA02J-153X	MG R	15kΩ 1/10W J
R1950	NRSA02J-103X	MG R	10kΩ 1/10W J
R1951	NRSA02J-332X	MG R	3.3kΩ 1/10W J
R1952	NRSA02J-472X	MG R	4.7kΩ 1/10W J
R1959	NRSA02J-0ROX	MG R	0.0Ω 1/10W J
R1961-62	QRT029J-1R8	MF R	1.8Ω 2W J
R1964	QRE121J-272Y	C R	2.7kΩ 1/2W J
R1965	QRE121J-473Y	C R	47kΩ 1/2W J
R1966	NRSA02J-223X	MG R	22kΩ 1/10W J
R1967	QRG01GJ-681	OM R	680Ω 1W J
△ R1981	QRZ0057-825	C R	8.2MΩ 1W J

CAPACITOR

C1001	QETN1HM-106Z	E CAP.	10μF 50V M
C1007	QETN1CM-477Z	E CAP.	470μF 16V M
C1008-09	QETN1CM-107Z	E CAP.	100μF 16V M
C1011	NCB21HK-103X	C CAP.	0.01μF 50V K
C1101-02	NCB21HK-103X	C CAP.	0.01μF 50V K
C1103	NDC21HJ-680X	C CAP.	68pF 50V J
C1104-05	NCB21HK-103X	C CAP.	0.01μF 50V K
C1111	QETN1EM-476Z	E CAP.	47μF 25V M
C1112-14	NCB21HK-103X	C CAP.	0.01μF 50V K
C1116	QFV71HJ-224Z	MF CAP.	0.22μF 50V J
C1117	QETN1EM-476Z	E CAP.	47μF 25V M
C1118	NCB21HK-103X	C CAP.	0.01μF 50V K
C1119	NDC21HJ-681X	C CAP.	680pF 50V J
C1120	QETN1HM-225Z	E CAP.	2.2μF 50V M
C1123-24	NCB21HK-103X	C CAP.	0.01μF 50V K
C1161	QETN1HM-106Z	E CAP.	10μF 50V M
C1163-64	NDC21HJ-470X	C CAP.	47pF 50V J
C1165-66	NCB21HK-103X	C CAP.	0.01μF 50V K
C1202	QETN1CM-107Z	E CAP.	100μF 16V M
C1207	NCB21HK-104X	CHIP CAP.	0.1μF 50V K
C1208	QETN1HM-475Z	E CAP.	4.7μF 50V M
C1209	QETN1CM-227Z	E CAP.	220μF 16V M
C1210	NCB21HK-103X	C CAP.	0.01μF 50V K
C1211	NDC21HJ-681X	C CAP.	680pF 50V J
C1212	NCB21HK-104X	CHIP CAP.	0.1μF 50V K
C1213	QETN1HM-105Z	E CAP.	1μF 50V M
C1214	NCB21HK-104X	CHIP CAP.	0.1μF 50V K
C1215	QETN1HM-106Z	E CAP.	10μF 50V M
C1251	QENC1HM-106Z	BP E CAP.	10μF 50V M
C1252	QETN1HM-106Z	E CAP.	10μF 50V M
C1254	QETN1CM-477Z	E CAP.	470μF 16V M
C1255	QETN1HM-106Z	E CAP.	10μF 50V M
C1256	QETN1CM-227Z	E CAP.	220μF 16V M
C1291-92	QETN1CM-107Z	E CAP.	100μF 16V M
C1294	QETN1CM-107Z	E CAP.	100μF 16V M
C1296	QETN1CM-107Z	E CAP.	100μF 16V M
C1301-02	NDC21HJ-150X	C CAP.	15pF 50V J
C1303	NDC21HJ-120X	C CAP.	12pF 50V J
C1304	NCB21HK-103X	C CAP.	0.01μF 50V K
C1305	NDC21HJ-120X	C CAP.	12pF 50V J
C1306	QETN1EM-476Z	E CAP.	47μF 25V M
C1307	NCB21HK-103X	C CAP.	0.01μF 50V K
C1308-09	NCB21HK-104X	CHIP CAP.	0.1μF 50V K
C1311	QFV71HJ-334Z	MF CAP.	0.33μF 50V J
C1312	NCB21HK-103X	C CAP.	0.01μF 50V K
C1313	QETN1HM-475Z	E CAP.	4.7μF 50V M
C1342	QETN1HM-335Z	E CAP.	3.3μF 50V M
C1354-55	NDC21HJ-271X	C CAP.	270pF 50V J
C1356	NDC21HJ-331X	C CAP.	330pF 50V J

△ Symbol No.	Part No.	Part Name	Description
CAPACITOR			
△ C1357	QETN1CM-107Z	E CAP.	100µF 16V M
C1382	QCZ0121-102	C CAP.	1000pF 3kV Z
C1401-02	QETN1HM-105Z	E CAP.	1µF 50V M
C1403	QEM61EK-225Z	E CAP.	2.2µF 25V K
C1405	QFV71HJ-104Z	MF CAP.	0.1µF 50V J
C1406	QFN31HJ-472Z	M CAP.	4700pF 50V J
C1410	QETN1VM-107Z	E CAP.	100µF 35V M
C1411	QETN1VM-477Z	E CAP.	470µF 35V M
C1412	QFLB2AK-154	M CAP.	0.15µF 100V K
C1413	QETN1EM-108Z	E CAP.	1000µF 25V M
C1414	QETN1HM-105Z	E CAP.	1µF 50V M
C1415	QFN31HJ-152Z	M CAP.	1500pF 50V J
C1416	NDC21HJ-681X	C CAP.	680pF 50V J
C1501	QETN1CM-107Z	E CAP.	100µF 16V M
C1503	NCB21HK-103X	C CAP.	0.01µF 50V K
C1505-06	NCB21HK-103X	C CAP.	0.01µF 50V K
C1507	QETN1HM-105Z	E CAP.	1µF 50V M
C1511	QETN1HM-106Z	E CAP.	10µF 50V M
C1521	QCB32HK-151Z	C CAP.	150pF 500V K
C1522	QCB32HK-331Z	C CAP.	330pF 500V K
C1523	QETN2CM-105Z	E CAP.	1µF 160V M
△ C1524	QFZ0198-782	MPP CAP.	7800pF 1.5kVH ±3%
△ C1525	QFZ0119-434	MPP CAP.	0.43µF 200V ±3%
△ C1526	QEZO203-476	E CAP.	47µF 160V M
C1541	QETN2EM-106Z	E CAP.	10µF 250V M
C1543	QETN1VM-477Z	E CAP.	470µF 35V M
C1546-47	QETN1CM-227Z	E CAP.	220µF 16V M
C1561	QETN1VM-107Z	E CAP.	100µF 35V M
C1581	QFLC1HJ-473Z	M CAP.	0.047µF 50V J
C1583	QFV71HJ-104Z	MF CAP.	0.1µF 50V J
C1584	QFLC2AJ-103Z	M CAP.	0.01µF 100V J
C1603	NRSA02J-OROX	MG R	0.0Ω 1/10W J
C1604	QENC1HM-474Z	BP E CAP.	0.47µF 50V M
C1606	NRSA02J-OROX	MG R	0.0Ω 1/10W J
C1607	QENC1HM-474Z	BP E CAP.	0.47µF 50V M
C1609	QETN1CM-107Z	E CAP.	100µF 16V M
C1613	QETN1CM-108Z	E CAP.	1000µF 16V M
C1615	QETN1CM-477Z	E CAP.	470µF 16V M
C1617	QETN1CM-477Z	E CAP.	470µF 16V M
C1622	QETN1HM-105Z	E CAP.	1µF 50V M
C1623-24	QENC1HM-474Z	BP E CAP.	0.47µF 50V M
C1631	QETN1EM-477Z	E CAP.	470µF 25V M
C1637-38	NCB21HK-332X	C CAP.	3300pF 50V K
C1651	NCB21HK-103X	C CAP.	0.01µF 50V K
C1652	QETN1CM-107Z	E CAP.	100µF 16V M
C1653	QETN1EM-476Z	E CAP.	47µF 25V M
C1654	NCB21HK-104X	CHIP CAP.	0.1µF 50V K
C1655	QENC1HM-475Z	BP E CAP.	4.7µF 50V M
C1656	QENC1HM-105Z	BP E CAP.	1µF 50V M
C1657	QETN1HM-225Z	E CAP.	2.2µF 50V M
C1658	NCB21HK-473X	C CAP.	0.047µF 50V K
C1659	QETN1HM-474Z	E CAP.	0.47µF 50V M
C1660-61	NCB21HK-104X	CHIP CAP.	0.1µF 50V K
C1662	QBTC1CK-335Z	TAN. CAP.	3.3µF 16V K
C1663	QETN1HM-105Z	E CAP.	1µF 50V M
C1664	QBTC1CK-106Z	TAN. CAP.	10µF 16V K
C1665-66	QETN1HM-105Z	E CAP.	1µF 50V M
C1667	QETN1HM-336Z	E CAP.	33µF 50V M
C1668	QETN1HM-105Z	E CAP.	1µF 50V M
C1671	QETN1HM-225Z	E CAP.	2.2µF 50V M
C1672	NCB21HK-222X	C CAP.	2200pF 50V K
C1673	NCB21HK-104X	CHIP CAP.	0.1µF 50V K
C1674	QETN1HM-225Z	E CAP.	2.2µF 50V M
C1675	NCB21HK-222X	C CAP.	2200pF 50V K
C1676	NCB21HK-104X	CHIP CAP.	0.1µF 50V K
C1677	NCB21HK-223X	C CAP.	0.022µF 50V K
C1679	QETN1HM-105Z	E CAP.	1µF 50V M
C1682-83	QETN1HM-475Z	E CAP.	4.7µF 50V M
C1684-86	QETN1HM-106Z	E CAP.	10µF 50V M
C1691-92	QETN1HM-106Z	E CAP.	10µF 50V M
C1693-94	NCB21HK-332X	C CAP.	3300pF 50V K
C1701	NRSA02J-OROX	MG R	0.0Ω 1/10W J

△ Symbol No.	Part No.	Part Name	Description
CAPACITOR			
C1703	NRSA02J-OROX	MG R	0.0Ω 1/10W J
C1704	NCB21HK-102X	C CAP.	1000pF 50V K
C1706	QETN1AM-227Z	E CAP.	220µF 10V M
C1707	NCB21HK-103X	C CAP.	0.01µF 50V K
C1708	QETN1HM-106Z	E CAP.	10µF 50V M
C1711	NDC21HJ-151X	C CAP.	150pF 50V J
C1712	NCB21HK-104X	CHIP CAP.	0.1µF 50V K
C1713	QETN1HM-105Z	E CAP.	1µF 50V M
C1714	NDC21HJ-221X	C CAP.	220pF 50V J
C1715	NCB21HK-102X	C CAP.	1000pF 50V K
C1716	QENC1HM-474Z	BP E CAP.	0.47µF 50V M
C1717	NDC21HJ-180X	C CAP.	180pF 50V J
C1718	NDC21HJ-220X	C CAP.	22pF 50V J
C1719	QETN1CM-107Z	E CAP.	100µF 16V M
C1720	NCB21HK-104X	CHIP CAP.	0.1µF 50V K
C1723	NDC21HJ-151X	C CAP.	150pF 50V J
C1724	QETN1HM-105Z	E CAP.	1µF 50V M
C1725	NDC21HJ-151X	C CAP.	150pF 50V J
C1727	NCB21HK-103X	C CAP.	0.01µF 50V K
C1733	QETN1EM-476Z	E CAP.	47µF 25V M
C1734	NCB21HK-104X	CHIP CAP.	0.1µF 50V K
C1735	NCB21HK-103X	C CAP.	0.01µF 50V K
C1736	QETN1CM-107Z	E CAP.	100µF 16V M
C1738	QETN1EM-476Z	E CAP.	47µF 25V M
C1742	QETN1HM-225Z	E CAP.	2.2µF 50V M
C1765	NDC21HJ-101X	C CAP.	100pF 50V J
C1771	QETN1EM-476Z	E CAP.	47µF 25V M
C1772	NCB21HK-103X	C CAP.	0.01µF 50V K
C1805	QETN1CM-227Z	E CAP.	220µF 16V M
C1806	NCB21HK-103X	C CAP.	0.01µF 50V K
C1811-13	NCB21HK-103X	C CAP.	0.01µF 50V K
△ C1901	QFZ9040-104	MF CAP.	0.1µF AC275V M
△ C1902	QFZ9040-104	MF CAP.	0.1µF AC275V M
△ C1903	QCZ9078-472	C CAP.	4700pFAC250V M
△ C1904	QCZ9078-472	C CAP.	4700pFAC250V M
△ C1905	QCZ9078-472	C CAP.	4700pFAC250V M
△ C1906	QEZO199-127	E CAP.	120µF 400V M
C1921	QCZ0325-102	C CAP.	1000pF 2kV K
C1922	QCS31HJ-471Z	C CAP.	470pF 50V J
C1924	QETN1VM-107Z	E CAP.	100µF 35V M
C1925	QFN31HJ-102Z	M CAP.	1000pF 50V J
C1926	QFN31HJ-182Z	M CAP.	1800pF 50V J
C1928	QFV71HJ-104Z	MF CAP.	0.1µF 50V J
C1931	QCZ0122-391	C CAP.	390pF 2kV K
C1941	QCZ0122-471	C CAP.	470pF 2kV K
△ C1942	QEZO203-107	E CAP.	100µF 160V M
C1943	QCB32HK-471Z	C CAP.	470pF 500V K
C1944	QETN1EM-108Z	E CAP.	1000µF 25V M
C1945	QETN1EM-227Z	E CAP.	220µF 25V M
C1946	QETN1EM-107Z	E CAP.	100µF 25V M
C1947	QETN1HM-106Z	E CAP.	10µF 50V M
C1952	QETN1EM-108Z	E CAP.	1000µF 25V M
C1953	QCZ0122-471	C CAP.	470pF 2kV K
C1957	NDC21HJ-471X	C CAP.	470pF 50V J
C1961	QETN1CM-107Z	E CAP.	100µF 16V M
C1962	QETN1EM-476Z	E CAP.	47µF 25V M
△ C1981	QCZ9079-471	C CAP.	470pFAC250V K
△ C1982	QCZ9079-102	C CAP.	1000pFAC250V M
△ C1983	QCZ9079-471	C CAP.	470pFAC250V K
C1984	QETN1VM-337Z	E CAP.	330µF 35V M
TRANSFORMER			
T1111	CELT001-209J3	C. WAVE TRANSF.	
T1521	CE42034-001	H. DRIVE TRANSF.	
△ T1522	QQH0030-002	H. V. TRANSF.	
△ T1921	CETS109-001JK	SWITCH. TRANSF.	
COIL			
L1001	QLL03BJ-150Z	COIL	15µH J
L1003	QLL03BJ-4R7Z	COIL	4.7µH J
L1101	QLL2014-R22	PEAKING COIL	
L1131	QLL03BJ-150Z	COIL	15µH J

△ Symbol No.	Part No.	Part Name	Description
COIL			
L1161	QQL03BJ-220Z	COIL	22μH J
L1205	QQL03BJ-4R7Z	COIL	4.7μH J
L1301	QQL03BJ-390Z	COIL	39μH J
L1381	QQL03BJ-390Z	COIL	39μH J
L1501	QQL03BJ-4R7Z	COIL	4.7μH J
L1701-02	QQL03BJ-4R7Z	COIL	4.7μH J
L1708	QQL03BJ-560Z	COIL	56μH J
L1771	QQL03BJ-4R7Z	COIL	4.7μH J
L1941-42	QQL26AK-820Z	COIL	82μH K
DIODE			
D1001	MTZ133A-T2	ZENER DIODE	
D1201	1S5133-T2	SI. DIODE	
D1202	MTZ17.5B-T2	ZENER DIODE	
D1251	MTZ19.1C-T2	ZENER DIODE	
D1253-56	MTZ15.6A-T2	ZENER DIODE	
D1257	MTZ19.1C-T2	ZENER DIODE	
D1341	1S5133-T2	SI. DIODE	
D1401	1N4003-T2	SI. DIODE	
D1402	MTZ175-T2	ZENER DIODE	
D1510	1S5133-T2	SI. DIODE	
D1541	RH15-T3	SI. DIODE	
D1542	RGP10J-5025-T3	SI. DIODE	
D1543	RGP10J-5025-T3	SI. DIODE	
D1544	RH15-T3	SI. DIODE	
D1561	1S581-T2	SI. DIODE	
△ D1562	MTZ17.5S-T2	ZENER DIODE	
D1581	RGP10J-5025-T3	SI. DIODE	
D1582	MTZ19.1B-T2	ZENER DIODE	
D1631	1S5133-T2	SI. DIODE	
D1632	1S5133-T2	SI. DIODE	
D1633	1S5133-T2	SI. DIODE	
D1634	1S5133-T2	SI. DIODE	
D1656-57	MTZ19.1C-T2	ZENER DIODE	
D1691-92	MTZ19.1C-T2	ZENER DIODE	
D1701	1S5133-T2	SI. DIODE	
D1702	1S5133-T2	SI. DIODE	
D1704	1S5133-T2	SI. DIODE	
D1705	MTZ15.6A-T2	ZENER DIODE	
D1706	SLR-342VR-T16	L. E. D.	
D1707	SLR-342DU-T16	L. E. D. (ORG)	
D1771-72	MTZ16.2B-T2	ZENER DIODE	
D1801-03	MTZ115B-T2	ZENER DIODE	
△ D1805	MTZ115B-T2	ZENER DIODE	
D1901	D2SBA60	BRIDGE DIODE	
D1903	RGP10J-5025-T3	SI. DIODE	
D1905	MTZ16.8A-T2	ZENER DIODE	
D1921	RGP10J-5025-T3	SI. DIODE	
D1922	RGP10J-5025-T3	SI. DIODE	
D1923	MTZ115A-T2	ZENER DIODE	
D1924	1S5133-T2	SI. DIODE	
D1927	1S5133-T2	SI. DIODE	
D1928	1S5133-T2	SI. DIODE	
D1929	MTZ115A-T2	ZENER DIODE	
D1941	RU3AM-LFC4	SI. DIODE	
D1942	RGP10J-5025-T3	SI. DIODE	
D1943	1S5133-T2	SI. DIODE	
D1945	MTZ15.6B-T2	ZENER DIODE	
D1948	RGP10J-5025-T3	SI. DIODE	
D1961	MTZ17.5S-T2	ZENER DIODE	
D1962	1S5133-T2	SI. DIODE	
TRANSISTOR			
Q1101	2SC5083/L-P/-T	SI. TRANSISTOR	
Q1111	DTC124EKA-X	DIGI. TRANSISTOR	
Q1131	2SC2412K/QR/-X	SI. TRANSISTOR	
Q1161	2SC2412K/QR/-X	SI. TRANSISTOR	
Q1201-02	2SC2412K/QR/-X	SI. TRANSISTOR	
Q1251	2SC1740S/QR/-T	SI. TRANSISTOR	
Q1301-02	2SC2412K/QR/-X	SI. TRANSISTOR	
Q1341-42	2SC2412K/QR/-X	SI. TRANSISTOR	
Q1351-53	2SC4544-LB	SI. TRANSISTOR	
Q1401	2SC2412K/QR/-X	SI. TRANSISTOR	
Q1511	2SC2785/JH/-T	SI. TRANSISTOR	
Q1521	BSN304-T	F. E. T.	

△ Symbol No.	Part No.	Part Name	Description
TRANSISTOR			
△ Q1522	2SD1878-YD	SI. TRANSISTOR	H. OUT
Q1601	2SC2412K/QR/-X	SI. TRANSISTOR	
Q1603-05	DTC323TK-X	DIGI. TRANSISTOR	
Q1631	2SA1037AK/QR/-X	SI. TRANSISTOR	
Q1651-54	DTC323TK-X	DIGI. TRANSISTOR	
Q1701-02	2SC2412K/QR/-X	SI. TRANSISTOR	
Q1703	DTC124EKA-X	DIGI. TRANSISTOR	
Q1705	DTC124EKA-X	DIGI. TRANSISTOR	
Q1761	2SC2412K/QR/-X	SI. TRANSISTOR	
Q1921	2SA933AS/QR/-T	SI. TRANSISTOR	
Q1941	2SA966/OY/-T	SI. TRANSISTOR	
Q1942-44	2SC2412K/QR/-X	SI. TRANSISTOR	
Q1961	2SA949/Y/Z1-T	SI. TRANSISTOR	
IC			
IC1001	AN78L05-T	I. C. (MONO-ANA)	
IC1101	MS2342SP	I. C. (MONO-ANA)	
IC1201	TB1230AN	I. C. (DIGI-OTHER)	
IC1251	BA7612N	I. C. (MONO-ANA)	
IC1291	AN78N05	I. C. (M)	
IC1292	AN78L09-T	I. C. (MONO-ANA)	
IC1293	KIA78L05BP-T	I. C. (MONO-ANA)	
△ IC1401	LA7840	I. C. (MONO-ANA)	
IC1541	AN7809F	I. C. (MONO-ANA)	
△ IC1601	LA4485	I. C. (MONO-ANA)	
IC1651	UPC1851BCU	I. C. (MONO-ANA)	
IC1701	M37272MA-320SP	I. C. (MICRO-COMP)	
IC1702	L78L05E-MA	I. C. (MONO-ANA)	
IC1703	GP1U281Q	IFR DETECT UNIT	
IC1704	AT24C02T2122AR	I. C.	(SERVICE)
△ IC1921	STR-F6654	I. C. (HYBRID)	
△ IC1941	SE135N	I. C. (HYBRID)	
OTHERS			
CF1001	LC30114-001C-H	L. E. D. HOLDER	
CF1131	FTP47.25MF	CERAMIC FILTER	
CF1161	QAX0339-001	CERAMIC FILTER	
CF1941	SFSH4.5MCB	CERAMIC FILTER	
△ CP1941	ICP-N75-Y	I. C. PROTECT	
△ CP1942	ICP-N50-Y	I. C. PROTECT	
EF1301	CE42142-222Z	EMI FILTER	
△ F1901	QMF51E2-3R15J4	FUSE	3.15A
△ FC1901	CEMG002-001Z	FUSE CLIP	
△ FC1902	CEMG002-001Z	FUSE CLIP	
△ FR1542	QRZ9023-1R0	F R	1.0 Ω 2W J
△ FR1561	QRZ9017-4R7	F R	4.7 Ω 1/4W J
△ FR1585	QRZ9021-1R5	F R	1.5 Ω 1W J
△ FR1586	QRE121J-332Y	C R	3.3kΩ 1/2W J
△ FR1621	QRZ9023-1R5	F R	1.5 Ω 2W J
△ FR1720	QRZ9017-270	F R	27 Ω 1/4W J
J1001-02	QNN0349-001	PIN JACK	
J1003	CEMN065-001	PIN JACK	
J1004	CEMN065-002	PIN JACK	
J1005	CEMN072-003	PIN JACK	
J1006	QNS0155-001	JACK	
K1401	QQR0621-001Z	BEADS CORE	
K1921	QQR0621-001Z	BEADS CORE	
K1923	QQR0582-001Z	BEADS CORE	
K1941	QQR0621-001Z	BEADS CORE	
K1942	QQR0582-001Z	BEADS CORE	
K1943	QQR0621-001Z	BEADS CORE	
△ LF1901	QQR0673-002	LINE FILTER	
△ PC1921	TLP621 (GR)-LF2	I. C. (PH. COUPLER)	
S1701	QSW0619-003Z	PUSH SWITCH	VOL+
S1702	QSW0619-003Z	PUSH SWITCH	VOL-
S1703	QSW0619-003Z	PUSH SWITCH	CH+
S1704	QSW0619-003Z	PUSH SWITCH	CH-
S1705	QSW0619-003Z	PUSH SWITCH	MENU
△ S1901	OSP4K21-C01	PUSH SWITCH	POWER
SF1101	QAX0324-002	SAW FILTER	
△ SK1351	CE42535-001J1	C. R. T. SOCKET	
△ TH1901	QAD0101-9R0	P. THERMISTOR	
TU1001	QAU0069-001	TUNER	
△ VA1901	ERZV10V621CS	VARIATOR	
X1301	QAX0305-001Z	CRYSTAL	
X1701	QAX0468-001Z	CRYSTAL	

PACKING

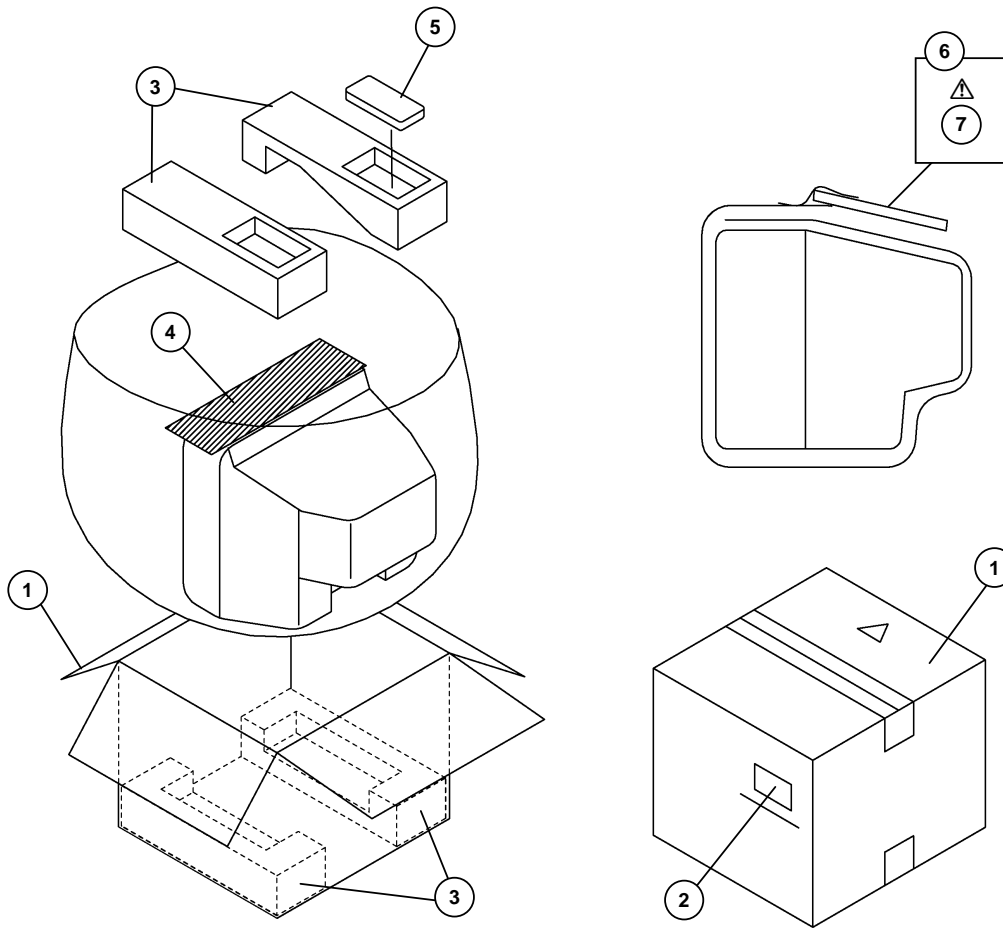

PACKING PARTS LIST

△ Ref.No.	Part No.	Part Name	Description
1	CP11432-009-R	PACKING CASE	
2	CM36242-011-R	POS LABEL	
3	LC10516-008A-D	CUSHION ASSY	4pcs in 1set
4	CP30899-001-R	TOP COVER	
6	CP30897-002-R	POLY BAG	
5	RM-C373-1H	REMOCON UNIT	
6	CP30897-001-R	POLY BAG	
△ 7	LCT1040-001A-D	INST BOOK	

REMOTE CONTROL UNIT PARTS LIST (RM-C373-1H)

△ Ref.No.	Part No.	Part Name	Description
--	25-1168B	BATTERY COVER	



JVC

VICTOR COMPANY OF JAPAN, LIMITED
HOME AV NETWORK BUSINESS UNIT 12, 3-chome, Moriya-cho, Kanagawa-ku, Yokohama, Kanagawa-prefecture, 221-8528, Japan

AVT2122AR-CK #3



Printed in Japan
VP 0109
DP7051

Other ManualsLib Projects



www.manualslib.com



www.manualslib.de



www.manualslib.es



www.manualslib.fr



www.manualslib.nl



www.manualslib.mx



www.manualslib.tech 30+ Languages